

TECHNICAL MANUAL

**OPERATOR'S ORGANIZATIONAL, DIRECT SUPPORT
AND GENERAL SUPPORT MAINTENANCE MANUAL
FOR
GRINDING MACHINE
MODEL B2062
(NSN 3415-01-060-8594)
K.O. LEE COMPANY**

HEADQUARTERS, DEPARTMENT OF THE ARMY

AUGUST 1981

Technical Manual }
No. 9-3415-236-14 }

HEADQUARTERS
DEPARTMENT OF THE ARMY
Washington, DC, 15 August 1981

**OPERATOR'S, ORGANIZATIONAL, DIRECT SUPPORT
AND GENERAL SUPPORT MAINTENANCE MANUAL
FOR
GRINDING MACHINE**

REPORTING ERRORS AND RECOMMENDING IMPROVEMENTS

You can help improve this manual. If you find any mistakes or if you know of a way to improve the procedures, please let us know. Mail your letter, DA Form 2028 (Recommended Changes to Publications and Blank Forms), or DA Form 2028-2, located in the back of this manual direct to: Commander, US Army Armament Materiel Readiness Command, ATTN: DRSAR-MAS, Rock Island, IL 61299. A reply will be furnished direct to you.

NOTE

This manual is published for the purpose of identifying an authorized commercial manual for the use of the personnel to whom this equipment is issued.

NOTE

Refer to Tm 9-3415-236-24P for Listing of Repair Parts

Manufactured by: K. O. Lee Company
200 South Harrison Street
Aberdeen, SD 57401

Procured under Contract No. DAAA09-79-C-4623

This technical manual is an authentication of the manufacturers' commercial literature and does not conform with the format and content specified in AR 310-3, Military Publications. This technical manual does, however, contain available information that is essential to the operation and maintenance of the equipment.

Preface and Contents**I. SCOPE AND PURPOSE**

This handbook provides information for operating and maintaining the following model series of Universal Grinders and Tool and Cutter Grinders: B360, BA960, BA962, B2060, B2062, B6060, B6062 Universal Grinders; B300, BA900, B2000, Tool and Cutter Grinders.

Models are manufactured with various suffix letter combinations. Regardless of specific model number, in most instances all portions of this handbook will still be applicable. At the time of printing, the instructions that apply to grinders were accurate, but due to engineering advances, it is possible the machine delivered to you may vary somewhat from the descriptions in this book. In the above listed models, suffixes "X" and "Y" define certain standard models less some standard equipment as defined in the catalogues and price sheets. "H" stands for hydraulically-powered-table-travel. "B" stands for anti-friction table travel or "ball-track" system which became available in 1977. Prior to that, the designation "BB" was used for models which had ball bearing mounted V and flat rollers as table saddle ways. "M" stands for metrically-calibrated-feed-handwheels.

MODEL AND SERIAL NUMBERS are located on a stamped name plate at the rear or side of the machine base on most models.

While it is the purpose of this manual to cover the most typical operations performed on universal tool and cutter grinders, and on machines specifically, it makes no attempt to be exhaustive. It should be taken as a primer on the technology and art of tool room grinding, recognizing that there are often many different approaches to a particular grinding problem. Our goal is to engender familiarity and satisfaction with our machines and tools. To that end, we hope this work will be of value to the beginner as well as the experienced machinist.

Table of Contents

SECTION ONE

	Preface and Contents.....	i
I.	Scope and Purpose.....	i
	Table of Contents.....	ii

SECTION TWO

INSTALLATION INSTRUCTIONS

I.	Uncrating.....	1
II.	Completing Assembly of Grinder Components.....	1A
III.	Foundation and Leveling the Grinder.....	1A

SECTION THREE

LUBRICATION

I.	Initial.....	1B
II.	Hydraulically Powered Machines.....	1B
IV	Lubrication Chart.....	3

SECTION FOUR

GENERAL OPERATION INSTRUCTIONS

I.	Safety Precautions.....	8
II.	Electrical Controls.....	8
	A. Wheelhead and Spindle Motor.....	8
	B. Motorized Workheads.....	9
	C. Hydraulic Machines.....	9
	D. Coolant Systems.....	9
	E. Special Electrical Controls.....	9
III.	Machine Operation.....	9
	A. Table Traverse.....	9
	1. Manual.....	9
	2. Hydraulic.....	11
	B. Crossfeed Traverse.....	11
	C. Column Elevation.....	12
	D. Grinding Heads and Wheel Mounting Procedure.....	12
	E. Swivel Table Adjustments for Taper and Clearance.....	17
	F. Tailstocks and Workheads.....	18
	G. Grinding Wheel Truing and Dressing.....	18
	H. Toothrests and Height Gauges.....	19

Table of Contents

SECTION FIVE

CUTTER GRINDING AND OTHER TOOL GRINDER OPERATIONS

CHAPTER

- 1. Introduction to Sharpening High Speed and Other Cast Alloy Multi-Tooth Cutters..... 21
- 2. Cutter Nomenclature and Measurement..... 32
 - I. Cutter Nomenclature 32
 - II. Cutter Runout Tolerances 35
 - III. When to Sharpen a Cutter 35
 - IV. Cutter Inspection-Clearance Angle Check by Indicator 35
- 3. Plain Milling Cutters 36
- 4. Shell End Mills and Other End Mills..... 38
- 5. Straight Tooth Side Milling Cutters 40
- 6. Stagger Tooth Cutters..... 41
- 7. Angular Cutters..... 42
- 8. Face Mills..... 43
- 9. Form Relieved Cutters..... 48
- 10. Grinding Cutters with Spherical Ends or Corner Radii..... 54
- 11. Reamers 64
- 12. Taps 69
- 13. Cylindrical Grinding and Internal Grinding 75
- 14. Special Operations and Miscellaneous Tool Grinder Setups..... 82
 - I. Cylindrical & Face Grinding of Carbide Milling Cutters 82
 - II. Miscellaneous Cutters..... 84
 - A. Metal Cutting Saws..... 84
 - B. T-Slot, Woodruff Keyseat and Keyway Cutters 85
 - C. Single Point Tools--Use of B945 Tilting Table Attachment..... 86
 - III. Salvaging Tools..... 88
 - A. Salvaging End Mills--Use of Cut-Off Wheels..... 88
 - B. Salvaging Milling Cutters 89
 - IV. Surface Grinding Operations..... 92
 - A. B989 Universal Workholding Fixture 92
 - B. Magnetic Chucks 92
 - C. Wet Wheel Guards 92
 - V. B982 Air Bearing Fixture..... 92

Table of Contents

SECTION SIX

GENERAL INFORMATION, SPECIFICATIONS, FIXTURES & ACCESSORIES

- I. General Specifications..... 95
 - Universal Tool and Cutter Grinders
 - Tool and Cutter Grinders
- II. Machine Standard Equipment..... 96
 - A. Universal Tool and Cutter Grinders..... 96
 - B. Tool and Cutter Grinders..... 99
- III. Tooling and Fixtures and Accessories..... 99
 - A. Workheads for Model Series B300, B360. BA900, BA960, BA962, B2000, B2060, B2062..... 99
 - B. Workheads for Model Series B6060 and B6062 100
 - C. Coolant Systems 100
 - D. Column Extension 100
 - E. Special Toothrest Slide Blade and Arm..... 100
- IV. Machine Adaptability 103
 - A. Adapting a Machine with Heavy Duty Grinding Head to use a High Speed Spindle..... 103
 - B. Adapting a Machine with a Standard Grinding Head to use a Heavy Duty Spindle 103
 - C. Adapting a Tool and Cutter Grinding Machine to become a Universal Grinder 103
- V. Repair Kits and Ordering Parts..... 103

SECTION SEVEN

TABLE OF REFERENCE

- I. Clearance Angles-Straight Wheels..... 104
- II. Clearance Angles-Cup Wheels 105
- III. Clearance Angles-Reamers 106
- IV. Clearance Angles-Carbide Reamers..... 107
- V. Standard Clearance Angle Settings for H.S.S. Cutters and Carbide Face Mills 107
- VI. Clearance Angles-Corner 108
- VII. Wheel R P M./S.F.P.M. Chart..... 109
- VIII. Standard Wheel Shapes..... 110
- IX. Metric and Decimal Equivalents of Common Fractions..... 112

SECTION EIGHT

- Glossary of Terms 113

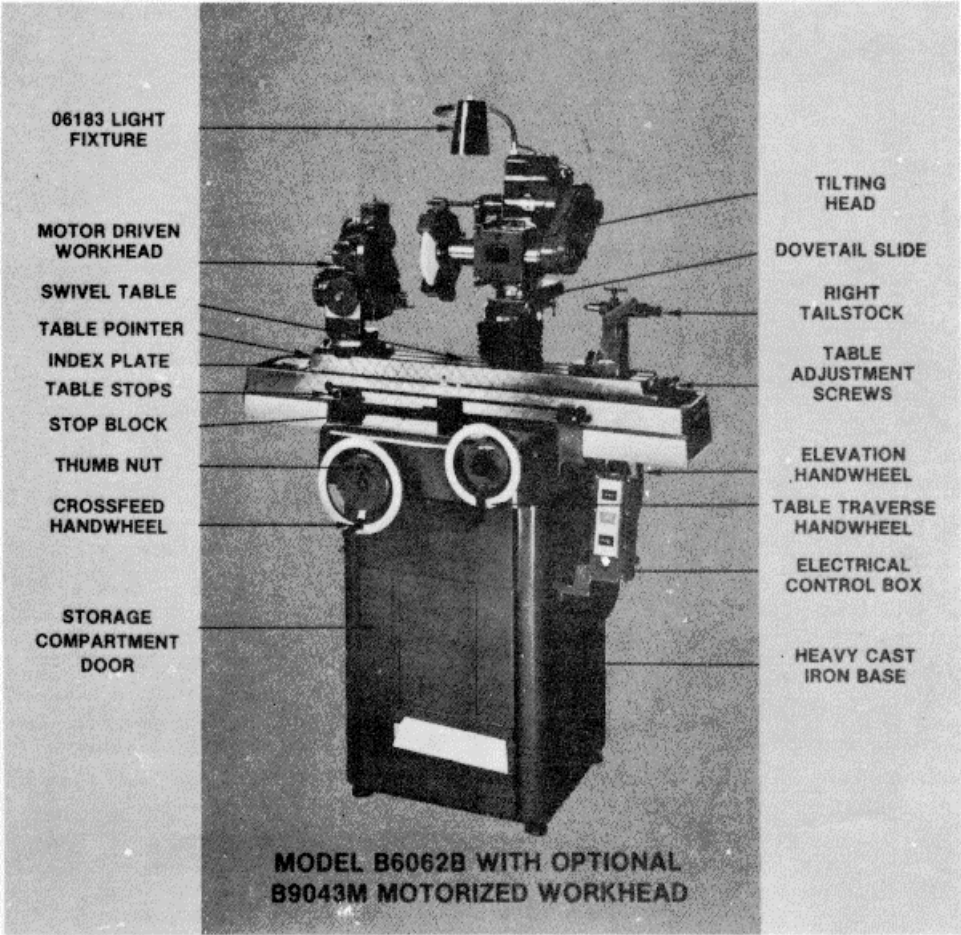


PHOTO 1

-v- (vi blank)

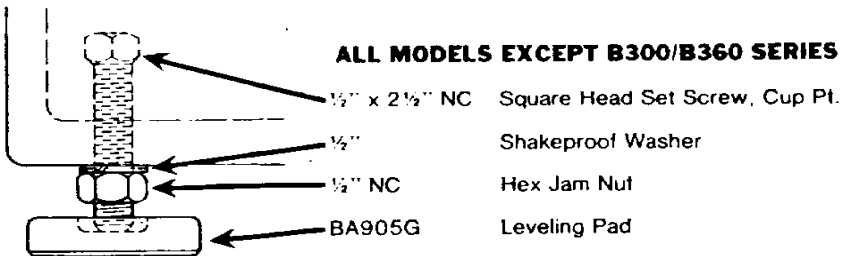
INSTALLATION INSTRUCTIONS

I. UNCRATING

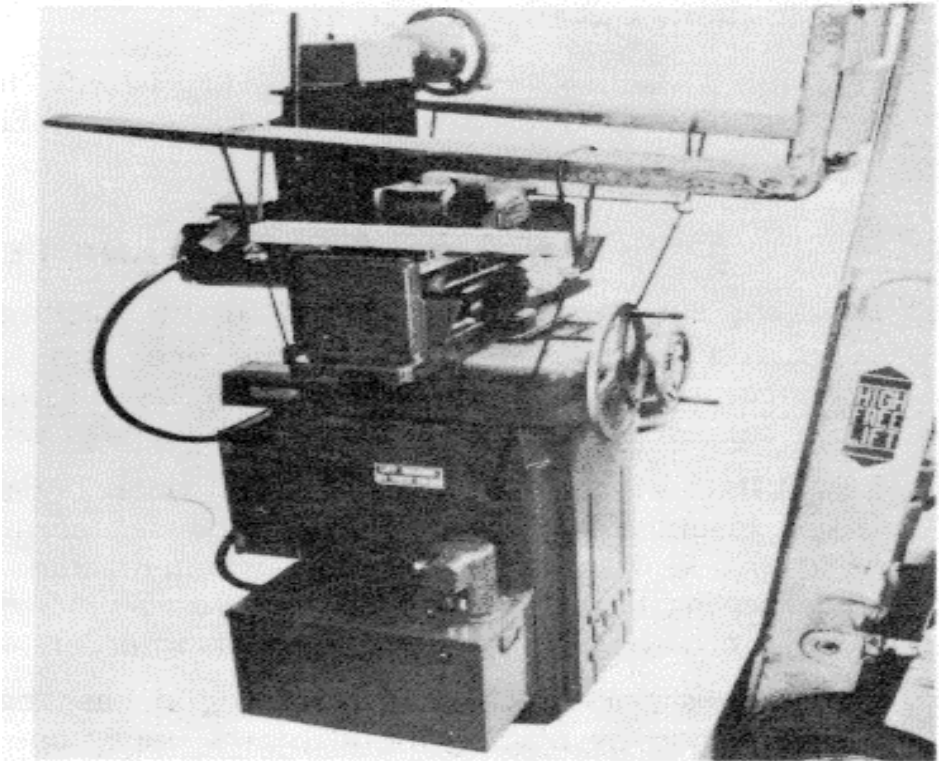
- A. After the top and sides of the crate have been removed from the skid leaving the machine standing free, remove all wrapping materials and read unskidding and lifting instructions attached to machine
- B. Remove bolts holding machine to the skid by holding the bottom of bolt-heads (**under skid**) with a wrench and turning off the nuts from the inside of the base of the machine. Exported models may have bolts passed through skid members. Bolt nuts must be turned off inside the base and machine lifted from the skid.
- C. Lifting, Moving and Leveling Instructions for Models except B300.

- 1. If possible, avoid removing table/saddle hold down bolts until machine is moved to final location
- 2. **Do not attempt to pick up machine by its saddle or table.** Use the two holes on either side of the base cabinet for lifting with cables or ropes when holes are accessible. Use blocks of wood on side of base or between cable to keep them away from saddle sides or table. See suggested procedure for lifting with two cables by forklift below,

3. After the machine has been lifted by cables or ropes and moved to its final position, do not lower until square head set screws inside the base cabinet have been turned down below the bottom of the base, approximately 3/4 inch. Place the washer and hex jam nut on each of the set screws protruding through the cabinet, but do not tighten against bottom of base. Leveling pads, nuts and washers are in marked carton in base cabinet.



D Remove the hold down rods and clamps. Remove any protecting boards. On models with ball bearing mounted tables, do not remove hold downs until machine is located at final spot and leveled.



Instruction Manual**Section Two**

HAND POWERED TABLE TRAVEL GRINDERS WITH BALL TRACK: As soon as you have received your machine, move the table to the extreme right side of the machine, and check the level of way lube in the channel area surrounding the hardened ways in the saddle. This should be maintained near the top of the overflow space cut into the saddle extension casting. The oil provides a washing action on the balls, thus keeping them and way contact line free of dust. Add way lube as necessary. Extra light way lube Part No. 2671 must be used.

- E. Remove the shipping anti-rust lubricant from all non-painted surfaces by using a standard solvent.

II. COMPLETING ASSEMBLY OF GRINDER COMPONENTS

- A. Refer to this manual, pages 96 to 99, or to other grinder literature for correct standard equipment breakdown. Do the same for any fixtures or tooling which are not standard with the machine. NOTE: Check all cardboard cartons for items which are pictured and listed. Check inside of all coolant tanks for parts. Occasionally standard accessory equipment will be included in these cartons.
- B. Pulleys and belts: Place V pulleys on the motor and the quill shafts, using keyed washers and special nuts. NOTE: CHOOSE PULLEYS ONLY AFTER CONSULTING THE MACHINE R.P.M. CHART. Visually check the alignment by rotating the motor shaft by hand or by power with the belt in place.
- C. Consult Section Four, Part III, pages 13 to 17 for the installation of wheel and pulley arbors onto spindle shafts.
- D. Hydraulic Machines: See pages 6, 11, 12 of "Instruction Manual" HPL-3 for installation and trouble-shooting information. See Section Four, Part III, page 11 for operating instructions.

III. FOUNDATION AND LEVELING

- A. Read any set-up instruction cards on the machine. The base of most models is supported by four cast pads on the floor and four leveling screws turned into each corner of the base. If a spirit level reveals that the table is not level, make adjustments according to machine tags or "B" below.
- B. LEVELING: Place leveling pads on floor underneath the bolt locations and lower machine carefully. Adjust the set screws by wrench on their square head, inside of base cabinet, and when machine is level, lock the hex jam nut underneath the cabinet on all four screws. See diagram on page 1. All four screws must be firmly contacting pads in order for machine to function properly.
- C. B300 series grinders have three integral base cabinet pads. Leveling must be accomplished by placing metal plates under one or more of the pads.

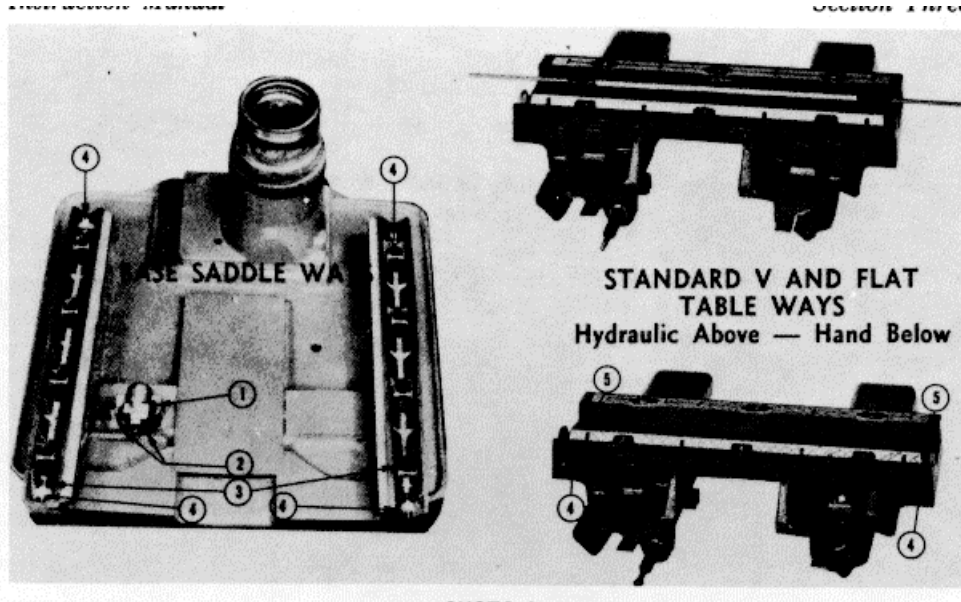


PHOTO 2

LUBRICATION

I. INITIAL

grinders are made with a variety of lubrication systems, but the standard design features a self-lubrication principal of spool rollers working in lube reservoirs (photo 2). Ways are kept wet and clean by movement action of the saddle and table. Check all machine-way surfaces for wetness of oil by traversing the saddle and table. Standard machines are shipped with an adequate supply of way lube in the lubrication system, as are machines with one-shot or electrically powered lubrication. Column-way surfaces, nut, and screw are covered with preservative oil. The B6000 series grinders have a built-in reservoir for light way lube for the column screw and nut.

Hydraulic machines are not shipped with hydraulic oil, but base-ways and column-ways are lubricated by spool rollers or other systems. Note that all "V" way ends have a nylon spring loaded plug to wipe way oil from corresponding saddle or table "V" as shown in photo above. Extra way-lube oil is sent with the machine in a separate container.

II. HYDRAULICALLY POWERED MACHINES

The "Instruction Manual, Hydraulic Parts List, Coolant Parts List" (HPL-3) which comes with the machines discusses set-up and maintenance of the hydraulic system. **Consult Lube Chart, page 5 for remaining points on lubrication of hydraulic models.** The main item of concern is to keep the longitudinal table ways wet with clean oil

from the hydraulic system. Valve No. 18 pictured on the Hydraulic Pump and Tank Assembly, shown in Photo 5, is used to regulate the flow of oil and has been properly set at the factory for the correct grade of oil at normal operating temperature.

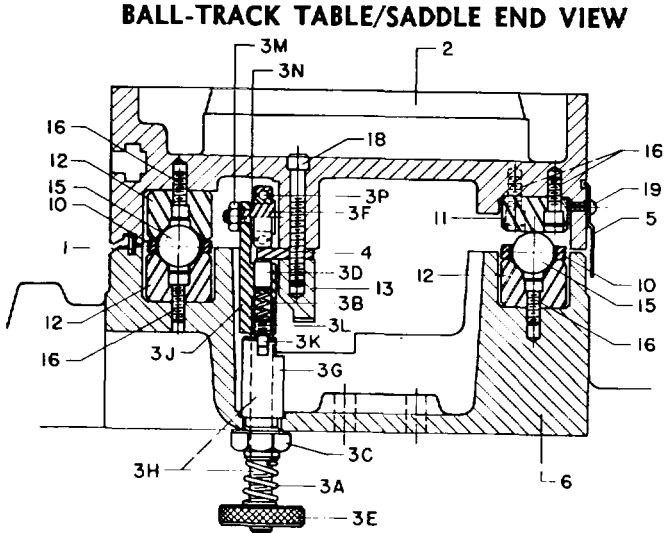
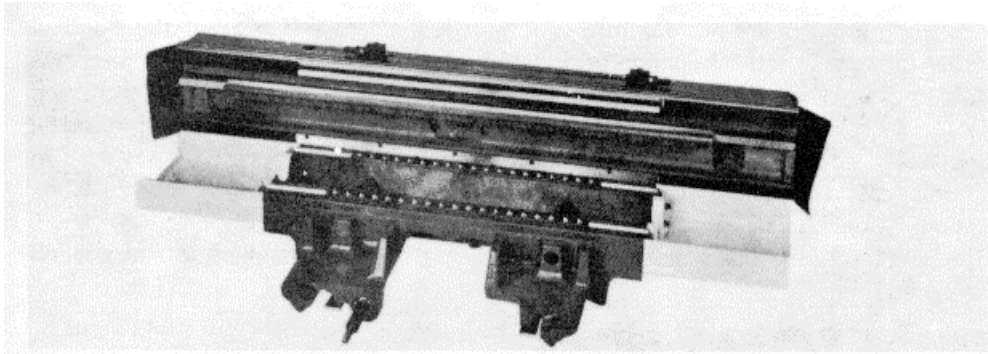


PHOTO OF TOP OF BALL-TRACK SADDLE



III. BALL-TRACK HYDRAULICALLY POWERED MACHINES OR MACHINES WITH PRESSURE LUBRICATION SYSTEM

- A. These models have special piping to the center of the "V"-ways, and receive regular amounts of oil or way lube from the hydraulic system or power way lube system. Periodic inspection is advisable and may be done in the following manner.
- B. It is necessary to disengage the piston rod from the table at the right end of the table. Remove the thumb nut, move the table slightly further to the right, and remove the collar from the piston rod (reach under the table end to locate on rod). Move the table to the extreme right until the saddle table way reservoirs

Instruction Manual**Section Three**

become visible. The level of lubrication should be maintained at the top of the overflow, cut-out section of the saddle extension casting. With hydraulic machines, the level of way lube is approximately $\frac{1}{2}$ " deep from the bottom. If the level appears to be low, adjust oil flow valve for the ways, (Part No. BA931W, Index No. 18, page 7) on hydraulic tank for increased flow to table reservoirs. Similarly, attempt to determine if pressure lubrication system (one-hot, automatic one-shot, etc.) is putting out the proper amount of way lube. Adjust as necessary.

SUGGESTED INSPECTION AND CLEANING SCHEDULE

Monthly:

- A. Ways should be inspected at least once per month if the machine is in continuous use.
- B. Clean the bottom of the hardened TABLE "V" and flat ways, at least once per week by moving the table to the extreme ends of its travel, left and right, and wiping the ways with a clean cloth.

Yearly:

- A. Clean out the hollow SADDLE EXTENSIONS on each side of the table. Move the table to one end and then the other, uncovering these extension areas. These hollow extensions will accumulate some dirt and oil drippings from the ways, and need to be cleaned periodically. Extensions are drained back into the saddle on hydraulic models.
- B. Remove the table from the saddle by removing the hand nut (Index No. 3E) from the table roller hold-down tension rod end (Index No. 3H), under the saddle, by counterclockwise turns. Be careful to disattach all items attached to the table, such as coolant guards and the hydraulic piston rod. Remove the tensioning spring and lift the table straight upward until the hold-down rod clears the saddle sleeve hole. NOTE: Because of the nylon tensioning plugs, the entire assembly will hang onto the gear rack steel hold down bar (Index 4, page 2). Set the table on its side and inspect its ways for wear. Inspect the hardened ways and balls in the saddle for signs of wear. Clean out the saddle table and balls. Clean out the saddle table way reservoirs. Replace with clean oil or way lube, and replace the table back onto the saddle by reversing the steps just taken to remove the table. Tighten the hand nut of the table roller hold-down assembly until the spring is fully compressed, and then loosen it by approximately $\frac{1}{4}$ of a turn.

IV. LUBRICATION CHART

Refer to the number in Photo 3, and follow the Instructions and Specifications in the chart.

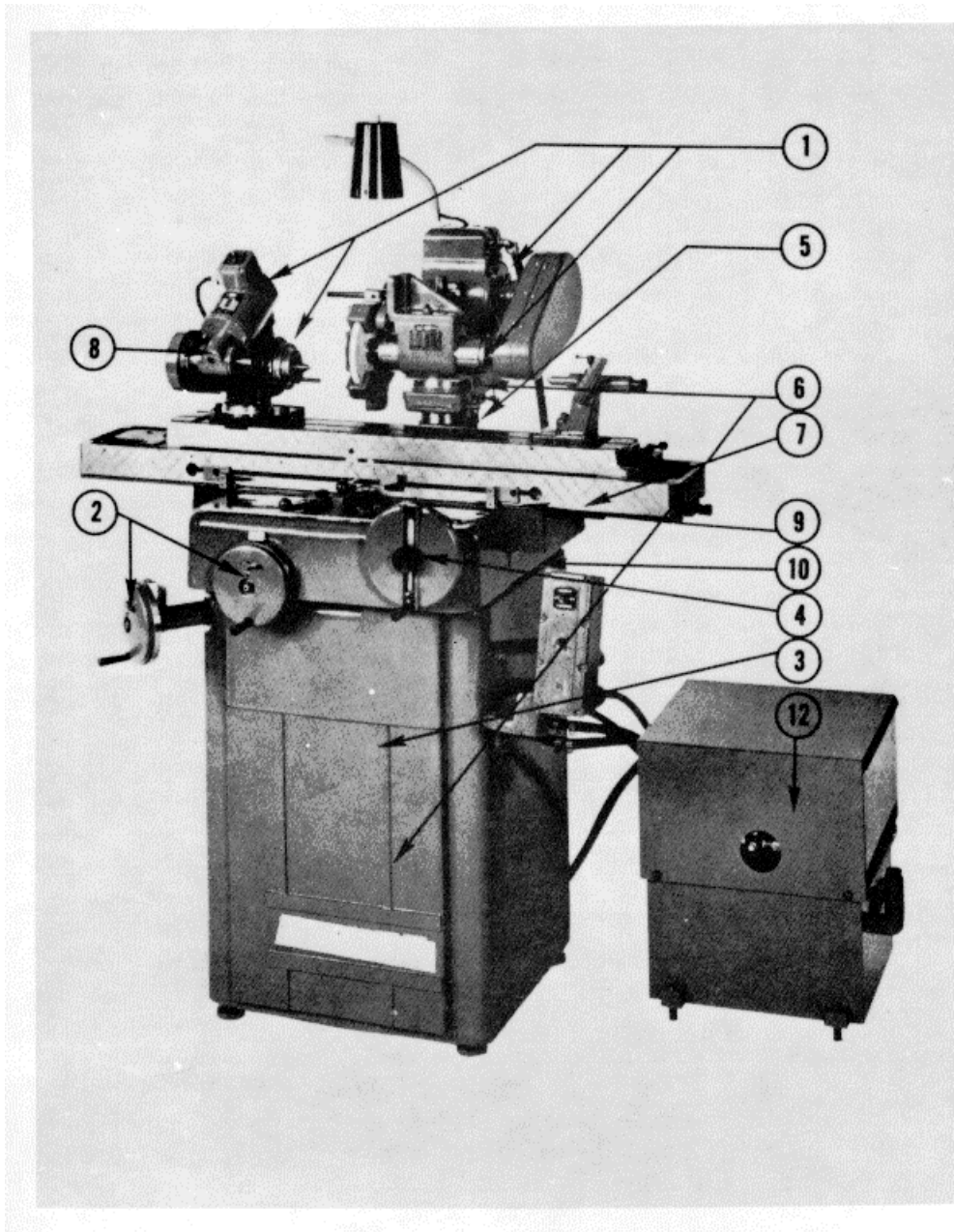
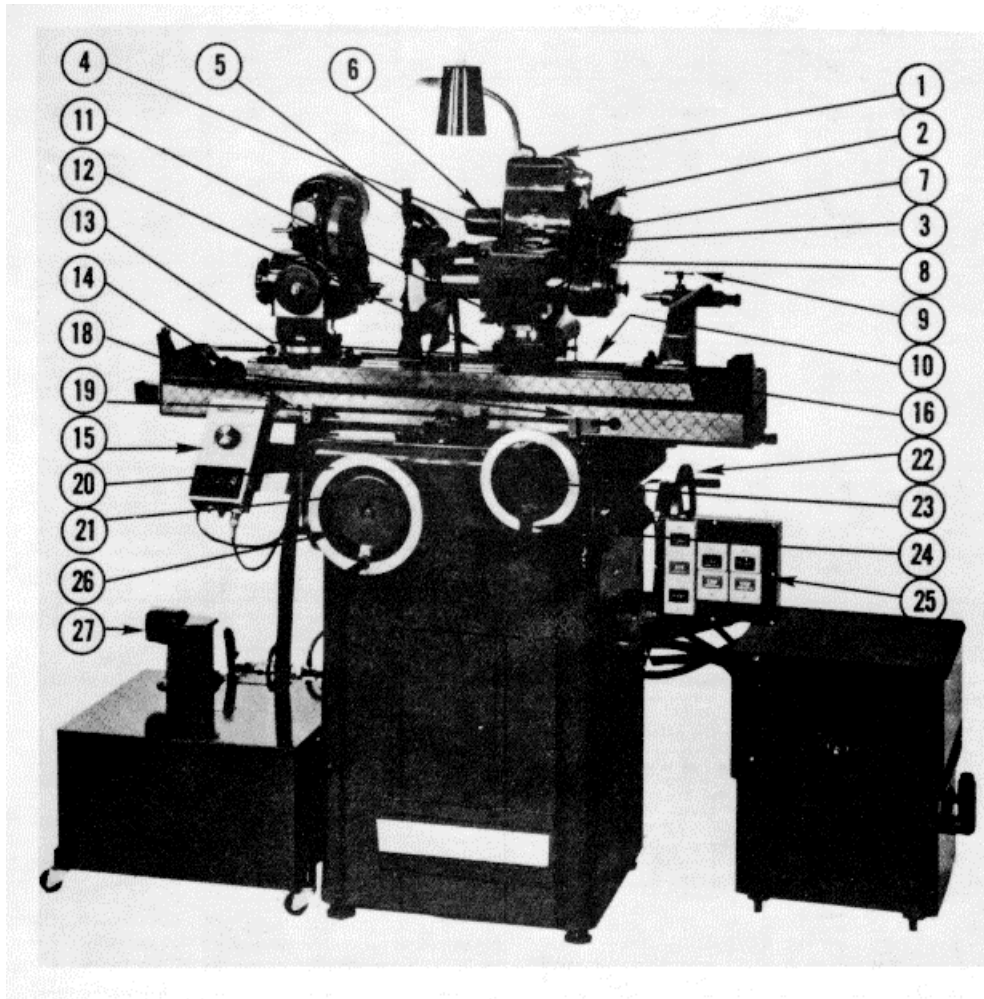


PHOTO 3

LUBRICATION INSTRUCTIONS AND SPECIFICATIONS

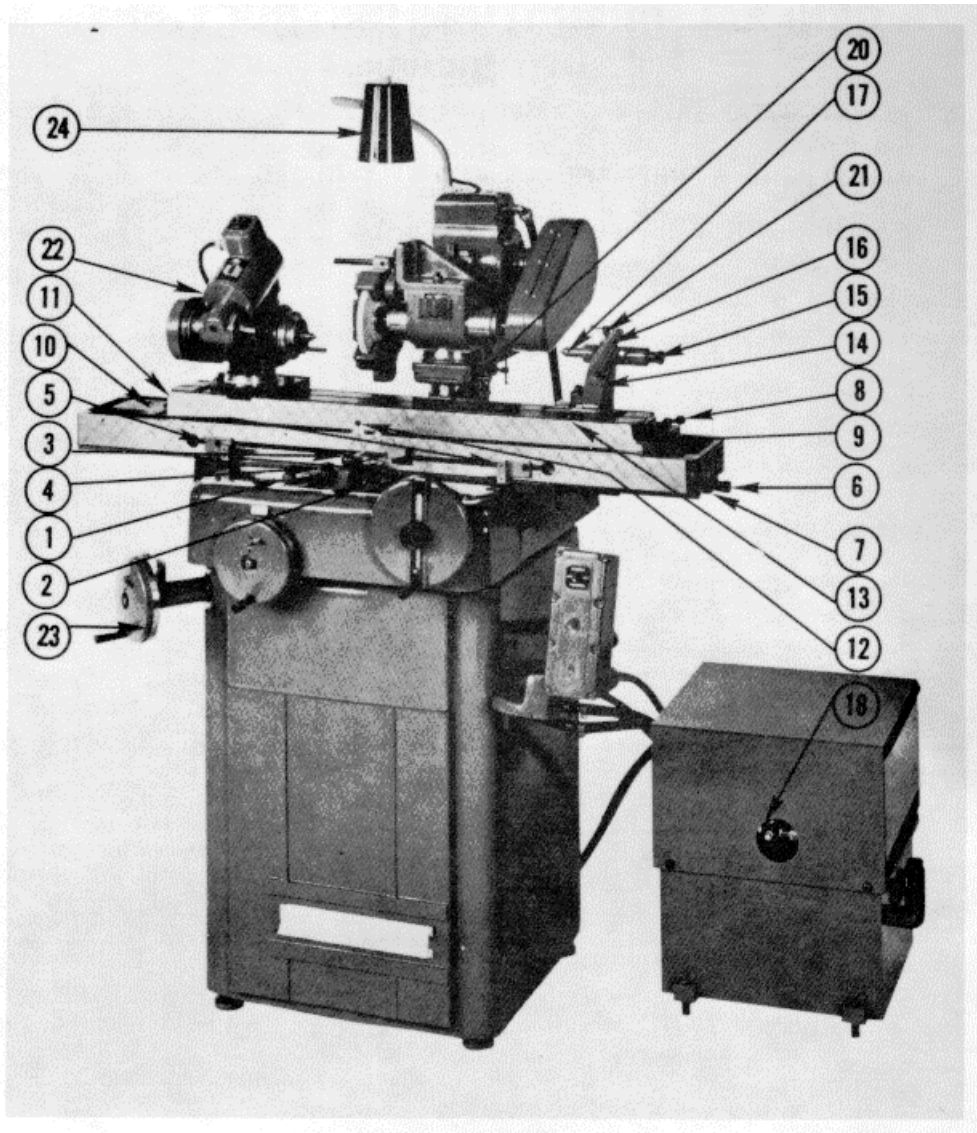
Station Numbers	Parts Lubricated	Machine Model	When To Oil	Procedure	Lubricant Specification
1 2	Motor and spindle bearings: dead center for workheads, and all workheads with ball bearings Crossfeed and elevating gears bearings	All Models		None	Factory grease packed for life of bearings
3	Elevating gears	B300 Series BA900, B2000, B6000 Series	Every 6 Months	Service by removing rear plate or thru front cabinet door -Clean and repack Service by entry thru front cabinet door.	Crease, calcium base 340 viscosity
4	Transmission for table	All models	Check Yearly	Remove filler plug screw and fill to 1/2" from top	Factory sealed with 600W Cylinder Oil
5	Column O.D.	BA900, B3300, B2000 Series B6000 Series	Yearly Monthly	Slip down column boot, wipe O.D with oiled cloth. Fill through oil cup on column housing.	Light way lube
6	Column screw and nut Column screw and nut	B300, BA900, B2000 Series B6000 Series	Every 6 Months to 1 Year Yearly	Remove grinding head, remove column cap, brush screw with lube Column has built-in reservoir with wick Fill thru center hex hole in pivot stud under dovetail slide-1/2 pint capacity	Light way lube Light way lube
7	Gear rack	All models	Monthly	Brush clean, oil by moving table to ex-o	Clinging grease
8	Gear reduction drive	All motorized workhead models	Check Yearly	Fill through screw plug up to bottom of filler hole.	600W cylinder oil
9	Table Saddle Ways (See photo 21 See photo 21 Table Saddle Ways (See Photo 2) Table saddle ways. base ways, feed screw and nut	B300, BA900, B2000, 86000 Series Std "V" and Flat Ways Ball Track Models BA900B, B2000B, B6000B Series All hydraulic models Optional One-Shot Lube - All Models	Every 1 to 6 months depending on usage Monthly Check Every 6 Months See Instruction on Machine	Ways are roller lubricated. Remove table, clean reservoirs, fill with lube. Feel ways, they must run wet. See page 3 111 for table removal. No way lube required. Ways are self-lubricated from hydraulic system page IB, II. Pull plunger as per machine instruction Electric units - self timed	Light clinging way lube 2671 Extra Light Way Lube only Hydraulic oil See Light clinging way lube
10	Base saddle ways See 31 photo 21	All Standard Models All Hydraulic Models	Every 6 Months to 1 Year	Move table to extreme right and left exposing oil reservoir tubes in saddle. Pour oil into tubes (see 15) photo 21 until oil runs from either end of V-ways On 8300 Series, move saddle to extreme outward position, fill reservoir through tubes, return saddle to extreme Inward position: repeat filling procedure. NOTE If base ways are very dirty, remove saddle by removing bolts holding saddle feed bar I(from underneath base top), that holds the bronze crossfeed nut in position Slide saddle front; remove. Clean channel ways, fill to bottom of "V", keep nylon plugs in	Light way lube Each way holds approximately 1 pint
27 Photo 4	Motor and pump	Coolant Attachment -- All Models		None grease-sealed	Factory
12	Hydraulic pump motor	All Hydraulic Models		Check motor, add oil as directed, or yearly.	Motor Oil, S.A.E. No. 10



MODEL B6062H WITH B10043M MOTORIZED WORKHEAD

PHOTO 4

- | | |
|---|---|
| 1. Switch on Machine with Toggle Switches | 14. Table Index Plate |
| 2. Belt Guard | 16. Table Adjustment Screws |
| 3. Tilting Degree Dial | 18. Adjustable Stop |
| 4. Cartridge Spindle Locking Screw | 19. Table Stop |
| 5. Wet Wheel Guard | 20. Crossfeed Handwheel |
| 6. 8923CL Motor Shaft Guard | 21. Thumb Nut |
| 7. Guard Mounting Bracket | 22. Elevation Handwheel |
| 8. Swivel Socket Screws | 23. Knurled Knob to Engage Drive |
| 9. Tailstock Locking Screw | 24. Table Traverse Handwheel |
| 10. Rear Column Lock Screw | 25. Electrical Control Box |
| 11. Hex Nut | 26. Movable Index Disc |
| 12. Swivel Locking Nut | 27. On-Off Coolant Switch if specified on
Coolant Tank |
| 13. Dovetail Slide | |



MODEL B2060H

PHOTO 5

- | | | |
|----------------------------|-----------------------------|--|
| 1. On-Off Valve Control | 9. Clamp Bar Socket Screws | 17. Tailstock Center |
| 2. Speed Control | 10. Index Plate | 18. Oil Flow Valve for Ways
remove cover for adj. |
| 3. Directional Control Arm | 11. Pointer | 20. Swivel Table |
| 4. Dwell Control | 12. Friction Socket Screws | 21. Tailstock Locking Screw |
| 5. Table Stops | 13. Hex Socket Screw | 22. B943 Motorized Head |
| 6. Hyd. Cylinder Thumb Nut | 14. Spring Center Tailstock | 23. Elevation Handwheel |
| 7. Rod Drive Collar | 15. Threaded Plunger | 24. 06183 Light Fixture |
| 8. Swivel Table Adj. Screw | 16. Tailstock Lever | |

GENERAL OPERATION INSTRUCTIONS**I. SAFETY PRECAUTIONS**

- A. **ALWAYS WEAR SAFETY GLASSES** or an eye shield when operating a grinding machine.
- B. **ALWAYS USE A WHEEL GUARD AND BELT GUARD.** Machines are provided with wheel guards of the correct size and necessary mounting brackets. Consult Part III of this section and general set-up -photos in this manual on how to attach these to the machines.
- C. Mounting Wheels
1. Check wheel R.P M. charts on the machine or Part 111, pages 14, 15 of this section for the correct or maximum safe speed for the size and type of wheel being used. Do not exceed this speed or the speed marked on the wheel or its blotter The R P M listed is the maximum safe speed for a given new wheel diameter.
 2. Inspect all grinding wheels prior to mounting. Use the following check for cracks or vitrified bond wheels: Hold the wheel by a small shaft through its hole, and then tap the edge with a non-metallic object. An undamaged wheel will sound a clear metallic ring. Check resinoid bond wheels and other types of wheel bonds by visual inspection.
 3. Never alter the hole in the wheel or force the wheel on the spindle.
 4. Use one clean, smooth blotter on each side of the wheel under each flange
 5. Tighten the arbor nut only enough to hold the wheel firmly.
 6. Stand back and out of plane of the wheel when first starting the grinding spindle (WHEELHEAD MOTOR). Allow the motor to operate for about a minute prior to grinding.
 7. Special caution is needed when grinding on the side of the wheel. Wheels with flat sides may have sufficient side "run-out" to necessitate truing the side with a dressing stick A slightly hollow recess to within t,6 inch of the periphery of the wheel is recommended to limit the amount of side thrust on the wheel. Use saucer wheels whenever possible for side grinding.
 8. Store wheels in a safe place (FREE FROM EXTREMES OF HUMIDITY AND TEMPERATURE) near the grinding machine.
 9. See Part 11 in this section for procedures on mounting, truing, and dressing wheels NOTE' Wheel arbor clamping flanges must be the same diameter inside and outside. The wheel collet or arbor O.D. should vary with the wheel diameter. Safety codes recommend a diameter equal to not less than ' of the diameter of the wheel.
- D. We recommend a dust collect system for use with dry grinding
- E. Rings, wrist watches, or loose long-sleeved shirts are hazardous items to wear during grinding operations.

II. ELECTRICAL CONTROLS

Before starting machine, learn the location and function of each electrical switch. **(REFER TO NUMBERED POSITIONS IN PHOTO 4.)**

- A. Wheelhead and Spindle Motor: Machines with standard toggle switches have the switch located at point (1). This switch, located on the top of the motor

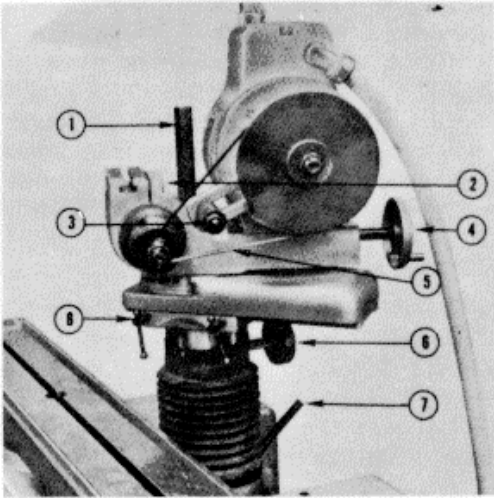
Instruction Manual**Section Four**

housing, is a "Forward-Off-Reversing" type with the "Off" position in the center. Spindle motors should be completely stopped in one direction prior to reversing. Check the rotation of the spindle for "Forward" switch designation. Rotation should be down at the point of grinding as one faces the wheel periphery, with the spindle parallel to the grinder table. Some machines have a standard push button box on the side of the machine at (25) with three positions, "Start-Stop-Reverse." The function of any other switches at this point is described on the station box. Special electrical controls consisting of push button and other types of switching are located at position (25).

- B. Motorized Workheads: Units with toggle switches have the switch located at top of unit and these are "Forward-Off-Reverse" switches. **WARNING:** Prior to turning on the workhead motor, make sure the spindle is free to turn - that the spindle lock is loose. Workheads may plug into the machine or have a separate wall plug. Some motorized workheads that plug into the machine electrical panel have "Forward-Off-Reverse" switches at position (25).
- C. Hydraulic Machines: These machines have "On-Off" switches, toggle or other type located at (25). **WARNING:** Prior to switching on hydraulic motors, check the hydraulic tank for adequate oil and make sure valves are in the "off" position. See the special instructions on the operation of hydraulic grinders, Part III, A-2 of this section.
- D. Coolant Systems' Coolant pumps may have "On-Off" switches at position (25) or at the pump unit itself at (27). Coolant systems plug into the machine electrical panel or have separate plugs for wall connection.
- E. Special Electrical Controls. Some machines have special starting motor controls which may feature other types of switches than the standard toggle switch. Machines may have "overload-under-voltage" magnetic starters located apart from the motor or its usual switch location. Other machines will have magnetic starters for each motor located in a I I.C oil tight junction box at the rear of the machine. These systems may or may not feature power transformers for lower voltage starter circuits. With these controls, special switches are located at (25) for starting and stopping motors.

III. MACHINE OPERATION

- A. **(REFER TO PHOTOS 1, 4, 5, 6 and 7)** Table Traverse: This main control is located at position (24) Photo 4 on most machines and consists of a two-speed transmission and handwheel. Some machine models also feature one or more rear-operated, single speed table controls consisting of handwheel and friction lock-in or lock-out shaft and pinion. The B6060 and B6062 series grinders have a swing handle adjustment, while all other models have friction-slide extending handles.
 1. To effect manual table traverse, engage the transmission as follows:
 - (a) B300 Series-The transmission is shipped with gears in neutral position. To engage direct drive, turn and push in the handwheel (24) Photo 4 until spring loaded ball is felt dropping into a groove on the transmission shaft. To shift to low ratio, pull the handwheel out. As the shaft and handwheel move out of the neutral groove, the low ratio groove will be felt. Handwheel, shaft, and pinion are positioned relative to the gear rack by the ball riding in a groove on the shaft.



- 1. B855Y Special Nut
- 2. 6 x /4 NF Hex Socket Cap Screw
- 3. B860GN Special Nut
- 4. Belt Adjustment Handwheel
- 5. V-Belt
- 6. Eccentric Shaft Hand Nut
- 7. Column Lock Lever
- 8. B955G Lock Screw Assembly

PHOTO 6

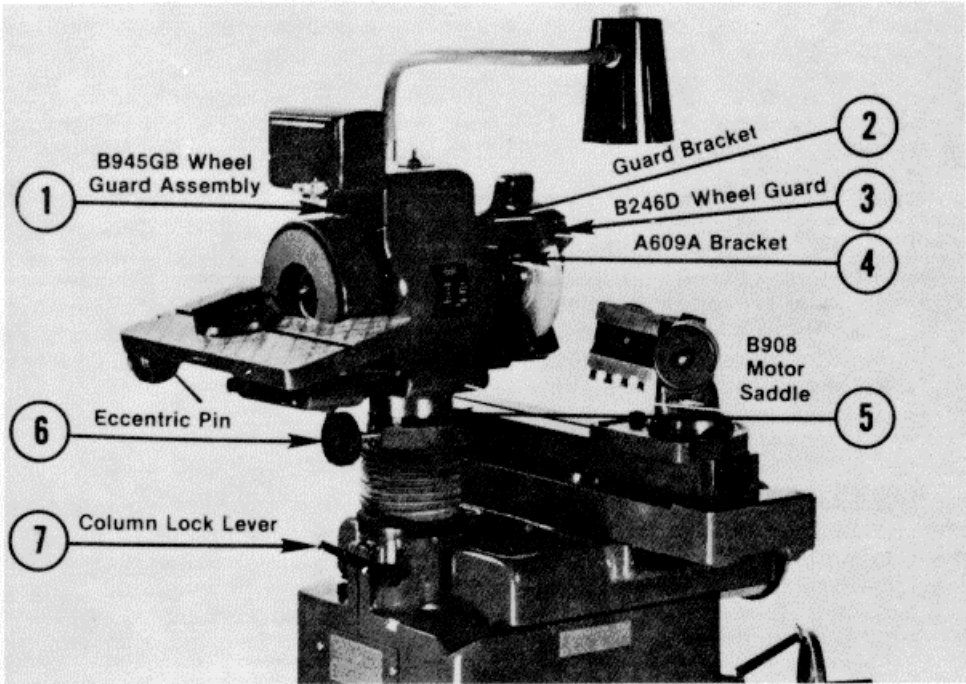


PHOTO 7

(b) All Other Models: The transmission is shipped with gears in neutral position. The pinion gear is off the rack. To engage the direct drive ratio, turn and pull the knurled knob (23) Photo 4 to start the pinion onto the rack. Continue to pull while oscillating the handwheel until an inner key is felt dropping into the direct drive slot. To engage the low ratio, continue pulling the knob while oscillating the

Instruction Manual**Section Four**

handwheel until the key in the transmission drops into the low ratio slot. To shift from the low ratio, push in the knurled knob while oscillating the handwheel. Not over 1/2 turn of the handwheel is necessary to shift into either of the two ratios.

- (c) Use of the hand operated table transmission on machines with hydraulic power. Make sure that the hydraulic motor is turned off. Move control (1) Photo 5 to "Off". It should now be possible to move the table easily when the manual transmission is engaged in the low ratio. If it is desired to avoid the hydraulic oil friction caused by oil being pushed by the cylinder piston, disengage the thumb nut (6) Photo 5 from the piston rod at the right side of the table. Move the table slightly to the right so as to pass the rod end through the yoke; then remove the rod drive collar (7) Photo 5 from the rod. This will enable the table to be moved without moving the piston and rod assembly.

2. Hydraulic Table Traverse: To engage the hydraulic power for traverse of the table, follow these steps,

- (a) Set out to the ends of the table stops number (5) Photo 5 or remove them from the table altogether. Disengage the hand operated table transmission described in 1, (a) and (b) above.
- (b) With "On-Off" valve (1) Photo 5 in the "Off" position and Speed Control (2) Photo 5 at a low setting of about one or two on its dial, turn on the hydraulic pump motor and allow the system to warm up for 15 to 30 minutes.
- (c) Turn valve (1) Photo 5 to "On" and allow the table to traverse to the furthest point in each direction for a few minutes. When the table has stopped traveling in one direction, move the Directional Control Arm (3) Photo 5 to point in the opposite direction, and the table will reverse. This action purges the table cylinder of any air that may be in the system.
- (d) Re-set the table reversing stops relative to the work that is to be ground and tighten with a hex wrench.
- (e) Set the table travel reversal Dwell Control (4) Photo 5 for the amount of dwell desired at the end of each table traverse. The dial for this control allows up to two seconds of dwell (TABLE STOP) before the table starts back in the opposite direction. **NOTE:** The "Instruction Manual...HPL-3" which comes with the machine gives basic set-up and maintenance information of the system.

- B. Crossfeed Traverse. The handwheel for actuating the machine saddle either toward or away from the column is located at the same position(s) on all grinders at the left front (20) Photo 4 and on some machines also at the left rear part of the machine. On most machines, this handwheel has a movable index disc (26) Photo 4 graduated in thousandths--one hundred to a revolution. The disc is moved by releasing a thumb nut (21) Photo 4 allowing the operator to set the crossfeed at zero at any saddle position for measurement beyond this point. The B300 and B360 Series grinders have the index dial integral with the handwheel. The feed nut which is a floating type, is split and held together with two screws (2) Photo 2 for backlash adjustment. Screw (1) Photo 2 is an adjustment for the amount of "play" between the

Instruction Manual**Section Four**

stationary bar which keeps the nut from moving and the nut itself. This latter screw has been factory adjusted for very minimal movement of the nut relative to the bar. Normal backlash in the nut is about .005 inch

C. Column Elevation:

1. All B300, B360, BA900, BA960, BA962, B2000, B2060, and B2062 series grinders: The elevation handwheel, located at (23) Photo 5 and on some machines also at the center of the machine base just below the column, has an index disc calibrated in thousandths -fifty to a revolution. B300 and B360 series grinders have the index dial integral with the handwheel. The index disc and releasing thumb-nut are the same as on the crossfeed handwheel. These machines with a 4 inch column have a column lock lever at the rear of the machine (7) Photos 6 and 7 which is used to lock the column in at a fixed location for cylindrical grinding and on operations where vertical movement of the column is critical. During surface grinding activity, use the column lock under partial tension before downfeeding onto the work.
2. B6060 and B6062 series grinders: The elevation handwheels are located at (22) Photo 4 and have index discs that are calibrated in thousandths - fifty to a revolution. The index disc and releasing thumb-nut are the same as on the crossfeed handwheel. These machines are provided with a rear column lock screw at (10) Photo 4 for operations that require a fixed column setting.

D. Grinding Heads:

1. **TOOL AND CUTTER GRINDERS:** Models B300, BA900, and B2000 have a motorized dual-wheel grinding spindle and motor saddle (5) Photo 7 attached directly to the top of the column. This entire assembly is held in place by an eccentric pin at (6) Photo 7 which passes through the column wall, through the hold-down cage attached to the motor saddle, and then into the inner wall of the column. When this shaft and hand-wheel are rotated in either direction sufficiently, the grinding head assembly is held rigidly in place. If only a slight amount of shaft rotation is used, the head can be swiveled in the horizontal plane 360 degrees. The column top is calibrated in degrees and the motor spindle shaft may be positioned to any angle relative to the table and locked in place. Holes in the pin handwheel are provided for use with the handle of the 8628 wrench for additional tightening of the grinding head to the column. Wheel guards shown in Photo 7, are mounted to bracket arm A609A (4) or the B945GB bracket (1) (FASTENED TO THE MOTOR HUBS) by means of a wheel guard assembly. Use the B855W open-end wrench, standard T-slot bolts, and the S894 wrench to tighten the hex socket screws and hex nuts.
2. **UNIVERSAL GRINDERS:** Models 8360, BA960, BA962, B2060, and B2062. These models use a universal grinding head (**B955 or B955HD**) which features a motor-driven grinding spindle using a V-belt.
 - (a) Spindle Speeds: The R P.M. is changed by changing the pulleys attached to the spindle and motor. Always use the keyed washers on the outside of the pulley before turning on the locking nut. Remove the belt guard by removing the nut (3) Photo 6 from the T-slot bolt held in the A60c9A T-slot arm bracket. This bracket slips over the motor hub and is adjustable by a locking hex socket screw. A belt

tightening screw and handwheel (4) Photo 6 is used to move the motor relative to the spindle for installing and tightening the belt. Always leave enough slack in the belt tension so that the belt can be depressed to a depth of 3/8 to 1-2 inch between the two pulleys on one side. Use the edge of the wheel guard as a straight edge between the periphery of the two pulleys. Mount the V-groove pulleys with the hub flanges on the same side. Check the alignment of the pulley grooves by running a straight edge between the two pulley sides. To make adjustments, move the spindle relative to the spindle bracket housing by loosening hex socket screws (2) Photo 6. **WARNING:** Do not over tighten these spindle bracket screws, as damage to the spindle bearings may result. Tighten these screws until the spindle cannot be made to slip or rotate in the bracket housing by hand pressure

- (b) Grinding Head Swivels' The lower swivel adjustment (6) Photo 6 is the same as that described for the models in D-1 above. The upper swivel on the universal head is movable when special nut (1) Photo 6 is loosened with the B855W machine wrench. The upper swivel allows the spindle bracket housing (THUS SPINDLE AND MOTOR) to swivel 360 degrees relative to the dovetail slide in the horizontal plane.
- (c) Dovetail Extension' The universal head is made with a dovetail slide (13) Photo 4 which allows the movement of the spindle relative to the column (IN ANY DIRECTION OF THE WHEELHEAD SWIVEL) up to 6 inches. With the slide all the way to the rear of the machine, the center-line of the spindle is approximately in the vertical plane of the edge of the column. Movement is by hand pressure upon loosening of the two handle lock screws (8) Photo 6.
- (d) Spindles and Wheel Mounting:
 - i. High Speed for Standard Universal Grinders with B955 Head:
 The B6055B cartridge spindle (Photo 8) has a normal speed range of 3450 to 18,400 R.P.M. Mount belt pulleys as shown in Photo 8 at the right of the spindle. Mount the spacer washer first, then the pulley, and then the keyed wheel flange and nut. Use the B628 Wrench while holding the pulley by hand or holding the shaft stationary with the B936W Spanner Wrench.
 The B855F pulley and wheel arbor shown in Photo 8 attaches to the internal taper lock at the left end of the spindle by means of its inner hex socket screw. Always clean the taper surface prior to mounting arbors. The S894 Hex Wrench is used for tightening this screw while the spindle shaft is held at the right end by an open-end wrench. Using the B628 wrench, the arbor nut, and keyed flange, any 1/2 inch bore diameter wheel can be mounted on the arbor. Mount straight wheels of no larger diameter than 5 INCHES on this arbor. See Part I of this section for safety precautions when wheels are being mounted. **NOTE:** It is also possible to mount wheels at the right end of this spindle while using the B855F arbor to hold the pulley, so that the motor can drive the spindle from the left end. This makes it possible to mount a wheel further away from the machine column without reversing the spindle in the spindle housing bracket

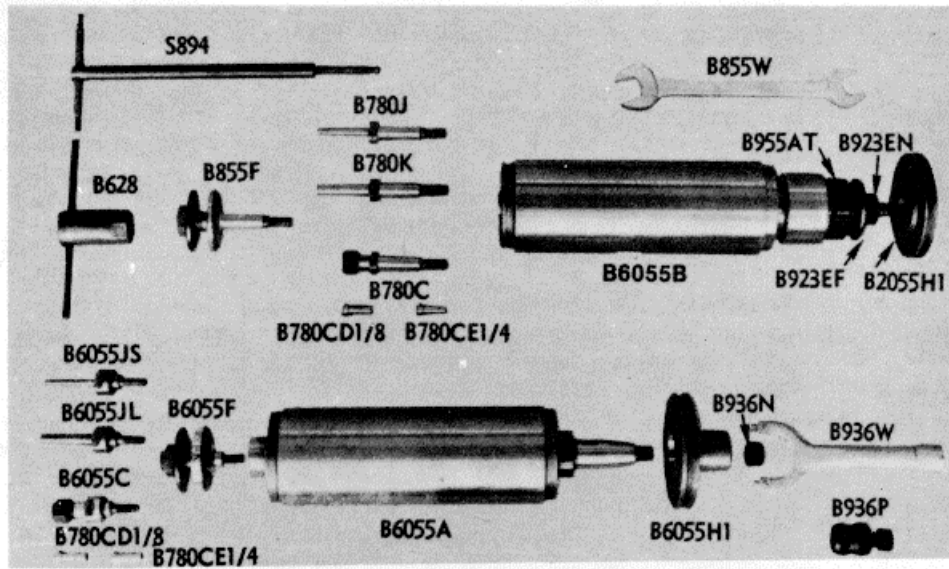


PHOTO 8

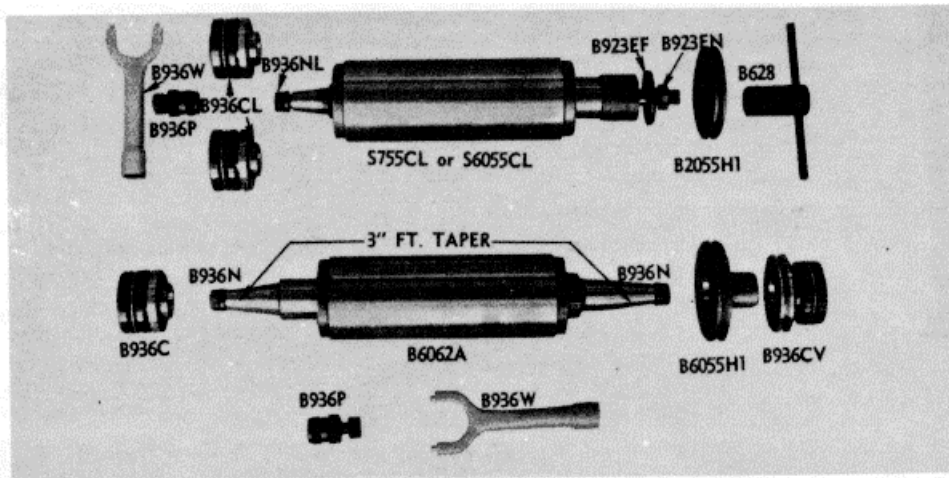


PHOTO 9

Diameter of Wheel	Wheel Speed R.P.M.	Pulley on Motor 3450	Pulley on Spindle	Belt Used
6 to 5	3,450	3 $\frac{3}{8}$	3 $\frac{3}{8}$	5M615
5 to 4	4,600	4 $\frac{1}{2}$	3 $\frac{3}{8}$	5M670
6 to 5	3,450	2 $\frac{1}{2}$	2 $\frac{1}{2}$	5M560
4 to 3	5,820	3 $\frac{3}{8}$	2	5M615
3 to 2	7,760	4 $\frac{1}{2}$	2	5M710
2 to 1 $\frac{1}{2}$	10,350	6	2	5M670
1 $\frac{1}{2}$ to 1	13,800	6	1 $\frac{1}{2}$	5M670
1 to $\frac{3}{4}$	16,560	6	1 $\frac{1}{4}$	5M670
$\frac{3}{4}$ to $\frac{1}{2}$	18,400	6	1 $\frac{1}{8}$	5M670

Diameter of Wheel	Wheel Speed R.P.M.	Pulley on Motor 3450	Pulley on Spindle	Belt Used
	1,150	2	6	5M710
	2,580	3 $\frac{3}{8}$	4 $\frac{1}{2}$	5M670
7 to 5 $\frac{1}{2}$	3,450	3 $\frac{3}{8}$	3 $\frac{3}{8}$	5M615
7 to 5 $\frac{1}{2}$	3,450	2 $\frac{3}{8}$	2 $\frac{3}{8}$	5M560
5 $\frac{1}{2}$ to 4	4,600	4 $\frac{1}{2}$	3 $\frac{3}{8}$	5M670
4 to 3	6,210	4 $\frac{1}{2}$	2 $\frac{1}{2}$	5M615
3 to 2 $\frac{1}{2}$	7,760	4 $\frac{1}{2}$	2	5M615

Diameter of Wheel	Wheel Speed R.P.M.	Pulley Motor	Pulley on Spindle	Belt Used
6 to 5	3,450	2 ³ / ₄	2 ³ / ₄	5M710
5 to 4	4,390	3 ¹ / ₂	2 ³ / ₄	5M710
4 to 3	5,330	4 ¹ / ₄	2 ³ / ₄	5M750
3 to 2	7,330	4 ¹ / ₄	2	5M750
2 to 1 ¹ / ₂	10,780	6 ¹ / ₄	2	5M800
1 ¹ / ₂ to ³ / ₄	14,380	6 ¹ / ₄	1 ¹ / ₂	5M775
³ / ₄ to ¹ / ₄	17,250	6 ¹ / ₄	1 ¹ / ₄	5M775

Diameter of Wheel	Wheel Speed R.P.M.	Pulley Motor	Pulley on Spindle	Belt Used
8 to 6 ¹ / ₂	2,840	3 ¹ / ₂	4 ¹ / ₄	5M775
6 ¹ / ₂ to 5 ¹ / ₂	3,450	2 ³ / ₄	2 ³ / ₄	5M710
5 ¹ / ₂ to 4 ¹ / ₂	4,190	4 ¹ / ₄	3 ¹ / ₂	5M775
4 ¹ / ₂ to 3 ¹ / ₂	5,330	4 ¹ / ₄	2 ³ / ₄	5M750

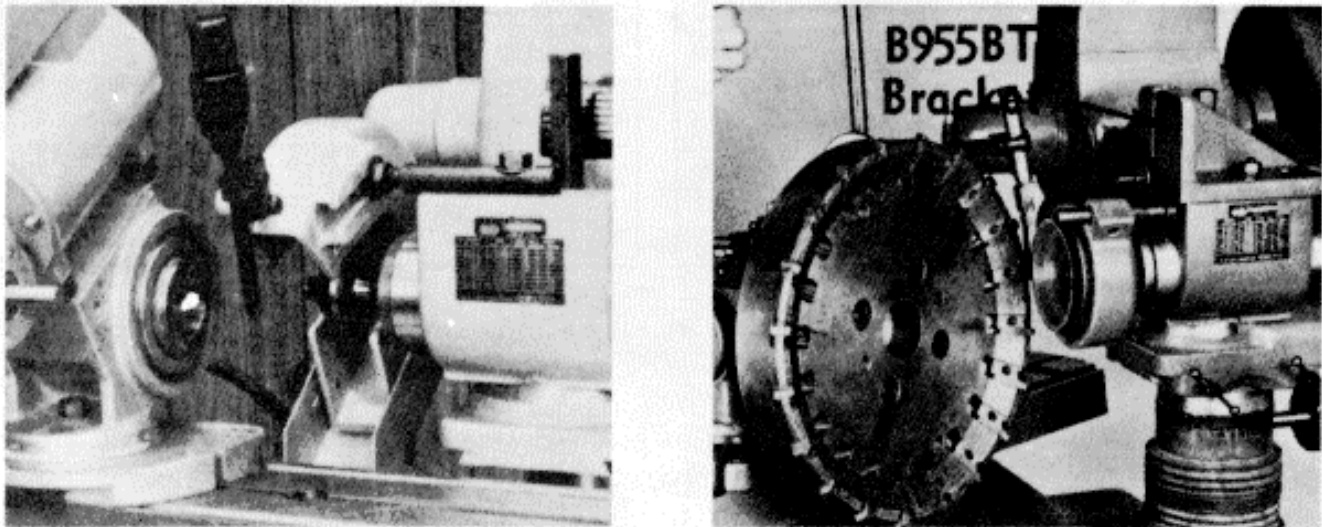
Other arbors shown in Photo 8 are the standard internal grinding arbors (B780J, B780K, and B780C) which are held in the left end of the spindle by an inner taper lock and threaded end. Tighten these arbors in place by using an open-end wrench while holding the spindle shaft with a wrench at the right end. The Y Inch and Y Inch threaded-shank mounted wheels screw into the B780J and B780K arbors. Y inch and Y4 Inch straight-shank mounted wheels fit into the collet assembly of the B780C arbor. Mount the straight-shank wheels as close as possible to the collet face. The straight shank should be seated into the collet at least 1/ inch.

- ii. Heavy Duty for Universal Grinders with the B955HD Head The 56055CL heavy duty cartridge spindle (Photo 9) has an operating speed range of 1,150 to 7760 R P.M. Mount the belt pulleys as shown in Photo 9 at the right side of the spindle. Mount the pulley first, then the keyed wheel flange and nut. Use the 8628 wrench to tighten the nut while holding the pulley by hand or holding the shaft stationary with the B936W spanner wrench The latter wrench holds either the collet itself (BY TWO REAR FACE HOLES) or its locking left-hand nut. The 936P wheel puller is used to extract wheel collets from the taper of the spindle. Remove the locking nut, screw on the puller to the collet, and then with the spindle held still, tighten the Inner thrust bolt with the spanner wrench end or other wrench Mount wheels to the B936CL wheel collets by first mounting the collet to the spindle tapered shaft. Clean the tapered surfaces, mount the collet, then the nut, and while holding the spindle with an open-end wrench at the spindle's right end, tighten the nut with the B936W wrench The body of the S894 wrench may be used as a lever in the U-shaped end of the spanner wrench. Once the collet body is locked to the spindle, remove the ring nut, keyed washer, and wheel spacer. Clean these items. Remount the wheels spacer which, when removed, allows for the mounting of 8 Inch by Y4 Inch wide wheels. Mount the wheel, the keyed washer, and the collet ring nut. Holding the spindle at the right end, tighten the collet nut with the B936W spanner wrench. See Part I of this section for safety precautions when wheels are being mounted.

- (e) Wheel Guards. For straight, cup, or saucer wheel grinding, with the

Instruction Manual**Section Four**

4, 6, or 8 inch dry guard the B955BT vertical T-slot bracket is used. The bracket is mounted to the spindle housing horizontal surface (SEE INSET). The wheel guard is mounted with the use of the accompanying wheel guard bracket (SEE INSET). Photo above shows

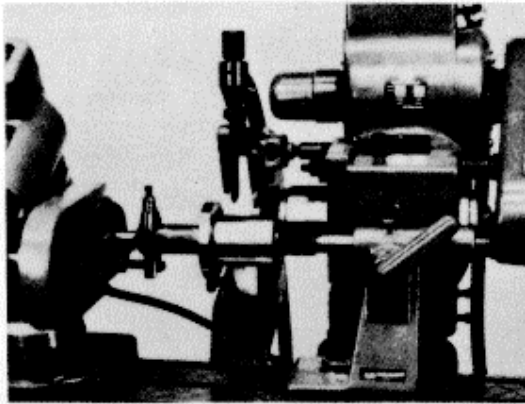


the B935CS wet wheel guard which is used with the B935 and B2035 coolant attachments. This guard handles wheels up to 7 Inches in diameter and attaches to B955 or B955HD grinding heads. Always keep B923CL motor shaft guard on unused shaft end as shown.

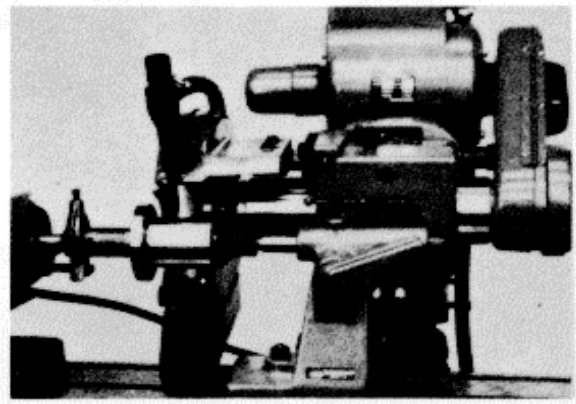
- (f) Wheelhead Speed Charts Follow the pulley and wheel size recommendations on the plate on the front of the grinding head. These combinations provide for safe wheel speeds while obtaining sufficient surface feet per minute. **WARNING:** Incorrect wheel speed for the size and type of wheel can cause dangerous wheel destruction B6055B and S6055CL Speed Charts for these models are listed on page 14.
3. **UNIVERSAL GRINDING HEADS FOR B6060 AND B6062 MODEL SERIES:**
- (a) Tilting Wheelhead: These universal heads differ slightly from those described in D-2(a) and (b), in that the bracket that constitutes the upper swivel in (3) Photo 4 has two other swivel brackets at right angles to its vertical faces, allowing the motor and spindle to "tilt" from the horizontal plane as much as 22 degrees either side of center. Socket screws (8) Photo 4 loosen the swivel, allowing the operator to tilt the spindle to the angle desired, as read from the dial at the top of the upper swivel bracket.
- (b) Spindle speeds, varied by changing V-belts and pulleys on the motor and spindle, are the same as described in D-2. The cartridge spindle locking screw is at (4) Photo 4 and this allows the spindle to be moved relative to its housing for alignment of the pulleys.
- (c) Swivels in the horizontal plane: The lower swivel is the cap for the column and constitutes the lower half of the dovetail slide. The hex socket nut for locking this swivel is located at (12) Photo 4. The upper swivel bracket rests on the dovetail slide and is held in place by hex nut (11) Photo 4 in the center hollow portion of the swivel. Both swivels have 360 degree calibration with an index marking point.
- (d) Dovetail Extension This slide is the same as described in D-2(c), located at (13) Photo 4.

Instruction Manual**Section Four**

- (e) Spindles, Pulleys, and Wheel Mounting:
- i. High-Speed for standard Universal Grinders with B6055 Head: The B6055A spindle (Photo 8) has normal speed range of 3,450 to 17,250 R P M. The B6055F pulley and wheel arbor has the same function as the one described In D-2(d), with the exception that it uses a face lock rather than a taper lock principle. I.D. arbors B6055J5, B6055JL, and B6055C have the same function as those described in D-2(d). While one of these arbors is being mounted on the spindle, the spindle is held at the right end by the B855W wrench applied to the flat portion of the shaft. Pulleys for this spindle lock on its tapered right end In the manner described In D-2(d) for heavy duty spindles.
 - ii. Heavy Duty for Universal Grinders with B6055HD Head: The B6062A heavy duty cartridge spindle (Photo 9) has an operating speed range of 2,840 to 5330 R P M. Mount wheels and pulleys in the same manner described in D-2(d) for heavy duty spindles. Note that the right-hand pulley may be either a plain V-pulley or the B936CV Collet and Pulley, but in either case these pulleys employ a taper lock onto the spindle shaft.



B6035 Coolant System



B6035HD Heavy Duty Coolant System

- (f) Wheel Guards: Guards for wheels of 4, 6 or 8 Inch diameter are mounted with the use of the accompanying bracket to the left vertical surface of the spindle bracket. A drilled and tapped hole is provided at the right side of the spindle bracket for mounting the same guards when a wheel is mounted on the B936CV wheel collet The Inset shows the 86035 coolant system with B935GS 7 Inch wet wheel coolant guard adapted to the B6060 grinder series The B6035HD heavy duty coolant with B6035G wet wheel guard is used on the B6062 series with 8 inch diameter wheels Always keep B923CL motor shaft guard on unused shaft end.
- (e) B6055A and B6062A Speed Charts for these models are listed on page 15.

E. Swivel Table Adjustments for Taper and Clearance:

1. All machines have an upper work table known as a swivel table (20) Photo 5. Its primary function is to allow tapers to be ground on a variety of tools and work pieces The table is freed for adjustment by loosening the two

Instruction Manual**Section Four**

clamp bar socket screws (9) located at the right end of the table Use the swivel table adjustment screws (8) to align it with the sub-table. When the pointer (11) mark aligns with the 0 line on the index plate (10), the two tables are aligned If greater accuracy than a sight scale is needed, use a test arbor between tallstocks in conjunction with a dial Indicator to measure exact taper in inches per foot. The index plate is calibrated in inches per foot up to 3 inches either side of center.

2. The swivel table is also used for setting clearance angles on cutters which have been mounted by various means on the table. The Index plate is calibrated up to 15 degrees either side of center. For large clearance angles, or when additional distance between the work and the wheel is needed, the swivel table may be pivoted on its central hub so as to cause its ends to leave the bed rests on the subtable. The center hub is calibrated 360 degrees and utilizes two friction socket screws (12) Photo 5 which may be tightened for additional stability when the clamp bar cannot be used.

F Tailstocks and Workheads'

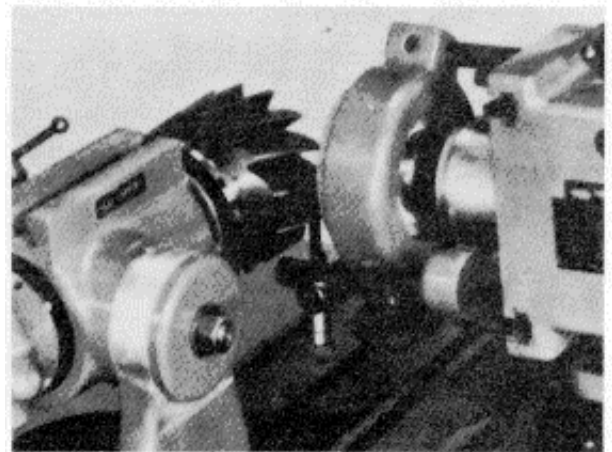
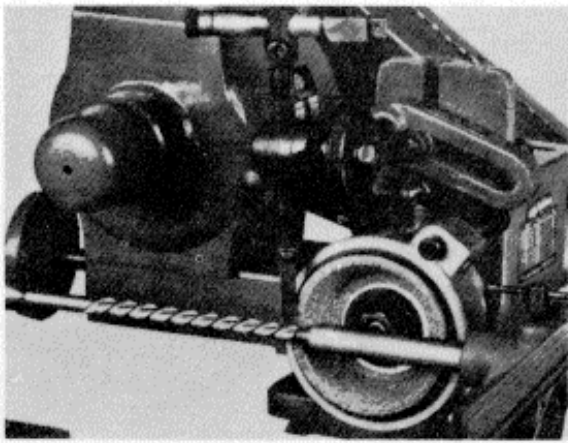
1. Tailstocks are used to hold cutters and other work which must be mounted on straight arbors. With the exception of the B6060 and B6062 series grinders, all machines have tailstocks with centers at a height of 4.130 inches above the swivel table The former models have a height of 6.130 inches above the swivel table. Tailstock centers (RIGHT AND LEFT) on both of the B922 and B6022 sets are interchangeable. Each center's flat side may be faced in either of four positions-up, down, front, or rear, when the handle locking screw (21) Photo 5 is loosened sufficiently. The right-hand tailstock has a tension adjustment threaded plunger (15) which is adjustable by hand. Lever (16) is used to retract the right-hand center from the work during loading and removal of work between the centers.
2. Before mounting the tailstocks to the table, clean the table and check for any table surface roughness that might affect the bedding of the stocks to the table The tailstocks are mounted to the grinder table by keeping the special T-slot bolts loose and sliding the head of each bolt into the table T-slot (FROM THE CENTER OR END OF THE TABLE), while still attached to the tailstock Position the tailstocks to the desired location and align the bases to the table by tightening the clamp bar assembly at the front base of each with the hex socket screw (13) Be sure that the T-slot blocks of each tailstock drop into the grinder table slot Finally, tighten the nut on each T-slot bolt, thus locking the tailstocks firmly to the work table
3. Workheads (NOT STANDARD EQUIPMENT) are mounted to the table in the same manner as tailstocks Their base plates must be aligned with the work table before tightened down with T-slot bolts. Most workheads have swivel elements which allow the spindle axis to be rotated In the horizontal and vertical planes All swivels are calibrated in degrees with an 0 index mark reading.

G Using Diamond and Wheel Dressers to True and Dress the Wheel.

1. The B640K and B6040K diamond dressers (see standard equipment, pages 96, 97, 99) contain a diamond nib which may be rotated periodically In its column mounting. The dresser mounts to the table with a T-slot bolt. Observe the following steps when the dresser is to be used.

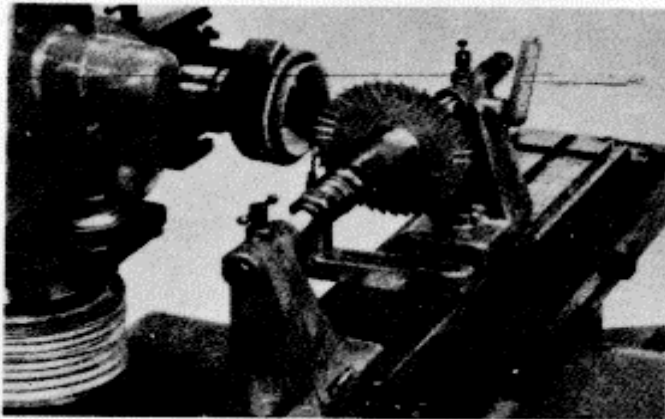
Instruction Manual**Section Four**

- (a) Lower the wheelhead so that the spindle shaft center is slightly above the diamond point.
- (b) Slant the axis of the nib at an angle of about 15 degrees from perpendicular to the wheel to be dressed.
- (c) Using the crossfeed to advance the diamond to the wheel, traverse the diamond across the face of the wheel, using the table handwheel, with transmission in low ratio. Truing the wheel, a process that makes the periphery run concentric to the spindle shaft, is accomplished by taking cuts into the wheel of no more than .001 inch per pass. Truing is usually confined to straight wheels on tool and cutter grinders. Dressing passes are very light, with the table speed varied depending on how "open" the operator wishes to leave the wheel
- (d) Dressing is a process of restoring the cutting sharpness of the wheel, and, while it may employ the use of the diamond dresser on occasion, this can also be accomplished with a 'dressing stick' or a mechanical rotary truing device such as the K O Lee abrasive wheel dresser. When a dresser such as the EI is tilted slightly to one side and allowed to run against a rotating wheel, it will remove slight run-out quickly and restore cutting sharpness by its cleaning action. The E1 can also be used to form wheel edges and special shapes.

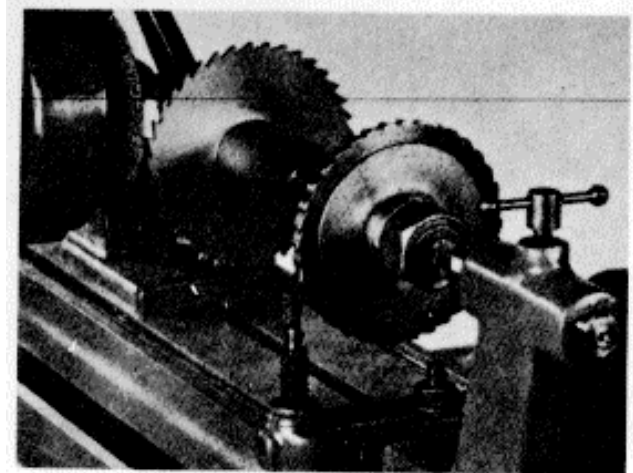


H. Toothrests and Height Gauges:

1. The insets show the BA940 and B6040 Universal Toothrests set at typical locations on tool and cutter grinders and on universal grinders. Note that only the B6040 toothrest used on tilting wheel head grinders can be placed on the wheelhead with blade from below the wheel, for purposes of grinding down at the point of contact with the cutter. Universal toothrests may also be placed on the grinder table or workheads as shown in photos in Section Five. This mechanism, with a spring-loaded rocker, is used to "roll" a cutter about its mounting axis for clearance angle settings when the rest is placed directly on cutter teeth. The short micrometer rigid toothrest (B940H) is used in the same manner where the cutter is moved away from the rest when indexing to the next tooth. Consult Section Five, Chapter 1 for discussion of toothrest positions.
2. The B827 and B6027 plain (MICROMETER) toothrests are placed on the grinder table and usually used in conjunction with an index disc on a



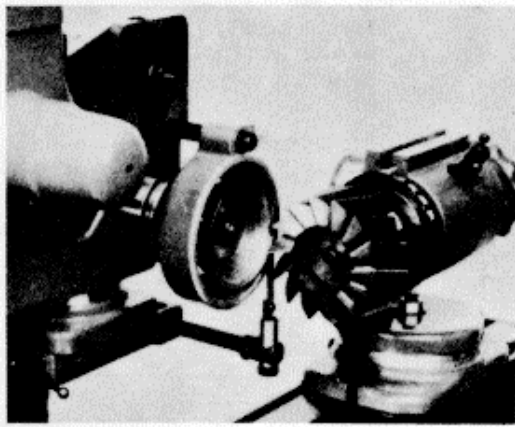
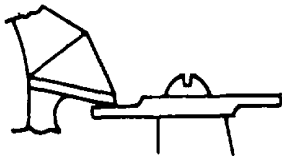
B827 Plain Micrometer Toothrest



B6027 Plain Micrometer Toothrest

straight arbor, shown in the inset. They may also be used to Index cutter teeth directly. They have a micrometer extendable barrel assembly to hold various blades.

- Height gauges B939 and B6039 are used to set the wheel spindle axis at the same height as the centers of tallstocks or workheads. They are also employed for putting the face of a cutter tooth to be ground at the height above the table as the cutter's center. Use the inside of the "V" portion of the cast sliding pointer for locating the center of work without center holes. The diamond shaped pointer plate has two surfaces (ONE ON TOP, ONE ON THE BOTTOM-SEE INSET) which are exactly at the same height in a horizontal plane. This is for the purpose of quickly setting the toothrests relative to a cutter tooth. Consult Section Five, Chapters 1 and 3 for this procedure.



B955PC Dovetail Clamp, standard with all universal models, is shown mounted on Dovetail Slide. Arm and B940H Micrometer Tooth Rest (parts of BA940 Universal Tooth Rest) are extended from the B955PC for this setup, which allows cutters to be ground with wheel rotating down-ward, by placing teeth faces onto tooth rest in this position.

Instruction Manual
Section Five

**CUTTER GRINDING AND
OTHER TOOL GRINDER OPERATIONS**

CHAPTER 1

**Introduction to Sharpening High-Speed Steel
and Cast Alloy Multi-Tooth Cutters**

In general, it may be said that the working efficiency of a cutter is largely determined by the keenness of its cutting edges. Consequently, it is important to sharpen a cutter at the first signs of dullness. Not only does a dull cutter leave a poorly finished surface, but also the continued use of such a cutter leaves it in a condition necessitating the grinding away of a considerable portion of the teeth to restore the cutting edges. When the cutter is maintained in good working condition by frequent sharpening, it is certain to be cutting rapidly and effectively at all times. Furthermore, when such a cutter does need resharpening, it is necessary to grind the teeth only a very small amount to restore its keen cutting edges.

Cutters and reamers are usually ground on tool and cutter grinding machines. The universal type of cutter grinder, as the name implies, can be set up for a variety of grinding operations, including light cylindrical, surface and internal grinding, as well as for sharpening cutters of all kinds.

I. GRINDING WHEELS RECOMMENDED

The grade of a standard grinding wheel used for sharpening cutters must be in the soft range to insure a free cutting action and to avoid drawing the temper of the cutting edge. At the same time, if the wheel is too soft, its rapid wear makes it difficult to keep the cutter a true cylinder or to produce a keen edge.

In general, for most tool grinding work, an aluminum oxide (46 or 60 GRIT), medium soft grade (J-L), structure spacing number 5 to 8, vitrified bonded wheel (ALLOWS 4,500 to 6,500 s f p m) is recommended in various shapes. wheels that fall in this range are Cup- CV4NH60, CV4NM60; Saucer - SV6GH60, SV6GM60; Straight or Plain -PV6GH60, PV5FH60, PV7GM60, PV8GM60 Wheel marking, from left to right: first letter-shape of wheel; second letter-bond type; next number-size of wheel O D, third letter-wheel hole size; fourth letter-wheel thickness, last number-grit size.

When grinding carbide cutters, it is advisable to use a diamond cup wheel, although Silicon Carbide wheels may be successfully used where wheel wear is not a large factor in holding size. Example of this type of wheel is the RV6NH100 recessed straight wheel used with the B945 Tilting Table Attachment.

Where desired, newer types of wheels, such as those made from cubic boron nitride, may improve results on high-speed steel cutters. They give a grinding action comparable to diamond wheels and do not break down as quickly as aluminum oxide wheels.

Cylindrical grinding can be accomplished with the above straight wheels. Generally, even for relatively soft steels, wheel grades approaching "L" or "K" and structure spacing near number 8 will be found desirable. If desired results are not obtained with the standard wheel, try wheels which approximate these specifications having the same material composition. With soft steel, the grit may be dropped to 54.

Instruction Manual

Section Five

for best results. The main factors to be considered are the material being ground, size of work, amount of stock to be removed, and the finish desired. The harder the material, the softer the wheel required. The larger the work diameter, the coarser and softer the wheel. The amount of stock removal and the finish will determine the grain size economical for the job. Light feed of the material to the wheel permits the use of finer and softer wheels.

For sharpening Fellows Gear Shaper cutters, slightly finer grit wheels, approximately 80 grit, should be used. A complete list of wheels to use for sharpening various types of cutters is not included, as many handbooks listing complete grinding wheel recommendations are available from the manufacturer.

Dry grinding is generally recommended for most high-speed steel cutter sharpening operations because experience has shown that satisfactory results are readily obtained in this way, and the operations are such that wet grinding causes inconvenience to the operator. When wet grinding, use sufficient supply of coolant to keep the work from overheating. In wet cylindrical grinding, slightly harder wheels may be used.

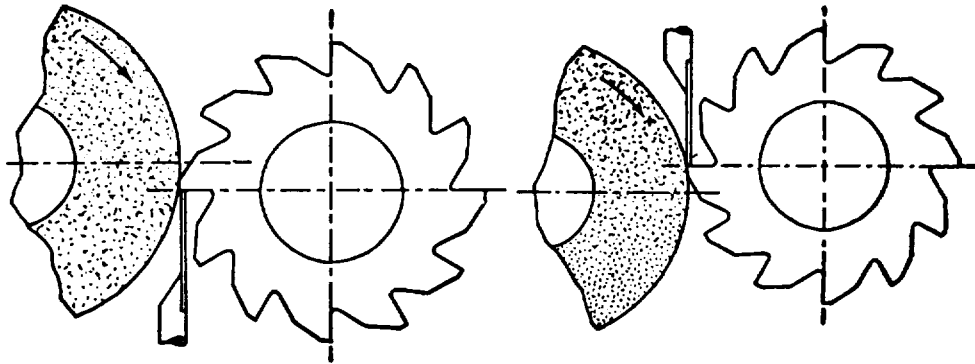


Figure 11.-Showing method of grinding with wheel rotating off cutting edge.

Figure 12.-Showing method of grinding with wheel rotating onto cutting edge.

II. DIRECTION OF WHEEL ROTATION

Cutters and reamers may be ground with the grinding wheel rotation either off or toward the cutting edge as shown in Figures 11 and 12.

If the wheel is run off or away from the cutting edge as shown in Figure 11, the wheel holds the cutter against the toothrest. As this is the safer method, it is more commonly used. This setup may be reversed, if so desired, cutting edge facing up, toothrest pointing down, and wheel running counterclockwise. It has the objection, however, of throwing up a burr on the cutting edge of the tooth which should be oilstoned off. Furthermore, there is some danger of burning the tooth at the cutting edge.

If the cutter is ground by rotating the wheel onto the cutting edge as shown in Figure 12, there is less tendency to burn the tooth, and a keener cutting edge, free from burr, is possible. Care must be taken, however, to hold the cutter firmly against the toothrest, as otherwise the rotation of the wheel will carry the tooth into the wheel and cause it to be ground away.

While straight wheels are shown in Figures 11 and 12, the same comments regarding direction of grinding wheel rotation apply to the use of cup wheels.

Instruction Manual
Section Five

III. RELIEF ANGLE (CLEARANCE)

A. Relief Angle:

Relief may be defined as the amount of stock removed from the teeth behind the cutting edge to permit the teeth to cut freely and to clear the material after the cutting edge has done its work.

It is important that the relief angle be correct. If it is insufficient, the teeth will have a dragging cut, while if it is too great, the teeth will wear rapidly and the cutter is likely to chatter. Too much relief, however, is less objectionable than too little, as under the former condition, the cutter will function, while under the latter, it may not cut accurately.

The proper relief angle depends upon a number of factors, principally the type and diameter of the cutter and the hardness of the material to be machined. For example, cutters employed on soft materials like brass can stand more relief than those employed on steel or cast iron. Likewise, the relief must be greater for small cutters than for large ones. For these reasons, it is generally agreed that the correct relief angle for a given cutter must be determined by experience. Once the relief angle (AS WELL AS CUTTING SPEED AND FEED) that gives the best results on a certain operation has been determined, it should be recorded for future reference.

The general ranges of relief angles for typical tools and work materials are shown in the table below.

Cutter	Tool Material	Work Material		
		Steel	Iron	Nonferrous and Nonmetallics
Peripheral or O.D. Cutting Edge	High Speed Steel	5° to 10°	5° to 10°	7° to 12°
	Cast Alloy	4° to 6°	4° to 6°	5° to 10°
	Cemented Carbides	4° to 6°	4° to 6°	5° to 10°
Side or End Cutting Edges	All	1° to 4°	1° to 4°	2° to 7°

*Smaller diameter cutters required larger relief angles.

B. Width of Land:

The land, which is the narrow surface immediately behind the cutting edge that is ground to the relief angle, should be about 1/32 inch to 1/16 inch wide, depending upon the type and size of the cutter. As a result of repeated grinding, the land may become so wide as to cause the heel of the tooth to drag on the work. To control the width of the land, a clearance or secondary angle, usually double the relief or primary angle, is ground as shown in Figure 13.

Relief on New Cutter



Figure 13.-Width of land increases with repeated sharpenings, causing interference at A. Grind clearance angle as shown by dotted line to control width of land.

Instruction Manual
Section Five

The relief on the end teeth of end mills should be about 3 degrees to 5 degrees. On formed milling cutters or involute gear cutters, relief does not have to be considered in resharpening because the teeth are so formed that when they are ground radially on the face, the relief remains the same.

C. Determining the Relief Angle:

The relief angle is determined by the setting of the grinding wheel, the cutter and the tooth rest. Either a straight wheel or a cup wheel may be used. If the lands on the cutter teeth are narrow, a straight wheel is frequently used. If the lands are wide, a cup wheel should be used. See Figure 14. It is possible to use a straight wheel on wide lands by swiveling the wheel head about 1 degree from the zero line so that the cut approaches a straight line.

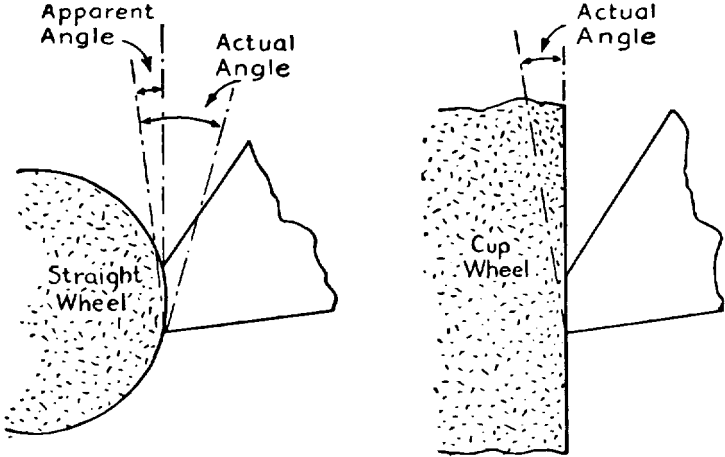


Figure 14.-Showing effect of wheel shape on relief angle.

The general procedure in determining the setting for the relief angle is to bring the center of the wheel and the work, as well as the end of the toothrest blade, all on the same plane, and then to raise or lower the wheelhead the proper distance to give the desired relief angle. When a straight wheel is used, this distance varies with the diameter of the wheel. When a cup wheel is used, the distance varies with the diameter of the cutter.

On the B6060 and B6062 series cutter grinding machines, the tilting wheelhead unit is provided with a dial graduated in degrees for quickly setting the angle of a cup wheel face to the exact relief angle desired. With this feature, when a cup wheel is used, it is not necessary to go through the procedure of bringing the center of the wheel and the work onto exactly the same horizontal plane. After tilting the wheelhead to the desired degree, simply adjust the toothrest to the same height as the center of the work (BY MICROMETER, OR SMALL MOVEMENT OF WHEELHEAD). The toothrest may be located on the wheelhead or the table, depending on the nature of the setup. If this tilting feature is not available, the toothrest setting for the relief angle must be obtained either from the tables, pages 104-108, or by the following methods and calculations.

Instruction Manual
Section Five

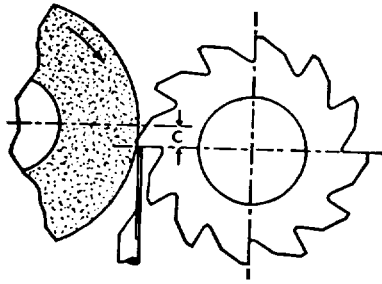


Figure 15.-Developing the relief angle when using a straight wheel

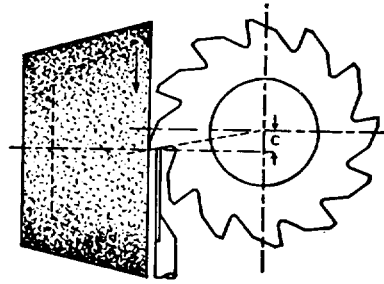


Figure 16.-Developing the relief angle when using a cup wheel.

1. **Setting the Toothrest, Using a Straight Wheel** (SEE TABLE I, PAGE 104, FOR CLEARANCE ANGLE SETTING.)

Figure 15 illustrates a milling cutter being ground with a straight wheel. The distance C between the center lines of the wheel and cutter varies with the relief angle. The method of producing the desired relief angle, when using a straight wheel, is as follows:

- (a) Bring the center of the wheel and the work onto the same plane.
- (b) Fasten the toothrest to the table of the machine and adjust the toothrest to the same height as the center of the work, using a height gauge.
- (c) Raise (or lower, depending upon the direction of wheel rotation) the wheelhead the proper distance by means of the graduated hand wheel. The distance to raise or lower the wheelhead when using a straight wheel may be calculated as follows: Multiply the relief angle in degrees by the diameter of the wheel in inches, and this product by the constant .0087.

Sample solution for determining the distance to raise or lower the wheelhead for a 7 degree relief angle, using a straight wheel 6 inches diameter: $C = 7 \text{ degrees} \times 6 \text{ inches} \times .0087 = .365 \text{ inches}$.

2. **Setting the Toothrest, Using a Cup Wheel, (NON-TILTHEAD GRINDERS):** (SEE TABLE II, PAGE 105, FOR CLEARANCE ANGLE CHART SETTINGS)

Figure 16 shows a cup wheel being used for sharpening a cutter. The procedure for producing the desired relief angle of a spiral milling cutter, for example, is obtained as follows:

- (a) Fasten the toothrest to the wheelhead and align the toothrest and center of the cutter on the same plane, using a height gauge.
- (b) Raise or lower the wheelhead with the toothrest the required distance. To calculate the distance when using a cup wheel, multiply the required relief angle by the diameter of the cutter in inches and this product by the constant 0087.

Sample solution for determining the distance to raise or lower the wheelhead beyond the center of a cutter 3 inches in diameter, in order to produce a relief angle of 5 degrees using a cup wheel 4 inches in diameter: $C = 5 \text{ degrees} \times 3 \text{ inches} \times .0087 = .130 \text{ inches}$.

Instruction Manual

Section Five

NOTE: If the cutter grinder is equipped with a tilting wheelhead, this is simply set to the desired relief angle, as read on the machine scale, but the toothrest blade end and the center of the cutter are left on the same plane.

IV. TYPICAL SET-UPS FOR SHARPENING CUTTERS

To give the reader a general idea of the methods commonly employed in the setting up and sharpening of cutters, the following pages give a number of typical cutters together with brief descriptions of the grinding procedures employed in each case. Unless otherwise specified, a cup wheel is assumed for all set-ups.

From the standpoint of design and method of sharpening, cutters may be classified into two general groups.

A. The first consists of cutters which are sharpened on the periphery or sides, by grinding the relief angle behind the cutting edge of the tooth. Included in this group are plain milling cutters (STRAIGHT AND HELICAL TEETH), staggered tooth cutters, side milling cutters, face milling cutters, end mills, angular cutters, slitting saws, and reamers.

1. PLAIN (HELICAL) MILLING CUTTERS (SEE PAGE 36 FOR ILLUSTRATION AND DESCRIPTION OF TYPICAL SET-UP.)

The cutter is mounted on an arbor which is supported between centers and set sufficiently below the center of the wheel spindle to produce the desired relief. On tilting wheelhead cutter grinders, the wheelhead equipped with cup wheel, is tilted the desired amount of relief in degrees.

The toothrest must be mounted on the wheelhead and adjusted so that it has a complete bearing on the tooth to be ground at the point of grinding contact. With the cutter held against the toothrest by light hand pressure, the cutter is traversed across the wheel face, either by moving the table or by sliding the cutter on a cutter bar. For safety and accuracy, we recommend mounting the cutter in a fixed position on an arbor, moving the cutter relative to the wheel by means of table traverse.

In sharpening any type of plain milling cutter, the greatest difficulty lies in keeping the peripheral cutting edges radially equal. A cutter out of truth cuts with a constant pounding action. If the wheel wear during the sharpening operation is equalized, it follows that the cutter is kept cylindrical. This equalization is achieved by grinding around the entire cutter, then revolving it 180 degrees, starting anew on a tooth just opposite the original starting point, taking another light cut all the way around the cutter. This method is repeated, taking light cuts until the cutter has been sharpened sufficiently.

A straight wheel can also be used for grinding plain cutters. A cup wheel, however, has the advantage of producing a straight angle or relief back of the cutting edge. To prevent the opposite side of the cup wheel from striking the cutter, the wheelhead should be swiveled slightly from the zero line in the horizontal plane.

Some tool rooms have found that cutters for use on steel and cast iron will cut with less chatter and stand up longer between regrinds if they are first ground cylindrically and then backed off to leave a land from .005" to .010" wide at the cutting edge.

Instruction Manual
Section Five

2. STAGGERED TOOTH MILLING CUTTERS (SEE PAGE 41 FOR ILLUSTRATION AND DESCRIPTION OF A TYPICAL SET-UP.)

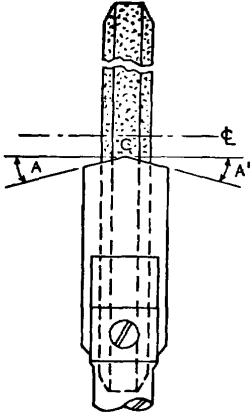


Figure 17.-Shape of blade of tooth rest for sharpening staggered tooth milling cutters.

having alternately right and left-hand spiral teeth may be sharpened at one setup by using a toothrest with the top of the blade either rounded or shaped with a double angle (INVERTED V). The operation is similar to grinding a plain spiral mill, with the cutter mounted on an arbor between centers and the toothrest fastened to the wheelhead. Relief may be generated directly by tilting the wheelhead as in III-C above.

The blade of the special toothrest shown in Figure 17 is ground to coincide with the right and left spiral angles of the cutter teeth. The high point (c) of the toothrest must be located in the center of the cutting edge (FACE) of the wheel. The wheelhead is raised sufficiently to give the desired relief.

The cutter is traversed across the wheel with the spiral edge of the toother resting on the corresponding edge of the toothrest. In grinding the next tooth, having the alternate spiral, the cutter is traversed in the opposite direction, using the other edge of the toothrest. Best results will be obtained if the face of either the straight wheel or cup wheel is beveled to about 1/8 inch wide at the periphery, or the cutting edge.

Staggered tooth milling cutters,

3. SIDE MILLING CUTTERS (SEE PAGE 40 FOR ILLUSTRATION AND DESCRIPTION OF A TYPICAL SET-UP.)

The cutter is mounted on a stub arbor and locked into the self-locking taper in the universal workhead. The cutter may also be mounted on a straight arbor and held between centers. The toothrest is usually fastened to the workhead or table.

While the setup illustrated shows the use of a cup wheel and tilting wheelhead, a straight wheel can also be used, in which case the cutter arbor is set in a horizontal position and the wheelhead raised, or lowered, to produce the required side tooth relief. The peripheral teeth of side milling cutters are sharpened in exactly the same manner as previously described for plain cutters. If the cutter is helical, the toothrest assembly is mounted on the wheelhead.

4. FACE MILLING CUTTERS (SEE PAGE 43 FOR ILLUSTRATION AND DESCRIPTION OF A SPECIFIC SET-UP.)

Special machines of suitably heavy construction are available for sharpening large face milling cutters. However, if they are not too large, they can be sharpened on a universal tool and cutter grinder. They should be mounted on a tapered shank supported in the workhead spindle in the same manner as they are supported on the milling machine. The operations involved in sharpening a face milling cutter are similar to those in sharpening a shell end mill and include grinding the periphery, face, and corners of the blades. For cast iron, the peripheral relief angle should be about 4 degrees; for soft steel, about 6 degrees. A secondary clearance may be ground to leave a land 1/16 inch to 3/32 inch wide.

Instruction Manual

Section Five

The same relief angles are used for the face edges which, for rough milling, should have a land about 3/8 inch wide, with the remaining portion of the edge ground off at an angle of about 3 degrees toward the center of the cutter. Finish milling is a thin shearing operation, and for best results, the face of the cutter should be ground off at an angle of 1 degree to 2 degrees to give it a slight lead into the work. The corners of the blades are usually ground at 45 degrees bevel by swiveling the workhead or table, and are left 1/16 inch to 1/8 inch wide.

After grinding, the cutter should be carefully checked on the face with a dial indicator. If the cutter has been properly ground, taking light finishing cuts of not more than one half thousandth inch per pass, tooth height should be uniform.

5. **END MILLS** (SEE PAGE 38 FOR ILLUSTRATION AND DESCRIPTION OF A SPECIFIC SET-UP. SEE CHAPTER 14, PART V, PAGE 92 FOR DESCRIPTION OF END MILL GRINDING WITH AN AIR-BEARING WORKHEAD)

End mills with shanks are supported in the universal workhead or in the combination attachment, and are ground with the same spiral action as described for plain milling cutters. If the end mill is the shell type, it must first be mounted on a suitable arbor. In sharpening the end teeth, the workhead is usually swiveled horizontally about one-half degree from the zero line so as to grind the teeth slightly low in the center of the mill and thus prevent dragging. The workhead is then swiveled in the vertical plane to give the desired relief (OR THE WHEELHEAD IS TILTED).

6. **ANGULAR CUTTERS** (SEE PAGE 42 FOR ILLUSTRATION AND DESCRIPTION OF A SPECIFIC SET-UP)

An angular cutter may be considered as made up of a number of plain milling cutters of different diameters. When any cutter with a cup wheel is ground on a conventional tool and cutter grinder, the relief angle is determined from the diameter of the cutter. It follows that this method would lead to difficulties when applied to angular cutters because of the variation in the diameter of the cutter along the cutting edge. For this reason, the 0 D of a saucer wheel is commonly used.

On a tilthead cutter grinder, a cup wheel can be used without need of "trial and error" tactics, and the relief angle is constant for the full tooth length.

On all non-tilthead grinders, the cutter is mounted on an arbor and supported in a universal workhead, which is then swiveled to the angle of the cutter. It may also be mounted between centers on an arbor, with table swiveled. The toothrest is fastened to the swivel table or wheelhead and adjusted against the tooth to be ground, on center with the cutter. The wheelhead is then raised or lowered (OR MICROMETER ADJUSTED) to give the desired relief. The cutter is held against the toothrest by hand as it is traversed against the wheel edge. Chapter 7 of Section Five discusses the set up when using a saucer wheel to generate a constant clearance angle.

7. **METAL CUTTING SAWS** (SEE PAGE 84 FOR ILLUSTRATION AND DESCRIPTION OF A SPECIFIC SET-UP.)

Small saws are ground in essentially the same manner as milling cutters - usually with a 5 degree relief angle. On very small saws, the angle may

Instruction Manual

Section Five

advantageously be increased to about 7 degrees while on larger saws, around 10 inches in diameter, for example, it should be reduced to about 3 degrees. To minimize the effect of wheel wear, a light finishing cut should be taken completely around the saw.

Except in the case of very small saws, the same grit and grade of cutting wheels may be used as for sharpening milling cutters.

While a straight wheel or a cup wheel can be used, some machinists prefer to grind these saws with the narrow periphery of a dish wheel to avoid overheating and possibly burning the teeth. For certain smaller saws, a straight wheel formed to a "V" of approximately 60 degrees will suffice not only to create the proper rake (IF ANY) on the teeth, but also to produce a sharp cutting edge while maintaining necessary flute depth and secondary clearance for all teeth in succession. Small saws may be ganged. Large metal cutting saws are generally sharpened on special, automatic saw sharpeners. If such a machine is not available, the saws can still be sharpened on a tool and cutter grinder with the aid of a special fixture, such as the B988 illustrated on page 102. In this case, they are mounted horizontally with special stiffening plates and toothrest to index on the tooth being ground. In the case of high-speed steel saws, to offset the effect of wheel wear, divide the saw into quarters and start grinding on a new quarter with each complete rotation of the saw.

8 CHUCKING REAMERS (SEE PAGE 67 FOR ILLUSTRATION AND DESCRIPTION OF A SPECIFIC SET-UP.)

There appears to be no standard method of sharpening reamers. In the case of machine or chucking reamers of the solid type, the size obviously is lost as soon as the periphery is touched with a grinding wheel. In as much as most of the cutting is done by the entering corners of the blades, it is common practice to sharpen such reamers by simply grinding the lead or front bevel, usually at an angle of 45 degrees.

When the straight cutting edges become dull to the point of requiring sharpening, the reamer is ground cylindrically to the next smaller size. The cutting edges are then "backed off", leaving a primary land from a few thousandths to about 1/32 inch wide depending upon the material being reamed and the size of the reamer. The reamer will be found to cut better if it is left with a back taper of about .0005 inch per inch sloped down to the shank.

Before resharpening chucking reamers of the expansion or adjustable type are adjusted outward a small amount. They are then ground cylindrically with a straight wheel to the exact size desired, with the reamer supported between centers. The cutting edges are then "backed off" in a conventional manner for milling cutters, leaving a primary land (MARGIN) of the proper width for the material being reamed.

For steel, the best results are generally obtained with a primary land from .005 inch to .008 inch wide. For cast iron, a slightly wider land, about 1/64" inch, may be used. For nonferrous metals like brass and soft bronze, the land should be reduced to a "white line", no more than .002 inch wide.

9. HAND REAMERS (SEE PAGES 65-67 FOR ILLUSTRATION AND DESCRIPTION OF A SPECIFIC SET-UP)

Except in the smaller sizes, the majority of hand reamers in use today are of the expansion or adjustable type. The usual procedure in sharpening such a reamer is to "set out" the blades a sufficient amount, grind it

Instruction Manual

Section Five

cylindrically to the exact size desired, and then "back off" the teeth so as to leave practically a sharp cutting edge, the land being no more than a few thousandths of an inch wide. A few light strokes along the cutting edges (FACES) with an oilstone will remove any slight burr produced in grinding.

If the reamer is provided with a front pilot and is ground between centers, the center supporting the expansion plug end should be adjustable so that the pilot surface can be centered with an indicator before grinding.

Hand reamers are always ground with a taper or lead at the front portion of the blades to allow it to enter the hole freely and without chattering. The amount of lead depends on the amount of material to be removed and is generally about 1/16 inch per foot (OBTAINED BY ADJUSTING THE SWIVEL TABLE OF THE GRINDING MACHINE) and approximately 1/2 inch in length for reamers up to 2 inches in diameter, and 3/4 inch in length for larger sizes.

10 TAPER REAMERS (SEE PAGE 67 FOR ILLUSTRATION AND DESCRIPTION OF A SPECIFIC SET-UP.)

Taper reamers must be ground with great care in order to maintain the correct taper and the diameter. The toothrest is fastened to the wheelhead and the finger is adjusted to support the tooth being ground. The swivel table is adjusted to the required taper per foot, as indicated on the graduated scale at the end of the grinder table.

The relief angle will depend on the material to be cut and the size of the reamer. Tables for relief of reamers are given in Section Seven of the manual and should be taken as only approximations for most reamers. On the tilting wheelhead cutter grinder, the relief setting is made by simply tipping the wheelhead to the angle desired. Trial cuts should be taken with a sharpened taper reamer, and the reamer hole tested for truth with a standard plug before using the reamer.

In some tool rooms, taper reamers are sharpened by grinding cylindrically and then "backing off" the teeth, leaving a land a few thousandths of an inch wide, as in grinding straight reamers. This method insures uniform tooth height, which is important if the reamer is to cut without chattering and leave a smooth finish.

B. The second general group consists of cutters which are sharpened by grinding the front, radial cutting faces of the teeth so as not to alter their profile. This group includes formed cutters, Fellows, and involute gear cutters, hobs, and forming tools.

1. FORMED CUTTERS (SEE PAGE 48 FOR ILLUSTRATION AND DESCRIPTION OF A SPECIFIC SET-UP)

Formed cutters are ground radially on the cutting face with a saucer wheel. Various methods are employed for controlling the spacing of the teeth. For most set-ups, the cutter is revolved until the face of a tooth just touches the cutting face of the grinding wheel. Previously, the wheel face and the center of the radial tooth cutter must have been brought into the same vertical plane. The toothrest is then adjusted against the back of the tooth to be ground.

Some form cutters are made with a forward rake or undercut tooth. In sharpening these, care must be taken to offset the wheel face so as to maintain the original rake angle. The amount of this offset, measured on

Instruction Manual

Section Five

a horizontal plane, is usually stamped on the cutter in thousandths of an inch.

The cutter is passed across the wheel face with a steady motion, using the hand traverse. During the grinding, the crossfeed must not be changed as this would change the radial line of the cutter face. Instead, the cutter is given a slight forward rotation toward the wheel by slightly advancing the micrometer toothrest. If the cutter is badly worn and there is much grinding to be done, compensation for wheel wear can be made by resetting the wheel radially just previous to a light finishing cut. To insure correct spacing of the teeth using this method, it is advisable to first grind the backs of the teeth, especially on a new cutter.

2. FELLOWS GEAR SHAPER CUTTERS (SEE PAGE 53 FOR ILLUSTRATION AND DESCRIPTION OF A SPECIFIC SET-UP.)

The cutter is supported on a face plate and tapered stud mounted in the universal workhead which is swiveled horizontally to an angle of 5 degrees, representing the rake of the cutter. After grinding, the accuracy of the cutter angle should be checked with a gauge to be sure it is exactly 5 degrees.

3. HOBBS (SEE PAGE 51 FOR ILLUSTRATION AND DESCRIPTION OF A SPECIFIC SET-UP.)

Like formed cutters, the teeth of hobs are made with uniform relief and are sharpened by grinding radially on the faces of the teeth, using the beveled side of a saucer wheel, or a "B" face straight wheel. See wheel shapes, page 110. The most important precaution to be observed in setting up for this operation is to line up the cutting face of the wheel with the center of the hob. Also, after each cut, the hob should be revolved toward the wheel for taking additional cuts, and not adjusted to the wheel by means of the machine crossfeed.

In the actual sharpening operation, whether it is done on a tool and cutter grinding machine or on a special hob grinder provided with automatic work spindle indexing arrangement, care must be taken to remove the same amount of stock from each tooth. It can readily be seen that if some teeth are ground back more than others, those which are left high will have all the work to do, resulting in irregular cutting action which will affect the accuracy and finish of the teeth produced.

Hobs of average size are ground successfully with standard cutter sharpening wheels, usually saucer shaped. For larger hobs, wheels which are of slightly less friable aluminum oxide are recommended

4. FORMING TOOLS (SEE PACE 92 FOR ILLUSTRATION AND DESCRIPTION OF A SPECIFIC SET-UP)

Most forming tools are used in lathes and are created in the tool room by tool design engineers for a special application. If they are of slab type, they will be created by surface grinding activity and ground to measurement or to a predetermined template outline on an optical viewing screen. See Chapter 14, page 92, for application of this task to a tool grinder.

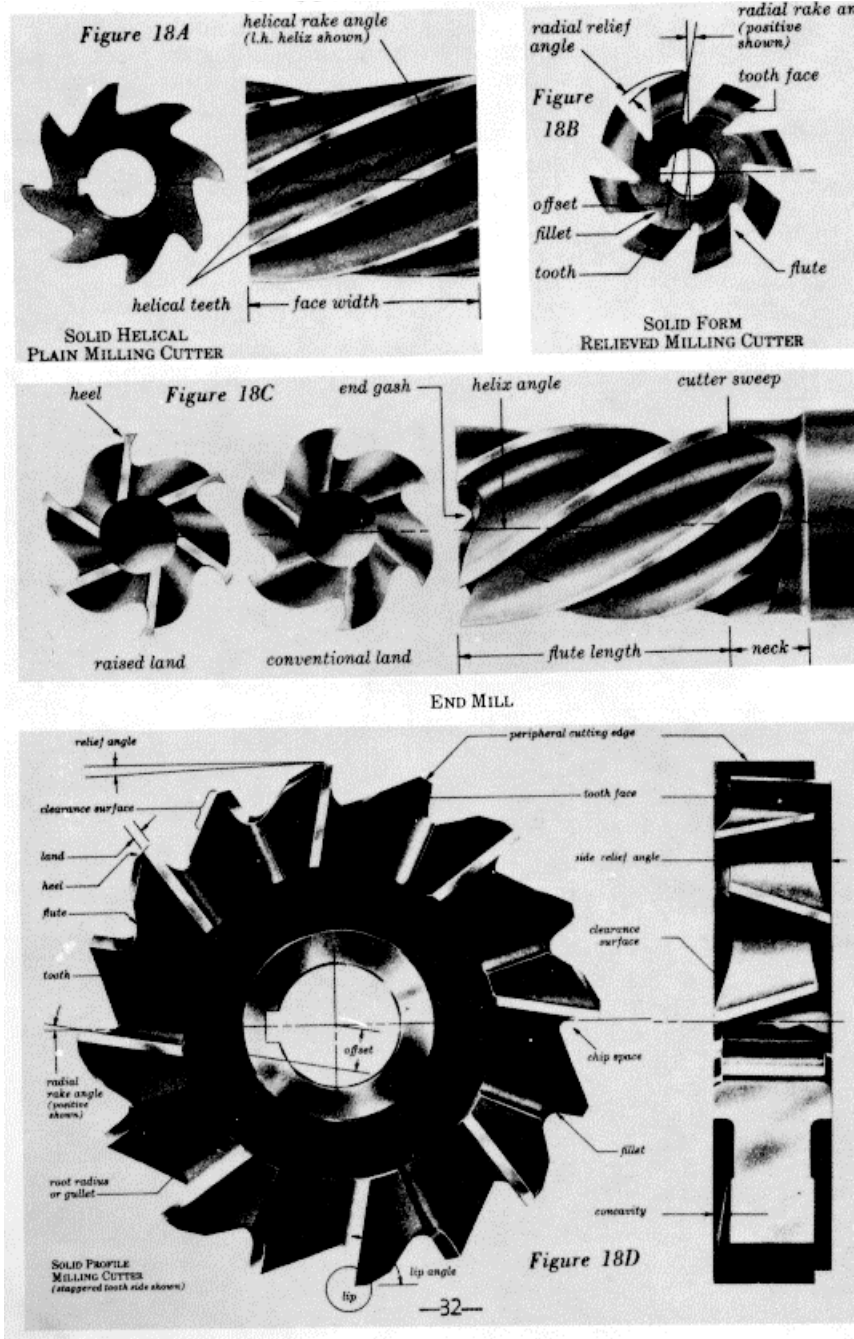
If the forming tool is circular, it must be placed on an arbor between centers and cutting face ground with any existing radial relief, as in the case of formed cutters. These cutters are created by cylindrical grinding - usually with a pre-formed straight wheel.

Instruction Manual
Section Five

CHAPTER 2

Cutter Nomenclature and Measurement

I. CUTTER NOMENCLATURE



Instruction Manual
Section Five

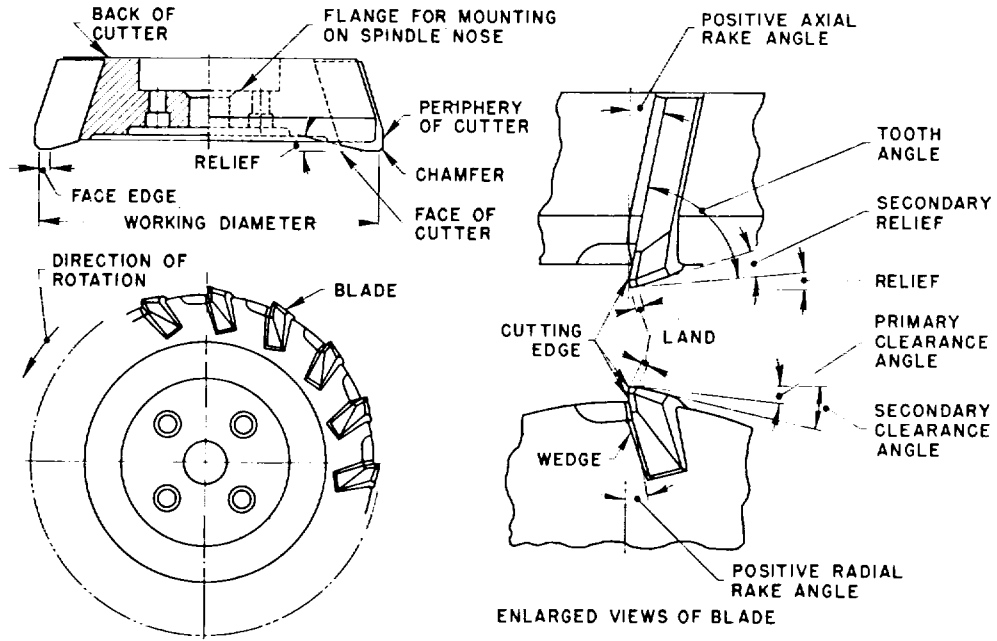


Figure 18E.-Nomenclature of a Face Milling Cutter

HAND TAPS

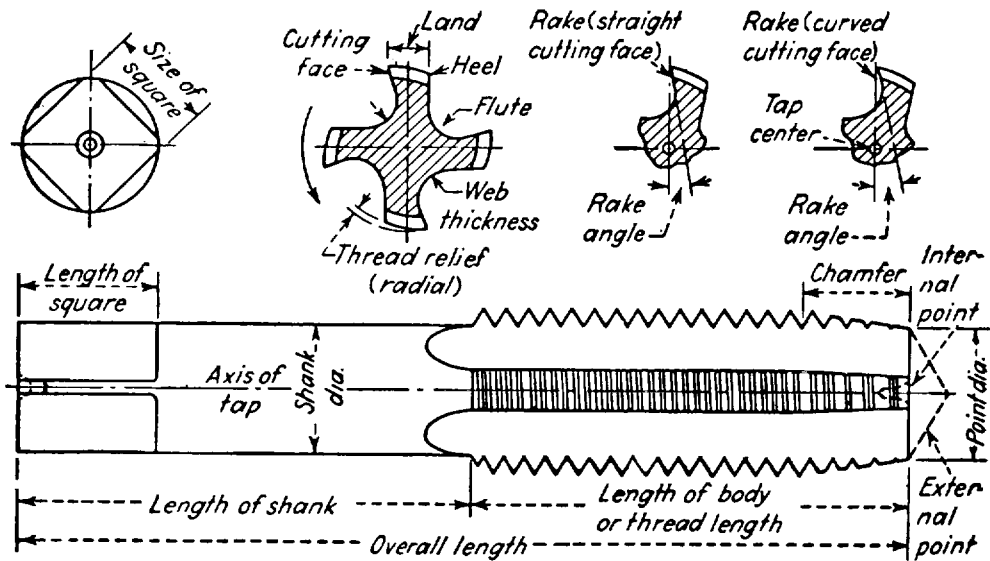
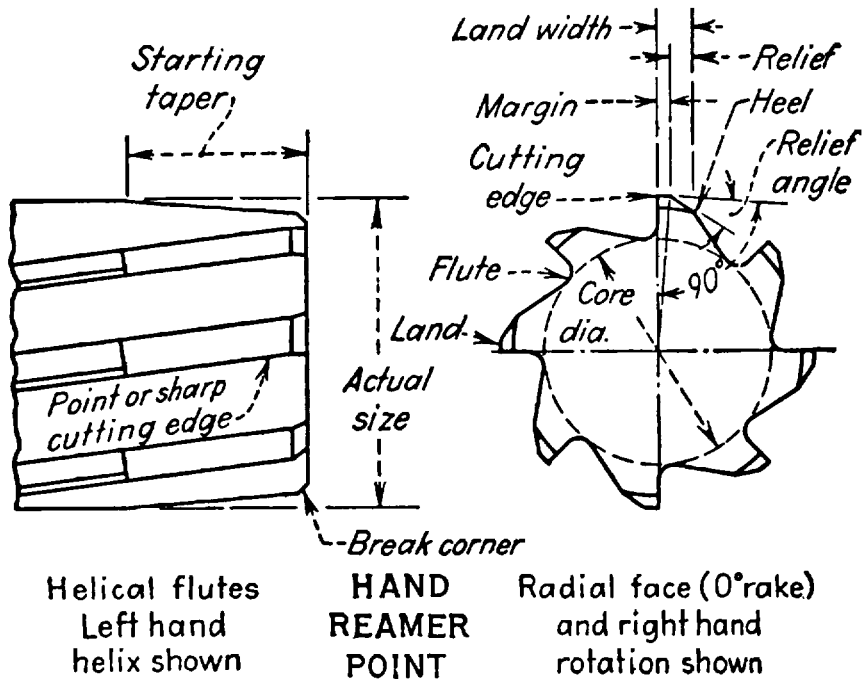
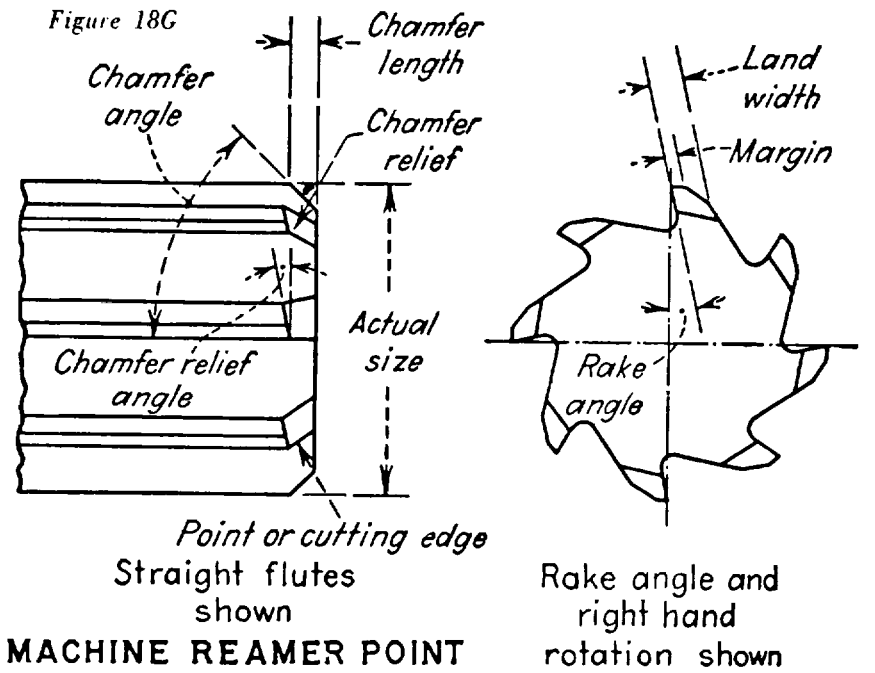


Figure 18F.-Sketch illustrating tap terms, as employed in Taps-Cut and Ground Threads, American Standard B5.4-1948.

Instruction Manual
Section Five

REAMER NOMENCLATURE



Instruction Manual
Section Five

II. CUTTER RUNOUT TOLERANCES

- A. Periodically check the runout of straight arbors used to hold cutters. Do this also for workhead spindles and their workholding adapters. Use a .0001 inch dial indicator. If It shows more than 0005 inch runout at any point on the workholding device, locate the source of the trouble before mounting the cutter.
- B. Cutters usually run as true when mounted on a tool and cutter grinder as they do in a milling machine. Only when the machinist has found the workholding fixture tending to hold inaccurately, is it necessary to use a dial indicator to check runout prior to grinding.
- C. After sharpening, it is usually assumed that the final light cut has left the cutter with no more runout than 0005 Inch. However, in the case of carbide multi-tooth cutters it is advisable to use a dial indicator to check the cutter for no more runout than given in the table below:

Cutter Diameter	Roughing Cuts		Finishing Cuts	
	Cutting Face	Periphery and Chamfer	Cutting Face	Periphery and Chamfer
Up to 12"	.001"	.002"	.0005"	.0015"
12" to 16"	.0015"	.003"	.00075"	.002"
Over 16"	.002"	.004"	.001"	.0025"

III. WHEN TO SHARPEN A CUTTER

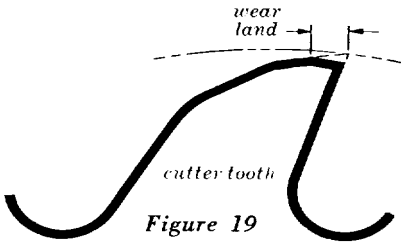


Figure 19
Figure 19.

Because of the many variables involved in milling cutter usage, it is impossible to give exact conditions of wear which will signal the time to resharpen a cutter. The Indicator used most often is a visual check of the "wear land" (Figure 19) which occurs just back of the cutting edge on a milling cutter. Depending on the type of cutter, material being machined, etc, the wear allowed may be from a few thousandths to 1/16, Inch. Other methods of determining sharpening frequency are: a predetermined time period,

depending on the number of production pieces machined; at a point where product quality begins to be unacceptable from the standpoint of finish, dimension, etc; when an increase in power is required, noise generated, or heat occurs.

IV. CUTTER INSPECTION AFTER SHARPENING

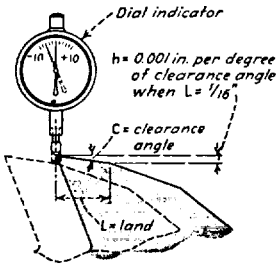


Figure 19A.

The main item to inspect on a cutter just sharpened is the clearance angle just back of cutting edges. Experienced machinists will seldom have to check these angles, but there may be conditions under which the clearance tolerances demand actual measurement. This is done with a hand operated clearance angle gauge or by means of a dial indicator. The following is a standard formula for the use of a dial Indicator to check the amount of drop from cutting edge back of the end of a given primary clearance or relief land (Figure 19A).

For each 1/16 inch width of land, each degree of clearance is approximately equivalent to .001 inch on a dial indicator. For any width of land, the clearance C in degrees = $57.32h/L$, where h = indicator reading and L = width of land in inches.

Instruction Manual
Section Five

CHAPTER 3

Plain Milling Cutters

I. SET-UP PREPARATION

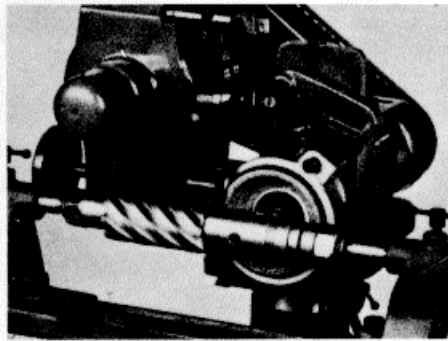


PHOTO 20

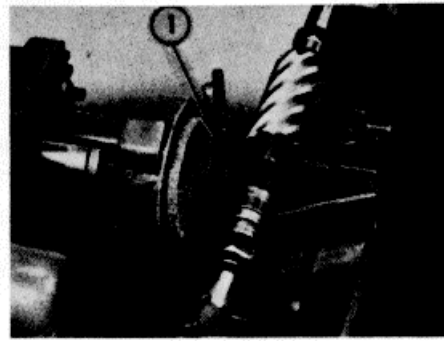


PHOTO 21

- A. Mount a cup wheel on the wheel arbor attached to spindle, or directly to the motor shaft arbor. If the wheel is already mounted on a collet, mount this assembly directly to quill nose at the opposite end from drive pulley. Install in a provisional position the wheel guard bracket and guard.
- B. Mount the cutter on a straight arbor and place the arbor between two tailstocks mounted to the machine in the approximate position shown in Photo 20. Adjust the right-hand tailstock for the necessary spring tension and then remove the arbor.
- C. Start the wheelhead motor and dress the inside of wheel to a 20 to 30 degree angle relative to the wheel face. Leave the cutting edge of wheel approximately 1/16 inch in width. Stop the spindle.

II. SET-UP FOR CLEARANCE ANGLE

- A. Swing the wheelhead (spindle) around counterclockwise to a position of 89 degrees so that cutter may be traversed across the face of the wheel (left to right) without touching its opposite side. Tighten the wheelhead to column.
- B. **For non-tilthead grinders**, place the toothrest on the wheelhead in a vertical position over the left side of the wheel face with blade end on the approximate center of wheel (SEE PHOTO 20). Mount the arbor with cutter between the tailstocks. Some red marking may be applied to the top of the toothrest blade, and a cutter tooth traversed over this to determine the point of contact. Adjust the toothrest blade so that the spot where red is removed is centered on the wheel edge, and so that the blade is no further than about .004 inch from the wheel. Using a height gauge, find the center height of the cutter or tailstock and place the blade end of the toothrest on exactly the same horizontal plane. Photo 21 shows the use of the gauge with the diamond shaped swivel plate (1) contacting the cutter tooth from above, and the toothrest from below. These contacts are reversed if the toothrest is placed over the wheel as in Photo 20. Consult Table No 11, page 105, for the correct amount to raise (OR LOWER, IF TOOTHREST IS SET FROM BELOW. AND CUTTER ENDS REVERSED) the wheelhead in order to generate the desired clearance for the primary relief. (Page 20 shows below center toothrest location.)

Instruction Manual
Section Five

- C. **For tilthead grinders**, adjust the quill swivel bracket to the desired primary clearance angle. Mount the toothrest assembly from below the wheel on the quill housing bracket as shown in Photo 22 so that the end of the blade is approximately at the center of the cup wheel on the left side; set it at the same angle as the wheel face. Some red marking may be applied to the end of the toothrest blade, and a cutter tooth may be traversed over this to determine the point of contact. Adjust the toothrest blade so that the spot where red is removed is centered on the wheel edge, and so that the blade is no further than about 004 inch from the wheel. As explained in II-B above, place the center height gauge on the table, and raise or lower the wheelhead until the blade end of the toothrest is on the same horizontal plane as the center of the cutter or tallstocks (Photo 21).

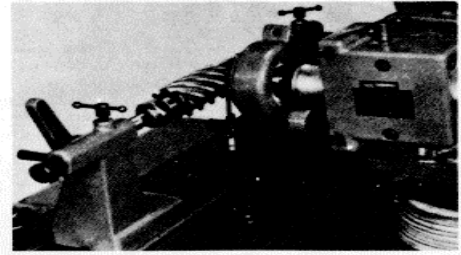


PHOTO 22

III. SHARPENING PROCESS

- A. Position a tooth of the cutter against the toothrest blade and traverse the table the full length of the cutter. In most cases, the cutter will be held by means of the workholding arbor with the left hand, and the table traversed with the right. Set a table stop for the exact length of table movement that it takes to pass the cutter tooth just beyond the wheel cutting edge, but not so far as to allow the cutter to fall off the toothrest blade.
- B. Start the wheelhead motor and proceed as above, lightly touching one tooth for its full length. Then rotate the cutter 180 degrees and grind on the opposite tooth. Check these two teeth for taper with micrometers or indicators. If taper is present, adjust the swivel table adjustment screws at the right side of table. Continue this general procedure until no taper results.
- C. Continue to grind all teeth in succession until they appear sharp. To assure roundness, start grinding a different tooth after each full revolution of the cutter.
- D. Secondary Clearance:
1. **For tilthead grinders**, adjust the quill swivel bracket to the desired secondary clearance angle. Raise the column of the machine (the entire wheelhead) until the point of contact on the toothrest is again on center with the cutter. Grind the secondary clearance angle on all the cutter teeth in the same manner as for the primary clearance, but only to a degree which leaves the primary land between 1/32 and 1/16 of an inch in width.
 2. **For non-tilthead grinders**, leave the toothrest in the same position as for grinding the primary clearance, but raise (or lower) the wheelhead the required amount for the secondary clearance to equal that existing on the cutter. Consult table II, page 105 if a specific secondary clearance is indicated. Grind all secondary clearance angles as above, leaving the required primary land width. (Page 20 shows below center toothrest location.)
- E. Stop wheelhead motor and remove cutter for final inspection. Most small and medium cutters should not have more than .0005 inch run-out on the periphery.

**Instruction Manual
Section Five**

CHAPTER 4

Shell End Mill and Other End Mills

I. SET-UP PREPARATIONS

The set-up for the periphery is the same as for a Plain Milling Cutter except that the cutter is held in a workhead with an adaptor arbor or collet rather than being held between centers. See Chapter 3, page 36. The air-bearing workhead for grinding end mills is described in Chapter 14, page 92.

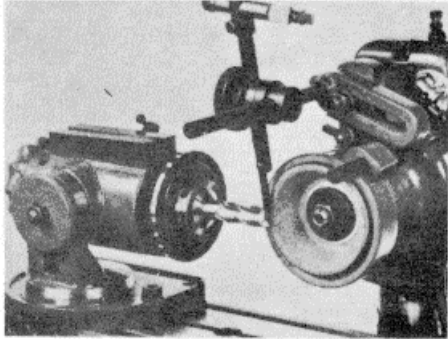


PHOTO 23

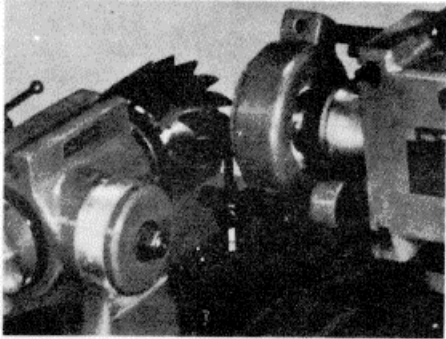


PHOTO 24

II. SETTING THE CLEARANCE ANGLE

- A. **For non-tilthead grinders**, the cutter is most easily sharpened with the cutting edge facing up at the point of contact with the wheel (Photo 23), and the workhead such as B942, placed at the left end of the table. This method is recommended for right-hand end mills. If the cutter is a left-hand end mill, then the workhead should be placed toward the right side of the table, working from the right side of the wheel, with the toothrest in both cases being attached to the bracket over the wheel. (Page 20 shows below center toothrest location.)
- B. **For tilthead grinders**, the toothrest will generally be held from below the cup wheel, and the workhead will be placed at the right or left side of the table, depending on the rotation of the cutter (right or left hand).

III. SHARPENING PROCESS PERIPHERY

- A. Repeat the same peripheral grinding sequence as described in Chapter 3, the cutter being cammed on the rigid toothrest.
- B. When using a workhead such as the B942, set a stop on the table to limit the travel of the workhead toward the wheel. This stop will prevent the cutter tooth from sliding off the toothrest. When the machine is operated from the front, the right hand usually moves the table travel while the left hand holds the workhead hand-nut, indexing or camming the tooth flute against the toothrest. If the end mill is left hand, or if the toothrest is from below the wheel, the reverse usage of hands will be necessary. See Photo 24.

IV. GRINDING THE FACE AND CHAMFER

- A. **Using a Non-Tilthead Grinder:**
 1. Assuming the cutter has a chamfer (corner angle), locate the center of the chamfer of a tooth face with a pencil, and put this point on the same horizontal plane as that of the center of the cutter by means of the height

Instruction Manual
Section Five

gauge. Lock the workhead spindle with the spindle in the horizontal zero degree position.

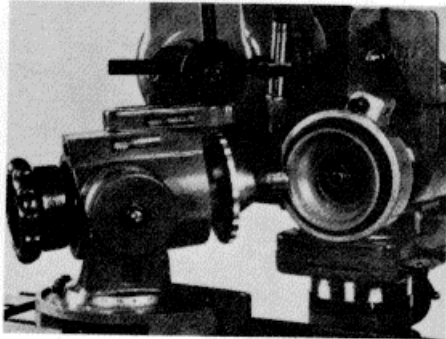


PHOTO 25

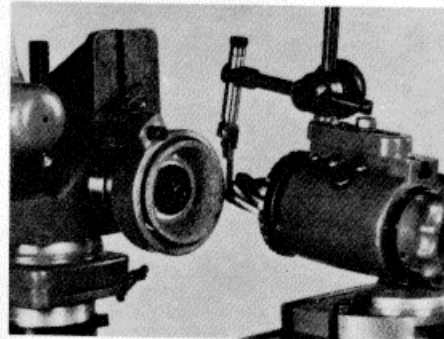


PHOTO 26

2. Mount the toothrest assembly on top of the workhead in a position as shown in Photo 25, if the cutter edge to be sharpened is facing up. Or, the toothrest may be set on the table, pointed upwards at the tooth edge, if the latter is to be faced downward at the point of grinding. Use the micrometer toothrest with spring-loaded rest, positioning the blade as close to the end and edge of the tooth flute as possible. The blade must be able to spring outward when the cutter is rotated for sharpening the next tooth.
3. Rotate the workhead laterally to the desired chamfer angle and lock, positioned on the table relative to the wheel as shown in Photo 25.
4. Loosen the vertical swivel of the workhead and tilt it up (or down), as shown, to produce the desired primary clearance, then tighten.
5. Grind the primary clearance on all teeth. Without moving the toothrest, repeat the above process for the secondary clearance by further tilt of the workhead. Grind the secondary clearance to where the primary land is 1/32 inch to 1/16 of an inch in width.
6. To sharpen the face (ENDS) of the teeth, first use the height gauge to put a tooth in the same horizontal plane as the center of the mill. Lock the workhead spindle. Create a toothrest set-up similar to A-2 above, only working from the right side of the wheel if cutter edge is to face up at the point of contact. If the cutter edge is to face down at the point of contact, the toothrest will be set on the table, pointed upward at the left front edge of the tooth flute. In the latter case, complete step 8 below first.
7. Swivel the workhead in the horizontal plane so that the face of a tooth will parallel the table travel, thus maintainning the radial cutting land relief toward the center of the cutter. This is usually on the order of several degrees slope toward the center of the mill. Lock the lower swivel.
8. Loosen the vertical swivel of the workhead, tilt it to the desired primary clearance angle, and lock. Photo 26 shows this operation, with the workhead at a compound angle with the swivel table to achieve the necessary distance from the workhead to the wheel.
9. Begin grinding the primary clearance, checking tooth initially for proper

Instruction Manual

Section Five

bearing from front to rear. If teeth lands show a taper, make small adjustments on the table swivel

10. After the teeth appear sharp, loosen the workhead vertical swivel and adjust the workhead tilt to the desired secondary clearance angle, then lock. Grind the secondary clearance as in t9) above until each tooth has a primary land of no more than 1/16 inch in width.
11. If it is desirable to grind a heel on the face of the mill, reset the workhead to the primary clearance angle tilt, swivel the workhead in the horizontal plane to a setting of 87 degrees, lock, and grind the face on all teeth until the length of the primary is no longer than about 1/8 inch.
12. If the end mill is too long so that when installed in the conventional workhead it does not permit room between its end and the wheel, the swivel table on the grinder may be moved off its bed rests at its ends and swiveled to some convenient angle which allows the workhead to clear the wheel sufficiently. Simply set this angle used on the swivel table as a correction factor on the horizontal swivel of the workhead.

B. Using a Tilthead Grinder:

Repeat all steps in IV-A above as necessary, only wherever the instructions call for tilting the workhead, instead tilt the wheelhead for the desired primary or secondary clearance, leaving the workhead set at 0 degrees in the vertical plane. Note the tilting wheelhead in Photo 24.

CHAPTER 5

Straight Tooth Side Milling Cutter

I. SET-UP PREPARATION FOR PERIPHERY

Refer to Chapter 3-1, page 36 for initial instructions on position of the cutter, how it is held, the wheel used, etc. If the cutter teeth have no helix, the toothrest should be mounted on the table for fastest indexing of teeth across the wheel. Each tooth is held firmly against the toothrest blade and each ground in succession, using the same principles described in Chapter 3 and Chapter 4.

II. SET-UP FOR CLEARANCE ANGLE AND THE SHARPENING PROCESS

Refer to Chapter 3 for information on clearance angles when the toothrest is mounted on the wheelhead. When the toothrest is mounted on the table, place a tooth on the toothrest blade and then place the end of the blade at the same center height with the center of the cutter by using height gauge. Rotate cutter tooth downwards by means of the micrometer adjustment to create necessary clearance. Engage cutter with wheel and sharpen as described in Chapter 3. See Photo 27.

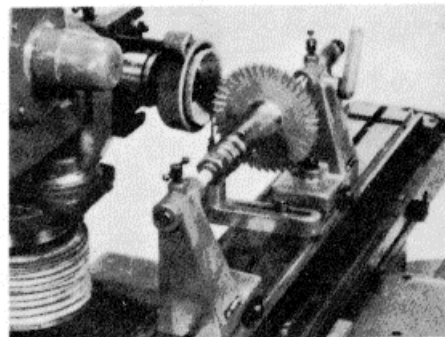


PHOTO 27

III. SET - UP FOR SHARPENING THE SIDE TEETH

The set-up is similar to that of grinding the face (teeth ends) of a shell end mill (SEE CHAPTER 3). Place the cutter in a universal workhead. Sides of the teeth should be ground with at least .001 inch back taper on the primary clearance so that the teeth are larger at the periphery of the cutter. Repeat this process for both sides of the cutter.

Instruction Manual
Section Five

CHAPTER 6

Stagger Tooth Cutter

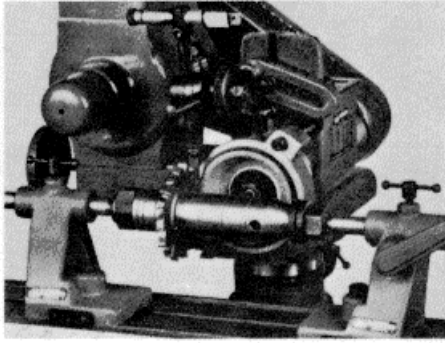


PHOTO 28

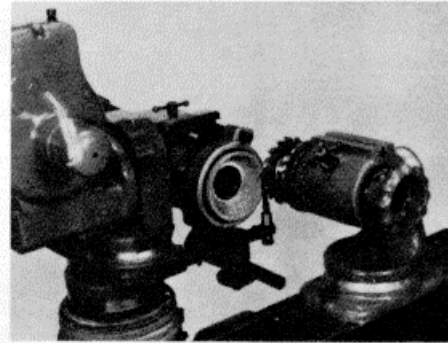


PHOTO 29

I. SET-UP PREPARATION FOR PERIPHERY

Refer to Chapter 3-1, page 36, for the initial procedure in holding the cutter, for the wheel used, etc. Refer to Photo 28 for approximate location of the cutter on the machine and the cutter relative to the wheel. The toothrest should be placed on the wheelhead at the approximate wheel center and the high point of its blade brought on center with the center of the cutter. If an inverted "V" blade is used, the angle from horizontal should be at least a 5 degree slope on either side greater than the cutter helix. (Page 20 shows below center toothrest location.)

II. CLEARANCE ANGLE PROCEDURE AND SHARPENING PROCESS

- A. Refer to Chapter 3, for information on clearance angle generation. Leave a very slight gap between the cutter periphery and the wheel when setting the clearance. Move the table enough to take the cutter off the rest. Regardless of whether the toothrest is placed from above the wheel or from below, follow the procedure listed in B through E below.
- B. Start wheelhead motor. Move the table and cutter until one tooth lightly contacts the taper or curved portion of the toothrest blade somewhat before its high point while firmly holding the cutter against the blade. When the cutter edge is opposite the wheel edge, advance the crossfeed enough to make slight contact with the wheel and continue the pass with the tooth until off the high point of the blade, off the wheel edge, toward the insider of the cup wheel. At this point, return on the same tooth until off the wheel edge (outside the cup wheel) to insure that the full length of the tooth was ground.
- C. Rotate the cutter 180 degrees, select a tooth with appropriate helix direction, and repeat the same process, but traverse all the way off the toothrest blade on the inside of the wheel. Rotate the cutter to the next tooth (with the opposite helix direction) and traverse back in the opposite direction.
- D. Stop the wheel and check the two cutter teeth just ground for comparative tooth height with a dial indicator if there is over .0005 of an inch difference,

Instruction Manual
Section Five

slightly loosen the Hand-Nut on the BA940 toothrest that holds the toothrest cross arm and blade rigid, and move the cross arm and blade slightly toward the high tooth, reclamping the Hand-Nut. Grind the next two teeth and check them again. When height is within tolerance, continue to sharpen the primary relief on all teeth until they appear sharp.

- E. Grind the secondary clearance, as explained in Chapter 3, but with the following modification. Since the stagger tooth cutter has differing axial rake angles for each helix direction, it is necessary to grind one set of teeth completely, then the other. Select a tooth and mark its center with a pencil, using the height gauge. Place the mark on the centerline level of the cutter. Rotate the cutter above or below this mark for desired secondary clearance by wheelhead movement, or move the toothrest by using a micrometer toothrest, its blade positioned against the same tooth. Swivel the table 2 to 6 degrees depending on the axial rake. The wheelhead should be in horizontal position (zero degree tilt).
- F. If it is necessary to grind the side teeth (to reduce cutter width, for example), place the cutter on an adapting arbor and mount it in a universal workhead. The set-up and procedure are similar to grinding the side teeth of a straight-tooth milling cutter, or the face of a shell end mill (see pages 38 or 44). Refer to Photo 29. Teeth are leveled with a gauge; then the workhead spindle is locked. Mount the toothrest assembly on either the workhead or the table, using the spring-loaded micrometer blade. Grind one set of teeth at one setting (primary and secondary); then reverse the cutter on the arbor and grind the other set. By means of the swivel table, place about 1/2 degree back taper on the primary clearance to create a larger cutter width at the periphery of cutter.

CHAPTER 7

Angular Cutters

I. PREPARATION FOR SHARPENING THE PERIPHERY

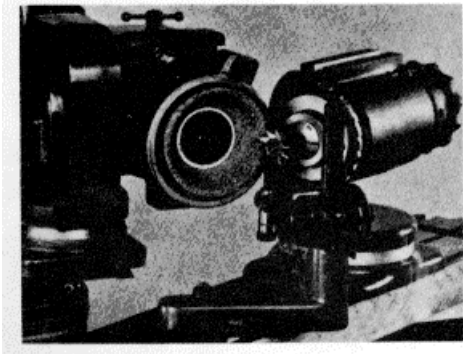


PHOTO 30

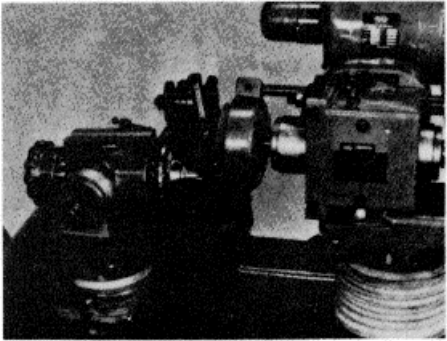


PHOTO 31

- A. The set-up for sharpening an arbor-mounted angular cutter is the same as that for sharpening the periphery of a plain milling cutter, except that the table

Instruction Manual

Section Five

must be swiveled the angle equivalent to that between the cutting edges and the axis of the cutter. See Chapter 3, 1 and II. If the angular cutter is to be shank mounted in a workhead, the set-up is identical to that of a shell end mill, except that the table or workhead must be swiveled in the horizontal plane to the angle of the cutter. See Chapter 4, 1 and II. The toothrest is mounted on either the wheelhead or the table.

- B. With some shank-mounted cutters, interference between the shank and the flared cup wheel used in the above set-ups will prevent sharpening the full length of the teeth. When this interference occurs, substitute the following set-up, which also produces a constant clearance angle.

II. SET-UP FOR SHARPENING THE PERIPHERY WITH A SAUCER WHEEL

- A. Mount a saucer wheel on a spindle collet or arbor opposite the belt-driven end of the spindle, and mount the appropriate wheel guard. Start the wheelhead motor and dress off the periphery of the wheel to a width of 1/8 inch with a diamond dresser. Stop the wheel.
- B. After placing the axis of the spindle parallel with the table travel, tighten the wheelhead swivels. Mount the universal toothrest assembly on the table or workhead from above or below the cutter, depending on whether the cutter edge faces up or down at the point of contact with the wheel. With the use of the height gauge, place the blade end of the toothrest on centerline with the cutter center just back of the cutter O D, on one tooth. Also place the centerline of the cutter on the same horizontal plane as the centerline of the wheel. Set the index dial of the wheelhead handwheel to 0.
- C. Lower or raise the wheelhead the required amount according to Table 1, page 104, in order to generate the desired clearance angle.
- D. With the cutter teeth set parallel to the table travel (as in I-A above) and the cutter held against the toothrest, traverse a tooth by the periphery of the wheel to the left or right of the wheel to a point where the wheel edge just avoids the shank of the cutter. At this point, set a table stop to limit further travel in this direction.
- E. Start the wheelhead motor and proceed to grind the primary and secondary clearance on all teeth as in the chapters mentioned above.
- F. Sharpening the face and chamfer is done as described for end mills in Chapter 4, IV, using a cup wheel (see Photo 31).

CHAPTER 8

Face Mills

Face mills up to 14 inches in diameter may be sharpened on machine model series BA900 or B2000 by use of a raising block under the workhead, while standard workhead height allows for sharpening cutters up to 12 inches in diameter. The B6000 series machine models allow face mills up to 16 inches in diameter to be ground without the addition of raising blocks. Face mills of no larger diameter than 10 inches may be mounted and sharpened on the B300 series machines.

The following is the operations procedure for sharpening a 12-inch diameter face mill with inserted carbide blades with cutter edges having an end relief of 2 de-

Instruction Manual

Section Five

grees toward the cutter center, with a chamfer of 60 degrees from parallel with the axis of cutter; with simulated peripheral cutting edges; all cutting edges having only one relief angle of 5 degrees (for chamfer and face). Instructions are for non-tilthead grinders unless otherwise noted.

I. SHARPENING THE CUTTER FACE

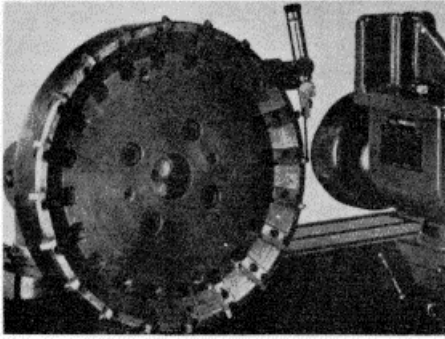


PHOTO 32

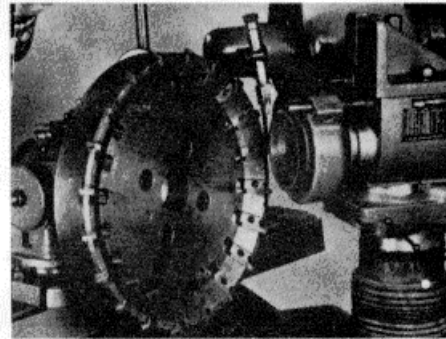


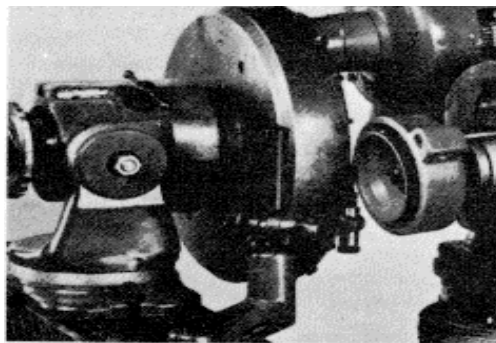
PHOTO 33

A Set-up Preparation

1. Place a diamond flared cup wheel or other suitable wheel on the wheel collet or mounting arbor and attach it to the spindle. Select the proper wheel speed by use of the correct pulleys and belt. Place the axis of the wheel at a 90-degree angle (OR AT AN 89-DEGREE ANGLE IF CLEARANCE IS NEEDED ON OPPOSITE SIDE OF WHEEL) to the table travel of the machine and with the use of the height gauge, place the wheel center at the same height as the workhead center (centers of tailstocks may be used as a gauge for the height of the workhead).
2. Place large, sensitive workhead at the far right of the swivel table with its base about 3 inches in from the end. Align the workhead base with the table T-slot by tightening the base plate clamp bar assembly to the outer edge of the table with the hex socket screw. Tighten the two base plate T-slot bolts. Turn the correct workhead spindle taper toward the rear of the machine (see Photo 32) by loosening the swivel stud nut on its base and rotating the workhead until the index mark lies at 90 degrees. Tighten the swivel stud nut. Loosen the upper swivel nut on the workhead, tilt the workhead up or down to obtain the desired primary clearance angle back of the cutter faces (5 degrees in this instance), and tighten the upper swivel. **NOTE:** The B992 workhead must be tilted upward on all machines; the B9092 may be tilted either up or down. (See photo 33).
3. Place the cutter with its milling machine arbor in the workhead and tighten the draw-bolt assembly. Care must be taken to keep taper surfaces clean and un-nicked. Loosen the clamp bar holding the swivel table at the right side of the machine and use the table adjusting screw to advance the table inward at the right so that the pointer at the left side of the table shows 2 degrees. It may be necessary to loosen slightly the center swivel friction locking screw of this table. Tighten the clamp bar.

B. Toothrest and Clearance Angle Settings:

1. **Non-tilthead grinders:** Prior to setting the toothrest, adjust the workhead upward to the necessary primary clearance angle. The base of the universal toothrest may be clamped on top of the workhead or on the top of the swivel table, depending on the size of the cutter and the position of its blades. The position recommended for ease of set-up, as shown in Photo 32, is with the toothrest blade pointed down onto a cutter blade face which is facing up at the point of contact for grinding the relief. Using the height gauge, adjust the toothrest blade onto the face of one blade so that the blade is at the approximate center of the wheel and the periphery of the cutter face is at the same height as the center of the cutter. Use the micrometer with spring-loaded blade as shown in the photo and adjust it to hold the cutter from rotating up at the point of grinding, and so that it will not be touched by the wheel. The toothrest blade must be free to spring aside when the mill is rotated. In order to bring the next blade into grinding position. Under same conditions, it may be possible to set the toothrest from below the wheel, as shown in Photo 33 (photo shows periphery being sharpened). (Page 20 shows below center toothrest location.)

**PHOTO 34**

2. **Tilthead Grinders:** Mount the universal toothrest base on the table as shown in Photo 34, and then position the toothrest blade to the approximate center of the wheel at the wheel edge (EITHER SIDE DEPENDING ON CUTTER ROTATION AND SET-UP) so that it will not touch the wheel. Care must be taken to see that the toothrest will allow other blades of the cutter to clear the wheel during the sharpening process. Center the cutter blade edge to be ground with the cutter center, as described in B-1 above. Loosen the swivel wheelhead bracket screws, tilt the wheelhead to the desired primary clearance angle, and tighten.

3. If the cutter has teeth with significant radial rake, mount the toothrest on the wheelhead. Modify steps 1 and 2 above accordingly.

C. Grinding Procedure:

1. Engage the table transmission to the greatest reduction and traverse the table to the left (or right) to a point where a blade cutter face will pass beyond the wheel edge toward the center of the wheel. Set a stop at the right (or left) end of the table to limit further travel in this direction.

- 2 Install the wheel guard in a position that will not contact the mill when traversed for grinding and that allows visual observation.
- 3 When the toothrest is fixed on the column as in part B-3 above, traverse the table in the same manner as in C-1. The cutter blade is passed over it to the left (or right) up to a fixed stop which keeps the cutter on the toothrest, but past the wheel edge.
- 4 Advance the crossfeed of the machine to a point where one of the blades about .06 inch from the wheel edge and start the grinding wheel, being certain that the wheel periphery is rotating in a direction that will drive the cutter blade against the toothrest.
- 5 Standing at the front of the machine (OR SIDE, IF THE MACHINE HAS BACK OPERATED CONTROLS) and holding the cutter face against the toothrest, continue to move the crossfeed in slowly until the wheel has just contacted the blade at some point on its clearance. Begin to traverse the table slowly to the left (or right) until the stop is reached, then return until the blade has passed to the right of the wheel edge. Rotate the mill so as to bring a new blade into contact with the toothrest (IN PHOTO 32, THIS IS COUNTERCLOCKWISE FACING THE REAR OF THE CUTTER FROM THE MACHINE FRONT). Use a red marking pencil and mark the tooth just ground. Continue the above operation for each inserted blade. When the red-marked tooth appears again on the toothrest, examine all blades to see if the wheel has contacted all of them equally. Advance the crossfeed no more than .001 inch and proceed to sharpen all the blades again, repeating process until the cutting edges appear to be sharp. No light will reflect from a sharp edge.

II. SHARPENING THE CHAMFER

(SEE PHOTO 36)

- A Set-up preparation assumes steps I, 1 and 2 are completed. Without moving the face mill in the workhead or the workhead relative to the table and without changing the clearance angle setting for the blade cutter faces, swivel the upper table to the desired chamfer angle (60 DEGREES IN THIS INSTANCE) relative to the subtable. Tighten the center friction lock screw on the swivel table.

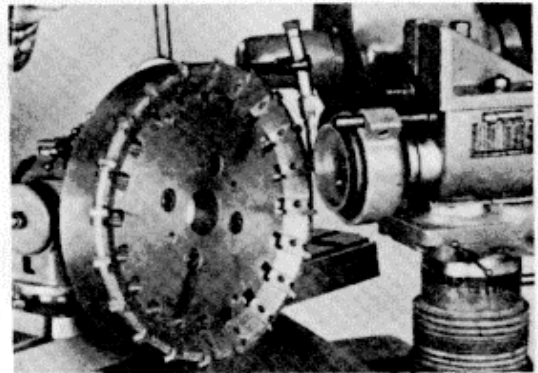


PHOTO 36
PHOTO 36

- B Toothrest and Clearance Angle Setting:

1. **Non-tilthead grinders:** Re-adjust the toothrest so that the micrometer can be used to obtain final clearance adjustments if desired. In most cases, chamfer clearances can be produced by merely matching visually the existing clearances with the vertical surface of the wheel edge. The clearance angle setting for the cutter faces will approximate this chamfer clearance angle when new blades are being ground, by simply grinding at the desired chamfer angle until the chamfer clearance surface meets the cutter face and periphery clearance surfaces. If exact corner clearances are necessary, see Table V, page 107.

2. **Tilthead grinders:** Instead of tilting the workhead, place the workhead axis level with the table, and adjust it for the necessary chamfer angle. Take chamfer clearance directly from the tilt of the wheelhead by the visual method, or from the corner clearance table on page 108.

C. Grinding Procedure:

1. The wheelhead may have to be raised slightly to allow the rear portion of the upper swivel table to clear under the bottom of the dovetail slide of the wheelhead. Adjust the wheel guard as necessary.
2. Proceed to sharpen the chamfer by the steps indicated in Part I-C. The left side of the cup wheel will be used in the set-up shown, necessitating a stop set on the table at the left side to limit maximum travel to the right in the set-up shown in Photo 36, the wheel will be operated in a clockwise direction. Under some conditions, it may be advisable to advance the crossfeed of the machine out to a point where the base of the workhead can be placed more directly over the center of the swivel table for maximum stability.

**III. SHARPENING THE PERIPHERY OF THE CUTTER
(BLADES PARALLEL OR APPROXIMATELY PARALLEL TO THE CUTTER AXIS)
(SEE PHOTO 33)**

A. Set-up Preparation:

1. Completion of the foregoing procedure for sharpening the faces and chamfer clearance surfaces is assumed to be complete.
2. Move the base of the workhead in approximately 10 inches from the right side of the swivel table. Place the axis of the workhead (and cutter) at a 90 degree angle relative to the swivel table and lock. Return the workhead to the level or 0 degree setting for the vertical swivel. Turn the swivel table to a 90 degree angle relative to the subtable and lock.

B. Toothrest and Clearance Angle Settings:

1. Place the toothrest base on the workhead or table top (depending on the cutter size) and adjust the micrometer blade end to hold the cutter blade from above the wheel, or from below if space permits and the cutter edges are to face down at the wheel contact point. **NOTE:** Some face mills have a marked helix angle of the peripheral edges relative to the cutter axis. In this situation, the toothrest must be placed on the wheelhead in a fixed position over (OR UNDER) the wheel, and the cutter peripheral faces traversed relative to this rest to obtain a uniform clearance land. The grinding process is the same then as described in the chapter on stagger tooth cutters (Page 20 shows below center toothrest location.).
2. It may be necessary to work on the lower left (OR RIGHT) portion of the grinding wheel in order to clear the wheel with the other cutter blades or the toothrest mechanism, as shown in Photo 33. It is advisable to keep heavy cutters well centered over the grinder subtable.
3. After placing the cutter blade face at the same height as the workhead center, obtain the amount to raise (OR LOWER) the toothrest micrometer from the clearance Table II, page 105, to give the desired clearance angle.
4. Note on Secondary Clearance Angles: If the cutter has this feature, follow the steps in set-up procedure

given in parts I, II, and III for primary clearance. Match the secondary clearance angles on the cutter or use the suggested clearance from table V, on page 107. The toothrest may have to be adjusted, the workhead tilted one way or the other farther (IN THE VERTICAL PLANE), or, when the machines have a tilting wheelhead, the wheelhead tilted farther than the primary angle setting. Sufficient grinding is accomplished in order to reduce the primary land to about X6 or 12 inch in width.

C. Grinding Procedure'

The process duplicates that given in parts I and II for the face and chamfer clearance lands, except as noted in B-1 above.

CHAPTER 9

Form Relieved Cutters

Form relieved cutters are sharpened by grinding the teeth faces as pictured in Photos 37, 38, 39, 40, 41, 42 Figure 37A shows the correct and incorrect way to sharpen these cutters On K. O Lee grinders, the usual method of grinding these

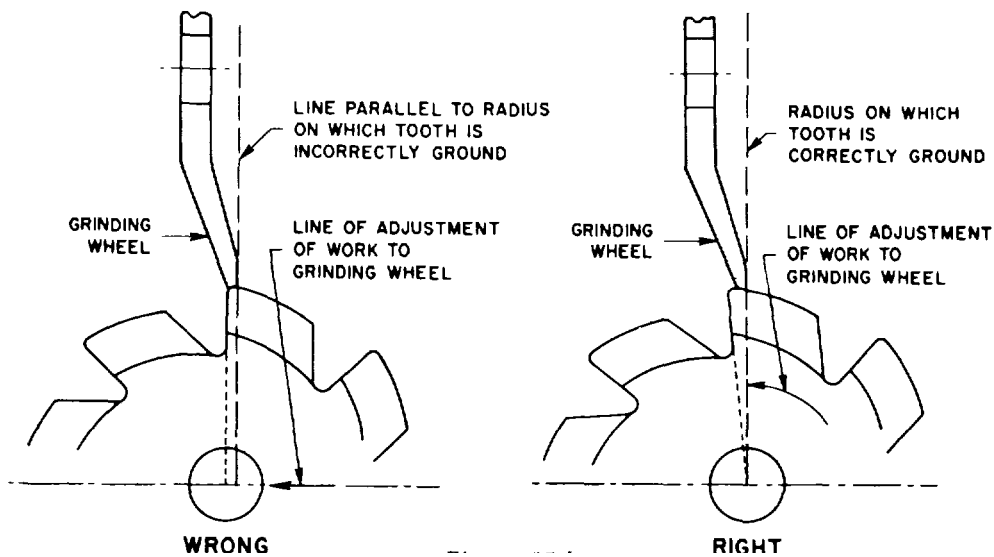


Figure 37A.

cutters is to place them between centers, sharpening them with a saucer wheel. Certain formed cutters, such as Fellows gear shaper cutters, are sharpened by rotating them in with a motorized workhead. This process is described at the end of the chapter New form relieved cutters should have the backs of the teeth ground prior to using these surfaces for indexing with a toothrest This is done for the purpose of creating indexing points on the cutter teeth which are equally distant from the center of the cutter as well as to provide teeth backs which are parallel with any axial helix that may exist on long cutters. From the foregoing, it can be seen that grinding the teeth backs is one of the important factors in

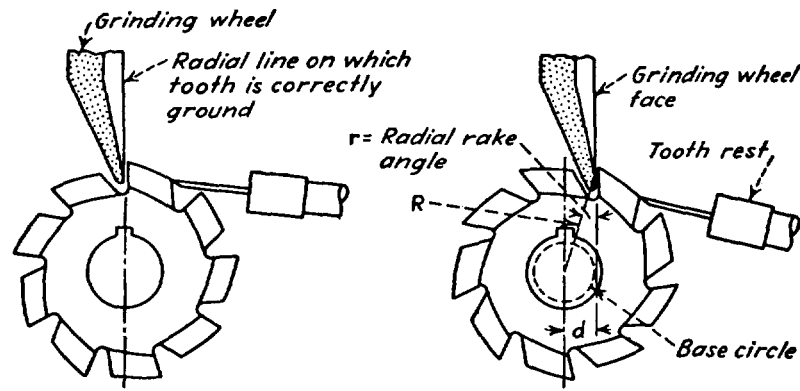


Figure 37B.--Form-relieved cutters are jace-sharpened only.

producing uniform tooth height which insures the successful operation of these cutters.

Formed cutters may have no radial rake or may have positive undercut or negative rake. They may have axial rake (HELIX) with no radial rake or have both in combination.

I. GENERALSET-UP FOR GRINDING FORMED CUTTERS WITH "ZERO RAKE"

If the cutter is new, follow Step A below, and then proceed to page 52 for final details on grinding teeth backs.

A Referring to Photo 37, mount a saucer wheel on the wheel arbor as shown and place the wheel spindle or motor shaft at a right angle to the grinder table. The wheel O D should be checked for thickness to make sure that it will fit into the flute gullets. Some dressing of the wheel edges may be necessary. Mount a wheel guard as shown, and raise the wheelhead so as to put the bottom of the wheel even with the center height of the tailstocks, which are mounted as shown in the photo. The flat face of the wheel should face the front of the grinder.

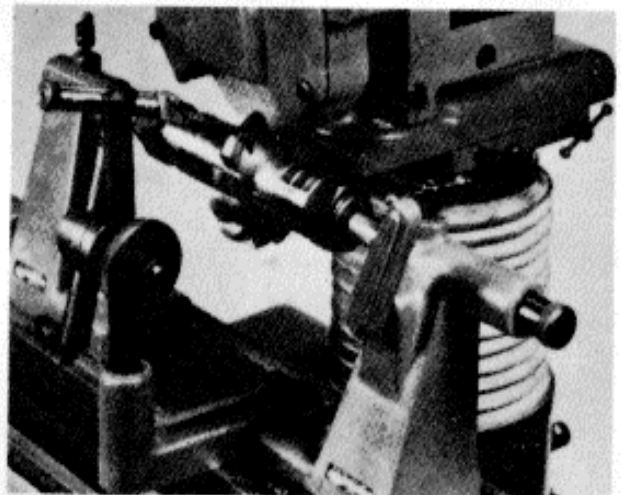


PHOTO 37

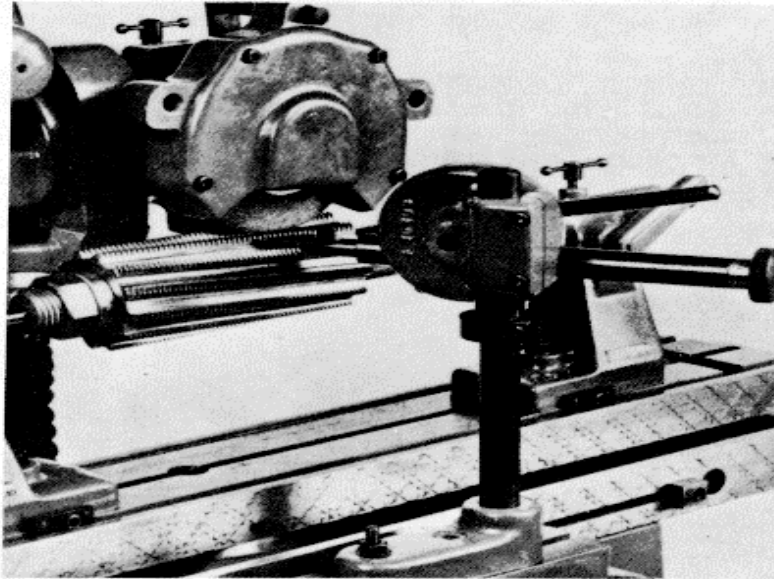
- B. Move the crossfeed so as to bring the centerline of the tailstock centers directly in the same vertical plane as the flat face of the saucer wheel. Use the point of the tailstock centers to check this alignment. After this is done, set the machine crossfeed index dial to 0, as this will be the "zero rake" position for the cutter face.
- C. Move the crossfeed out far enough to allow the cutter to be placed between centers. **(COUNT THE NUMBER OF HANDWHEEL REVOLUTIONS, IF MORE THAN ONE).** It is also possible to move the table to one side of the wheel when mounting the arbor or to raise the wheel above the tailstocks as shown and mount the cutter which has been placed on a straight arbor. The teeth faces on top are pointed toward the rear of the grinder.

- D Mount the universal toothrest on the grinder table, as shown in Photo 37 and using the micrometer with the spring loaded blade, place it near the back of the tooth to be ground and lock the hand-nut temporarily. Now reposition the machine crossfeed in to a point where the original 0 point was reached. Do not go beyond this point on the crossfeed. Adjust the wheelhead vertically so that the periphery of the wheel fits near to the bottom of the flute gullet. If for some reason the 0 crossfeed position does not allow the face of the tooth to align flush with the wheel face, there are two possible courses of action:
- 1 The cutter may have been improperly ground before. This will mean that the crossfeed of the machine will have to be adjusted to allow for whatever rake does exist.
 - 2 If the absolute zero rake is to be maintained, then the wheel will have to be raised to a point where surface grinding activity can be undertaken to grind away the rake that does exist.
- E. With a tooth face held against the face of the wheel, adjust the toothrest blade against the back of the tooth high enough so that it can spring upward and clear the next tooth when the cutter is indexed. Also, check to see that there is some adjustment left in the micrometer screw so the cutter may be advanced into the wheel as the sharpening proceeds. Tighten the swivel joints and screws of the toothrest mechanism firmly.
- F. Move the crossfeed out (AWAY FROM THE WHEEL FACE) slightly and traverse the table to determine the length of stroke for passing the cutter under the wheel. The lowest point on the wheel should be passed completely by the flute gullet. Set a table stop to limit the table travel in one direction. Start the wheel motor with the cutter to one side and begin a trial run around the cutter teeth, passing each in succession under the wheel. Continue this process while advancing the crossfeed to the 0 point on its dial. From this point on, all advancement of the cutter faces into the wheel will be accomplished by adjusting the toothrest micrometer small amounts. This process rotates the cutter about its axis, thus preserving the radial rake (IF ANY) on the cutter. During the sharpening process, be sure to hold the cutter firmly back against the toothrest blade.
- G. The actual grinding process is change slightly if large amount (on the order of 0.20 inch) of stock must be removed in order to create a sharp cutting edge. In this situation, the grinding wheel should be raised just above the tooth face after step E. Eliminate step F and traverse the table back and forth holding the cutter firmly against the toothrest blade and at the same time periodically lowering the wheelhead. This results in a surface grinding action which will cut into the tooth from the top and quickly wear away the excess tooth stock.
- H. On the last pass, take a light cut and cover all teeth with this final setting of the micrometer. After grinding is completed, the concentricity of the cutter should be within .0005 inch when checked on the arbor between centers.

II. GRINDING A FORMED CUTTER WITH AXIAL RAKE OR HELIX

Repeat all steps above except A and B which are modified as follows. Instead of leaving the grinding wheel spindle or motor shaft at a right angle with the table, rotate either one of the swivels of the wheelhead the number of degrees required by the axial rake. This must be done only after placing the wheel face in the vertical plane with the centerline of the tailstocks. If this angle is not known or started on the cutter, place the cutter between the tailstocks and

align the face of the wheel with the axial rake of the tooth face during step C.



NOTE: CUTTERS WITH A LONG AXIAL RAKE (HELIX): Most hobs have some axial helix. Photo shows the set-up when it is necessary to slide the formed cutters along a fixed toothrest. The B1070 spiral grinding fixture is the ideal way to grind these cutters on a K.O. Lee grinder as shown in photo. Cutters are traversed in the same manner as other spiral milling cutters. Work from left to right (and then back) for the initial traverse by the wheel. Set the wide rest blade to precede the wheel cutting edge somewhat as this will allow the cutter tooth face to cam on the blade prior to striking the wheel. Use the micrometer of B1070 to advance the hob teeth into the wheel. In order for the wheel to contact the spiral tooth on a tangent line only, it is necessary to use the angular side of the saucer wheel. Place the angular face toward the front of the machine so that its bottom peripheral edge is in line with the centerline of the tailstocks. The alignment of this face is facilitated by tilting the wheelhead (when possible) to place this beveled side of the saucer wheel in the vertical plane. See more B1070 information on page 53

III. GRINDING A FORMED CUTTER WITH RADIAL RAKE

A. Repeat all steps in part I, except C which should be modified as follows:

1. Before attempting to move the machine crossfeed from its position which leaves the tailstock centers in alignment with that of the wheel face, check the cutter side to see if it is stamped with the amount of "off-set" in the horizontal plane which will create the desired rake. Move the crossfeed in (POSITIVE "UNDERCUT" RAKE) the required number of thousandths of an Inch. Now reset the machine crossfeed dial to zero to be able to return to this correct rake setting.
2. If the cutter is not stamped with the amount of horizontal off-set from the center of the cutter, continue with

***NOTE:** on B360, BA960, B2060 Series, it is easier to mount toothrest if C955PC Dovetail Clamp is used.

step C by moving the crossfeed until it is possible to mount the cutter with its arbor between centers. Visually align the face of a tooth with that of the wheel until they are in the same vertical plane. At this point, reset the crossfeed index dial to zero.

3. Continue with step D without further adjustment of the crossfeed except for the initial trial run as explained in step F of I.

IV. GRINDING A FORMED CUTTER WITH BOTH AXIAL AND RADIAL RAKE

Follow all steps in part I above modifying steps B and C in succession as explained in parts II and III.

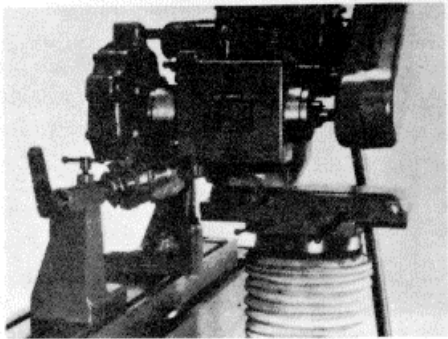


PHOTO 41

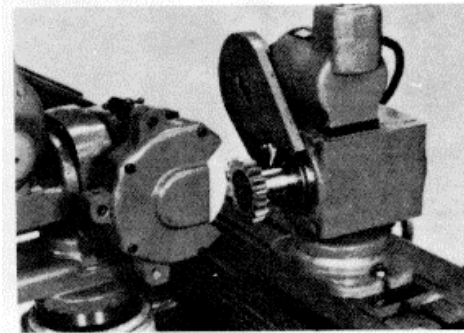


PHOTO 42

V. GRINDING THE BACK OF THE TEETH ON FORMED CUTTERS

- A Follow the procedures established in part I with the following exceptions: In step B, make any adjustment for axial rake that is necessary as described in part II. In step C, mount the cutter so that the tooth back to be ground faces toward the rear of the machine allowing it to be aligned with the vertical plane of the wheel. See Photo 41. This will create a set-up so that in step D the toothrest will index (hold) on the accurate ground FACE of the tooth. After alignment, set the crossfeed index dial at zero.
- B In general follow the same procedure as given in I, E, and F. Do not make any adjustments for radial rake on the crossfeed. While holding each tooth firmly against the toothrest, grind the backs of all teeth in succession until they appear uniform. Use a final light cut without attempting to "spark out."

VI. SHARPENING A FELLOWS GEAR SHAPER CUTTER

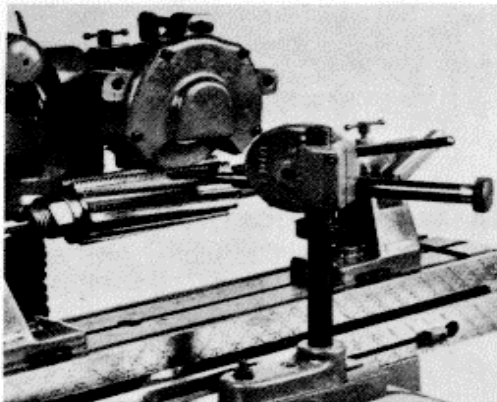
This cutter, being a formed type with cutting action perpendicular to the peripheral gear form, must be sharpened on its face or cutting side by means of cylindrical grinding.

- A Place the cutter on a stub arbor (such as a shell end mill and cutter arbor) in a motorized workhead, and place the workhead on the table in relation to the wheel as shown in Photo 42. Set the workhead spindle speed for low R.P.M. Mount a straight wheel on the grinder spindle and place the

spindle parallel to the grinder table. Select the necessary pulleys and belt to achieve the correct S.F.P.M.

- B. Position the axis of the workhead spindle at 85 degrees to the table travel, as shown in the photo This will duplicate the original 5 degree rake of the cutter. The workhead spindle should be set to 0 in the vertical plane. Move the table far enough to the right to bring the periphery of the wheel near the edge of the arbor washer. Set the left end table stop to limit further travel to the right.
- C. Move the table far enough to the left to allow the dresser to be placed on the table. True and dress the wheel. This should be done prior to rough grinding and once again prior to a final finishing pass, if the cutter was so dull as to necessitate heavy stock removal Roughing cuts should be no more than .002 inch, while finishing cuts should be as low as 0001 inch.
- D. Start the wheel motor in the "forward" direction and start the workhead spindle in the "reverse" direction The cutter and wheel, rotating at angles to each other, must move in opposite directions Move the cutter with the crossfeed to a point where it contacts the wheel, while moving the cutter face back and forth with table traverse. When no dull cutting edges show on periodic inspection, take the finishing light pass.
- E. Remove the cutter from the arbor and workhead and check the face rake angle.

NOTE: If the B1070 Spiral Grinding Fixture has been purchased the following general setups as to fixture, cutter and toothrest location will be applicable. Procedure for use of the Micrometer Toothrest is the same as discussed in Section II and III of this chapter.



B1070 SPIRAL GRINDING FIXTURE

Wide finger blade rests against rear of formed cutter flute, and has micrometer adjustment graduated 001", making it possible to roll cutter without moving machine crossfeed. Unit has a height setting collar for fast swing away from work.

CHAPTER 10**Grinding Cutters with Spherical Ends or Corner Radii****INTRODUCTION TO THE FIXTURE**

(LETTER DESIGNATIONS REFER TO PHOTOS 43, 44, and 45, NUMBERS ARE FROM FIGURE 45A.)

The Radial Grinding Fixture is a precision bearing instrument for generating convex or concave radii on cutting tools. By means of its own crossfeed (A) and longitudinal (B) feed screws which control the corresponding Lower Slide (35) and Upper Slide (52), work held in various fixtures can be positioned ahead or back of the Pivot Point Vertical Axis of the fixture in order to grind predetermined convex or concave radii. This pivotal axis is identified by the vertical edge of the knife Center Gauge (see Photo 43) or intersecting surfaces of the 'V' Center Gauge wheel either is positioned in the self-locking taper of the Pivot Stud (49) after removal of the Cap for Center Gauge (40). The feed screw dials are graduated in thousandths-050 inch to a revolution of the handwheel and are adjustable for desired 0 settings. Since the Saddle (50), on which the fixture bearing rests pivots around a vertical axis on a horizontal plane, it is possible to tilt by means of Adjusting Screw (4) the whole fixture back away from the wheel a fixed number of degrees for the purpose of setting clearance directly on the end of a cutter. The extent of the circumference of radius that can be generated is unlimited as the Fixture Turn Table (41) can be swiveled 360 degrees (RELATIVE TO THE SADDLE) about the Pivot Point Vertical Axis when the Table Adjusting Screws (E) are removed. The Turn Table (41) is calibrated in degrees. The Upper Slide and Lower Slide of the fixture can be locked by tightening their Gib Lock Screws (D). A Lever Arm (F) is provided to tilt the fixture further away from the wheel during the grinding process to allow indexing of the cutter or observation of grinding results.

OPERATING INSTRUCTIONS

Three typical set-ups using the Radial Grinding Fixture are presented below to acquaint the operator with its great versatility. Set-up photos show the radial fixture on the B6062 model grinder, however, it can be mounted on any of the other grinders. When it is mounted on the B300 or B360 grinder series, no cutter larger than 4 inches in diameter should be mounted on either the BA985 or the BA986 fixture. The BA985 fixture will mount cutters up to 12 inches in diameter on machine of model size BA900 and larger, however the maximum diameter for these machines is reduced to 9 inches when the BA986 fixture is in use.

I GRINDING A CORNER RADIUS USING BA985 RADIAL GRINDING FIXTURE

- A. Mount the BA985 fixture in approximately the center of the table, with spring-loaded locking screws and nuts (NUMBERS 42, 43, and 38) facing to the rear of the table slide, as shown in Photo 46. Secure the fixture to the table with two A657 T-slot bolts. Mount either a flared cup wheel or straight wheel at the left end of the spindle. Grind against a small edge on the face of a cup wheel; grind on the periphery of a straight wheel.
- B. Remove the Cap for the Center Gauge (40) and install the knife Gauge (B985G) if the cutter has no corner radii, or install the optional 'V' Gauge (B985J) if it already has corner radii. The crossfeed of the machine should be out far enough from the wheel so that the Gauge stands in front of the cup wheel or straight wheel. NOTE: See alternate radius locating procedure, page 63.

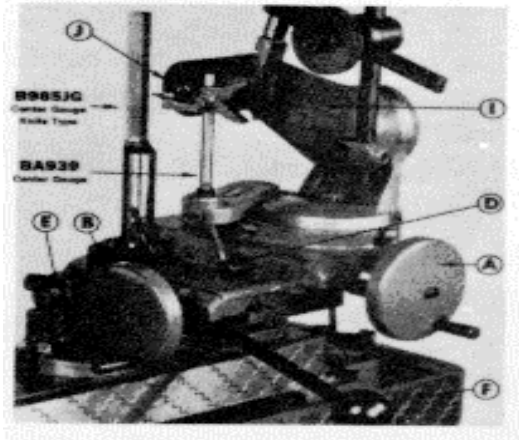


PHOTO 43

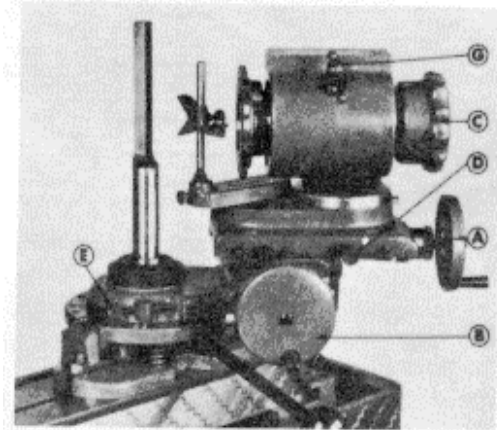
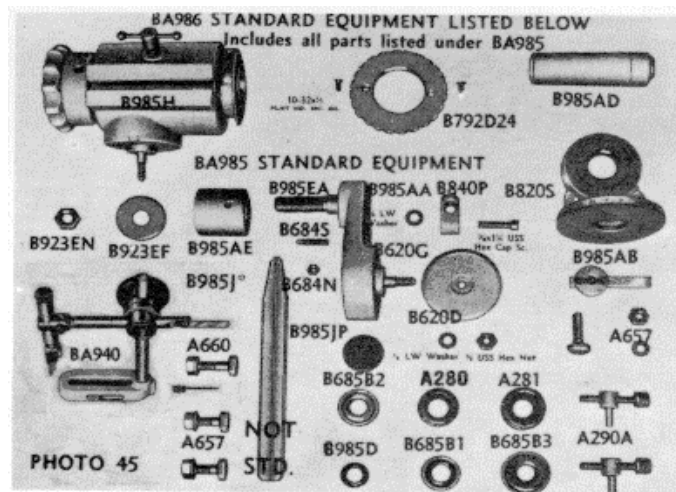


PHOTO 44



BA985 RADIAL GRINDING FIXTURE STANDARD EQUIPMENT

A280 Friction Collar, **A281** Friction Collar, **A290A** Table Adjusting Screw, **A657** **A660** T-Slot Bolts, **B620D** Back Plate, **B620G** Swivel Stud, **B684N** Nut, **B6845** Diamond Screw, **B685B1** 1/8" Cutter Bushing, **B685B2** 1" Cutter Bushing, **B685B3** 1 1/2" Cutter Bushing, **B820S** Swivel, **B840P** Swivel Block. **B923EF** Keyed Wheel Flange, **B923EN** Special Nut, **BA940** Tooth Rest, **B985AA** Swinging Arm, **B985AB** Swivel Index Bar, **B985AE** Diamond Holder, **B985D** Guide Bushing, **B985EA** Stud 3", ***B9851** (optional) Center Gauge, **B9851P** Cap (**BA939** Center Height Gauge, **B985JG** Center Gauge, Knife Type, are shown in **BA985** photo upper left) Net Weight 51 lbs.

BA986 RADIAL GRINDING FIXTURE STANDARD EQUIPMENT

Includes all equipment listed for BA985 Model and the following: **B792D24** Index Disc, **B985AD** Diamond Holding Arbor, **B985H** Housing and Spindle Assembly.

AVAILABLE EQUIPMENT

B792D Index Discs 4, 6, 8, 20, 24, 28, 30, 32, 34, 36, 38, 40, 42, 44, 48, 52, 54, 56 divisions available **B941** Collet Fixture, **B641C** Collets for B941 Fixture. Available sizes p6" to 1" by 64ths, 1/64" to 11/64.4" by 64ths **B641K** Straight Sleeves Available sizes IXs', 1Y", 1.6" and 14" **B642K** No 11 B & S Adaptor with Standard Milling Machine Taper Socket for holding B & S Cam Lock Tapers Available in taper Nos 10, 20 and 30 **B642T** Adapter Sleeves Available sizes Morse 1, 2, 3 and 4, B & S 5, 7, 8, 9 and 10 **B844E** 6" 4-jaw Independent Chuck mounted on No 11 B & S Arbor **B944** Adjuster tru 4" 6-Jaw Chuck mounted on No 11 B & S Arbor **B946** 4" 3-Jaw Universal Chuck mounted on No 11 B & S Arbor

BA985 and BA986 RADIAL GRINDING FIXTURES

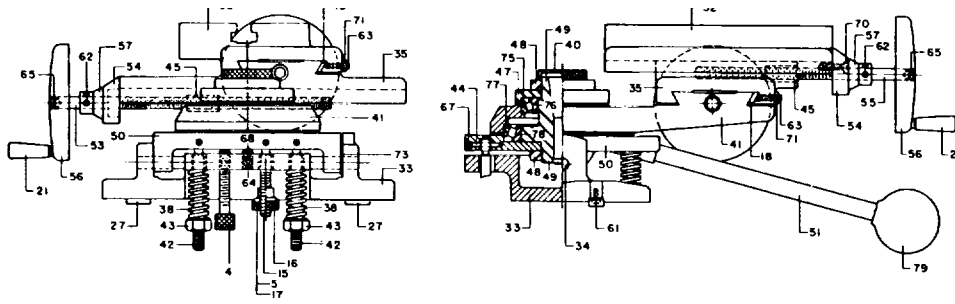


Figure 45A.

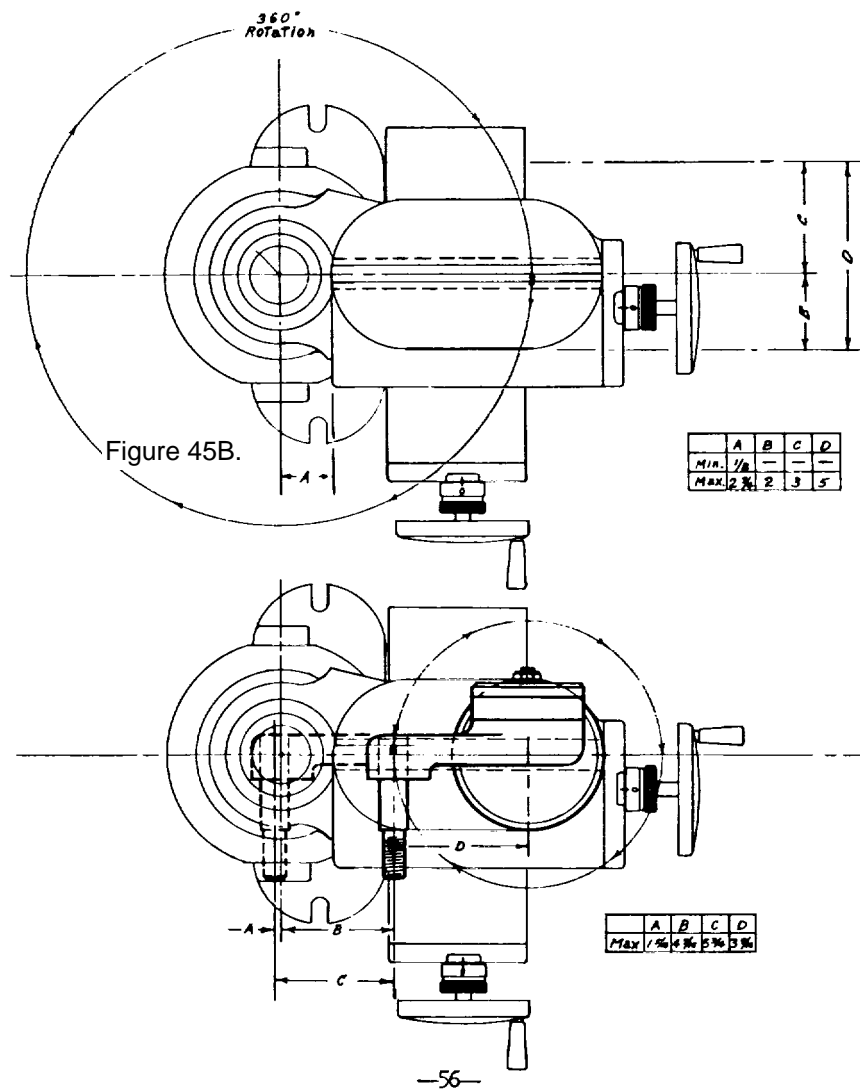


Figure 45C.

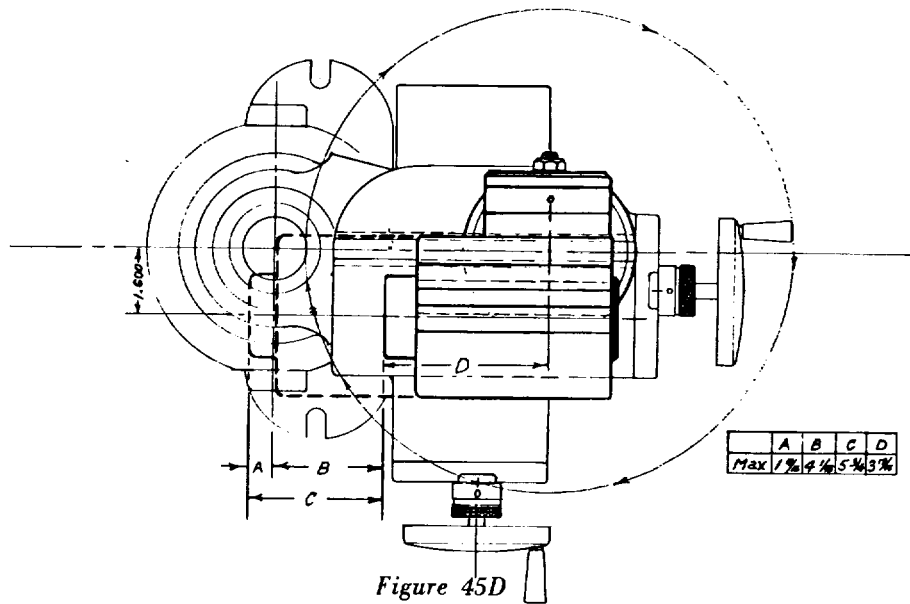


Figure 45D.

C Mount the cutter with peripheral cutting edges facing up as shown in Photo 46, or down if space permits a toothrest set-up from below. Mount the Swinging Arm (1) and lower swivel (H) on the fixture Upper Slide so that the cutter teeth, when mounted on the 4 inch Stud (1), will be just short of the Pivot Axis. Lock the swivels and tighten the cutter on the Stud with the appropriate size of Friction Collar and Washer (B923EF) and Nut (B923EN) so that it can just be rotated about the Stud.

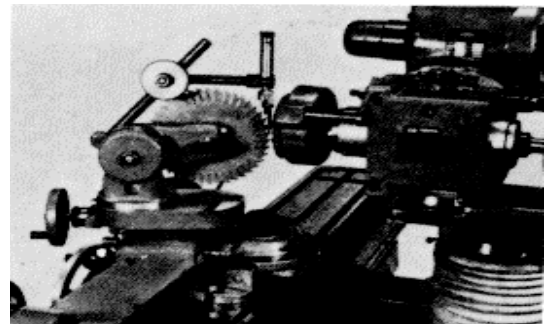


PHOTO 46

D Mount the Universal Toothrest (BA940), shown in Photo 46, if cutter edge faces up at the point of grinding. Use the B620G Swivel Stud as shown. Use the spring-loaded micrometer so that the cutter can be rotated to bring a new tooth on centerline with the cutter center by placing the BA939 Height Gauge on the Upper Slide as shown in Photo 43.

On tilthead grinders, the clearance for both the periphery and side may be taken directly by tilting the wheelhead. If the clearance is to be common, if more clearance is needed on the periphery than on the side teeth, create slide clearance by tilting the fixture Saddle (50) the desired amount for side teeth (FIXTURE IS CALIBRATED IN 5 DEGREE INCREMENTS), but add an additional amount for the periphery by checking the amount to rotate the cutter about its Stud mount from Tables I, II, and V on pages 104, 105, 107. In the latter situation, the wheelhead tilt should be set at 0 degrees. When the fixture is employed on a non-tilthead grinder, equal clearance for the side and periphery can be taken by tilting the fixture Saddle. Unequal clearance should be handled as explained above.

E Position the left edge of the cutter teeth against the edge of the Center

Gauge by means of Lower Slide handwheel(B)Position the periphery of the cutter (TOOTH ON WHICH THE CUTTER IS BEING INDEXED) against the edge of the Gauge by means of the Upper Slide handwheel (A)

- F. Reposition the Pivot Point Vertical Axis of the fixture "into" the cutter if a convex radius is to be generated, or locate this imaginary vertical axis out away from the cutter end If the radius to be generated is concave. Repositioning is done in the following manner'.

EXAMPLE: A 250 inch convex radius is to be placed on both corners of each tooth of a side milling cutter.

1. In the previous steps, the cutter side and periphery have been so positioned relative to the Pivot Point Vertical Axis that a line drawn along each now Intersects this axis. Remove the Center Gauge and replace the Cap (B985JP) Loosen the fixture Gib, lock the screws (D).
2. Set the Index Collar dial (57) at handwheel (B) at 0, and then turn this handwheel in a clockwise direction a total of 250 Inch (FIVE COMPLETE TURNS), moving the Lower Slide to the right. Tighten the Lower Slide Gib Lock Screws
3. Loosen the Upper Slide Gib Lock Screws Set the Index Collar dial (57) at handwheel (A) at 0 and then turn this handwheel clockwise a total of 250 Inch, moving the fixture Upper Slide In towards the wheel Tighten the Upper Slide Gib Lock Screws **NOTE:** If the radius on the end of the cutter is to be convex, the handwheels In B and C above would be turned in the opposite direction
4. At this point, move the side and periphery of the cutter against the right edge of the stationary wheel by means of the crossfeed on the machine When one side or cutting edge of the cutter tooth on which the radius is to terminate touches the wheels (USE A THIN PIECE OF PAPER AS A FEELER GAUGE), set the machine crossfeed dial at 0 Set a fixture stop (E) to limit rotation of this edge of the cutter clockwise Now back the machine crossfeed away from the wheel enough to allow the cutter to be rotated counterclockwise In order to bring the other cutter edge against the wheel by means of the machine crossfeed, checking to see that the machine crossfeed dial comes back to Its 0 setting If it does .not, the convex radius was not properly set on the fixture, and the cutter should be tested again with the Center Gauge Set a final fixture stop (E) to limit the counterclockwise rotation
5. Back off the machine crossfeed far enough so that the corner edge of the cutter may be positioned at the wheel edge and the fixture rotated at this point Start the wheelhead motor Continue swiveling the fixture from side to side while advancing the machine crossfeed When the crossfeed dial shows 0, plus the thickness of the feeler gauge, the desired radius should be achieved It is well to check the grinding results somewhat ahead of the final crossfeed amount by tilting back the fixture base with lever (F). All teeth should be roughed out first, leaving a small amount for finish grinding **NOTE:** Unless the alternate method of using the radial fixture (described in Section IV D1 is employed, it is important not to change the setting of the fixture Upper Slide and Lower Slide. In the method just described, the final correct radius is created by slowly bringing the fixture Pivot Point Vertical Axis into a vertical plane that is no further away from the wheel face than the radius set on the fixture.

If the radius to be generated is concave, then the final correct radius is created by slowly advancing the machine crossfeed to a point where the Pivot Point Vertical Axis is "into" the wheel by the amount equivalent to the radius. Further advancement of the machine crossfeed will decrease a convex radius and increase a concave one.

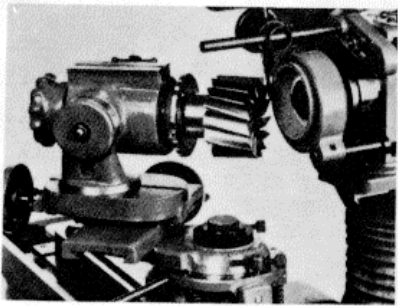


PHOTO 47

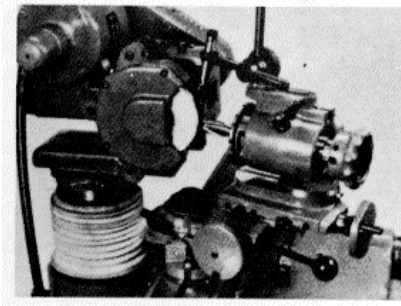


PHOTO 48

- G If the cutter has a steep helix or if for some other reason it is desirable to attach the toothrest to the wheelhead of the grinder (see Photo 47), the above set-up will still apply. Lever (F) can still be used to back the cutter tooth away from the wheel. In order to index the cutter for the next tooth to be ground without moving the machine crossfeed, the grinding wheel rotation should be in the direction that holds the tooth against the toothrest. During the grinding process, it may be necessary to compensate for wheel wear by slight movement of the machine crossfeed.
- H Repeat the above steps for the radii on the left corners, working from the left edge of the wheel.

II. GRINDING A CORNER RADIUS USING BA986 RADIAL GRINDING FIXTURE

EXAMPLE: Generating a radius on the flute ends of a spiral end mill

- A Initial set-up is accomplished as follows:
- 1 Mount the fixture on the grinder table as in A-1, and 2, with the Upper Slide (52) set parallel with the grinder table and the Saddle (50) set at 0 degrees tilt.
 - 2 By means of the B820S swivel, place the B985HHousing and Spindle Assembly on the fixture Upper Slide in a convenient position and lock temporarily with a 'T' slot bolt. Install the cutter shank into the Spindle Assembly by means of the B941 Collet Fixture and an appropriately sized B641C 5C Collet, if possible. For cutters with straight shanks larger than 1 inch, B641K straight sleeve adapters can be used to mount the cutter. In the spindle, if the cutter has a tapered shank, use a B642T taper adapter sleeve.
 - 3 Locate the Spindle Assembly and cutter up to just short of the Center Gauge and lock the lateral swivel at 90 degrees and the vertical swivel at 0 degrees.

- B. If the cutter helix is not too steep or the radius too large, mount the Universal Toothrest on the fixture in the manner described in I-D, except that the base of the BA940 toothrest will be placed on top of the B985H Housing and Spindle Assembly or on the Table of the fixture similar to the set-up in Photo 46. The teeth cutting edges will be faced up at the point of contact with the wheel, as in Photo 47, and the spindle lock (G) tightened with one tooth against the blade. If the cutter has a very steep helix and the radius to be ground is rather large, it may be necessary for the toothrest to be attached to the wheelhead, because in this position the flute end will be in a position to follow the toothrest blade (BY ROTATION OF THE SPINDLE ASSEMBLY) when the fixture is rotated about the Pivot Point Vertical Axis. In either case, if equal clearance is to be taken on both the periphery and the face of the cutter, set the toothrest by means of the Height Gauge so that the tooth face edge is on center with that of the Spindle Assembly.
1. For equal clearance on the periphery and the face, set the clearance for the tooth indexed by turning the Table Adjusting Screw (4) in a right-hand direction, reading the degrees on the dial of the fixture base.
 2. If less clearance is desired for the end or face of the cutter than for the periphery, the cutter may be rotated by adjusting the micrometer toothrest enough to equal the ADDITIONAL amount of clearance desired over that already taken on the fixture itself. (See I-D). If the toothrest is on the wheelhead, the cutter may also be rotated up by simply raising the wheelhead the required amount.
 3. On tilthead grinders it is possible to create the necessary clearance on the radius by tilting the wheelhead if the toothrest is mounted on this type of head (see Photo 47), then all the clearance must be of a common angle, and the blade end should be on center with the cutter center.
- C. Continue the set-up by positioning the cutter edges against the Center Gauge, as in I-E, so that the lines drawn along the face and the peripheral edges of the cutter intersect the Pivot Point Vertical Axis of the Gauge. NOTE See alternate radius locating procedure, page 63.
- D. Remove the Gauge and move the fixture handwheels as described in I-F. In order to relocate the Pivot Point Vertical Axis relative to the cutter to produce the desired convex or concave radius. Grind the cutter as described in the same section.
- E. If the toothrest has been placed on the wheelhead, read I-G.
- F. Always sharpen the periphery of a milling cutter. If necessary, prior to creating the radius. This may be done as described in Part III.

III. USE OF THE RADIAL GRINDING FIXTURE FOR SHARPENING THE PERIPHERY OF A HELICAL CUTTER

- A. When using the BA986 fixture, holding a cutter with a helix as in Photo 47, position the B985H Spindle perpendicular to the axis of the grinding wheel spindle (PARALLEL WITH THE MOVEMENT OF THE MACHINE TABLE). This is done by putting its swivel base on the 90 degree setting, locking the swivel, and then swinging the fixture counterclockwise to a point that will align the Upper Slide of the fixture with the grinding machine table. Stops (E) are then set to hold the fixture rigidly in this position. It will be necessary to use a dial indicator on the mounted cutter or on a test arbor mounted in the B985H in order to determine parallelism with the table travel.

- B. Locate the toothrest on the right edge of the cup wheel (OPPOSITE TO THE POSITION AS SHOWN IN PHOTO 47) and attach to the wheelhead
1. **On non-tilthead grinders**, put the toothrest blade end on center with the B985H spindle center or cutter center. Consult table II, page 105, for amount to raise the wheelhead
 2. **On tilthead grinders**, tilt the wheelhead to the desired clearance angle and then place the toothrest on the wheelhead, blade end on center with the cutter center
- C. Proceed to sharpen the periphery as described in the chapter on end mills

IV. SHARPENING OR CREATING BALL END MILLS* (EXPLANATION IS FOR RIGHT-HAND END MILLS)

- A. Mount the cutter as described in II-A and shown in Photo 48.
- B. Positioning the cutter relative to the fixture Pivot Point Vertical Axis:
1. With the knife Center Gauge installed, make contact with the left side of the cutter periphery
 2. Remove the Center Gauge and turn the handwheel (B) counterclockwise an amount equivalent to one-half the diameter of the cutter. Tighten Lock Screws (d) on the Lower Slide
 3. Turn the fixture handwheel (A) counterclockwise enough to bring the Upper Slide back far enough from the Pivot Point Vertical Axis to allow the Center Gauge to be inserted again just beyond the end mill position the end of the mill against a face of the Gauge Remove the Center Gauge and tighten the Lock Screws (F) for the Upper Slide Replace the Cap for the Center Gauge
 4. Turn the fixture handwheel (A) clockwise an amount equal to one half the cutter diameter-or that of its ball end.
NOTE: See alternate radius locating procedure, page 63
- C. A ball end mill will necessitate mounting the toothrest on the wheelhead as shown in Photo 47, thus allowing the helical flutes to follow the fixed blade The blade must be shaped to allow it into the narrow ends of the flutes In order to clear other teeth than the one being ground, the use of a straight wheel will usually be necessary Place the blade at the middle of the wheel width With a straight wheel, all clearance will be generated by the periphery of the wheel when a micrometer toothrest blade is placed over the wheel and on center with it Determine the amount to raise the blade (BY MICROMETER) from Table I, page 104Finally, raise or lower the wheelhead to position the toothrest blade at the cutter center When a straight wheel is used, no additional clearance need be taken on the fixture or its Spindle Assembly. Place the end of the mill In relation to the toothrest so that one flute catches the blade but does not touch the wheel Experimentally rotate the fixture through an arc of 90 degrees counterclockwise while holding the fixture spindle hand- wheel(C) with clockwise pressure The ball end mill flute should follow around the toothrest blade without binding or bending the blade. Set fixture stops (E) for a swing of slightly less than 90 degrees counterclockwise from center. Center the cutter on the toothrest and set the machine table stops to keep it from moving right or left.

*Fixture may be difficult or impossible to use with end mills smaller than 2" diameter and/or those with very steep helix

D. Sharpening Process:

NOTE: This infeed process can be used for any cutter whose radii are already formed and whose radius can be centered on either one of the fixture slides; this one slide becomes the only infeed moving the work relative to the wheel.

1. With the center axis line of the cutter directly in line with the high point of the toothrest blade, move the crossfeed in slowly until the cutter end just avoids the wheel.
2. Start the wheelhead motor, and with the cutter axis perpendicular to the wheel periphery, lightly advance the machine crossfeed while holding the cutter against the toothrest with the handwheel (C) When the first sparks appear, stop the machine crossfeed and slowly rotate the fixture and the Spindle Assembly to follow one spiral flute through its arc swing to the left until the fixture stop is contacted
3. Use the fixture tilting lever (F) to move the cutter away from the toothrest for examination of the grind If the tooth land has been contacted uniformly, rotate the Spindle Assembly until the flute 180 degrees opposite the one just ground is available, and after returning the fixture to the center starting position, slowly release the lever until the new flute land contacts the wheel. At this point, immediately begin to rotate the fixture through its arc swing again, always holding the flute face firmly against the toothrest After the first acceptable contact of the first flute with the wheel, the machine crossfeed must not be moved as doing so will destroy the true radius now established between the Pivot Point Vertical Axis and the periphery of the wheel
4. After the first acceptable contact with the two flutes 180 degrees opposite each other on the cutter, all additional teeth should be contacted. At this point, Infeed the fixture handwheel (A) 001 inch, sharpening all teeth prior to the next infeed on the fixture
5. All flutes should be rough ground, finishing with a final light cut on the primary land If a secondary clearance appears necessary, it is produced by further adjustment of the micrometer toothrest above the wheel center and a consequent lowering of the wheelhead to put the blade on center with that of the cutter. At the end of the flutes, it will be necessary to finish gashing by a hand operation.

V. OTHER USES OF THE RADIAL GRINDING FIXTURE

A Forming Radii on the Grinding Wheel

1. The diamond nib can be installed on either the Diamond Holder (B985AE), which is in turn Installed on the Stud (J) of the BA985 Fixture, or It can be put into the B985AD Diamond Holding Arbor, which is in turn seated into the taper of the B985H Spindle Assembly
2. Mount the Center Gauge into the fixture Pivot Stud (49).
3. Using the fixture Upper Slide and Lower Slide, bring the diamond point to the exact Pivot Point Vertical Axis of the fixture. Remove the Gauge and replace the Cap
4. Raise or lower the wheelhead of the grinder until the diamond point is at the wheel spindle center. The diamond point should also be centered in the middle of the wheel width If the radius is to be centered on the wheel periphery.
5. Using EITHER the fixture Upper Slide OR its Lower Slide, position the

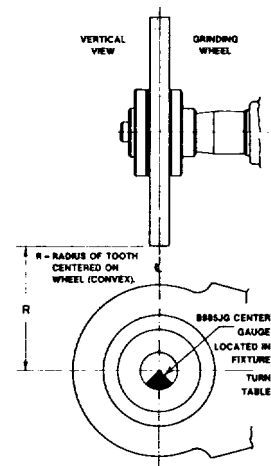
diamond point beyond the Pivot Point of the fixture if a concave radius is desired in the wheel, or position the diamond point back of the Pivot Point to create a convex radius Do not attempt to use both of the fixture handwheels to reposition the diamond point relative to the Pivot Point.

- 6 Using fixture stops (E), set the required arc swing of the fixture.
 7. Begin to form the wheel with the diamond by advancing the machine crossfeed while swinging the fixture through a predetermined arc It will often be possible to measure the amount of total infeed of the nib into the wheel by means of the machine crossfeed dial Measure the amount of the radius after the point strikes the wheel (FOR A CONCAVE RADIUS), or after the Gauge edge contacts the wheel (FOR A CONVEX RADIUS).
 - 8 If the convex radius is to be tangent to the side and periphery, it will be necessary to measure the radius distance in from the wheel side and set the grinder table stops
 9. If optical observation is involved, no measuring of crossfeed on the machine will be necessary as infeed into the wheel will take place until the formed radius conforms to the template on the observation scope.
- B Radius work on the corners of face mills up to approximately 10 inches diameter can be accomplished on the radial grinding fixture with the addition of the B992 Workhead mounted on the fixture Upper Slide This workhead, having a standard taper of 50MM, may be adapted to 40MM taper or to B & S No 11 taper.
- C. Form tools and chip breakers can be held by the B989 Universal Workholding Fixture which can be mounted on the radial fixture Upper Slide.

ALTERNATE PROCEDURE FOR CUTTER RADIUS LOCATION:

PIVOT POINT VERTICAL AXIS RELATIVE TO THE GRINDING WHEEL

- 1 Insert the B985JG center gauge so that the flat of its "V" is positioned toward the peripheral edge of the grinding wheel. Line up the center of the wheel face and tooth radius with the center line of the center gauge, lightly touching a feeler gauge placed between the center gauge and the wheel. NOTE: Never touch the grinding wheel against the center gauge Use a known size feeler gauge such as shim stock, for which crossfeed dial can be compensated. 2 Set the desired radius by moving the machine cross- feed handwheel (nor the fixture slide), thus locating the fixture pivot point axis the correct distance from the wheel. A concave radius can only be set by re- moving the center gauge first. Eliminate backlash in the machine crossfeed when setting the radius dis- tance by making the final adjustment of the machine saddle toward the wheel Saddle lock may be lightly applied, but always verify the final radius distance
- 3 After the correct radius is established, use the slides of the fixture to blend the radius to the cutter. Usually the upper slide handwheel "A" will be used to feed the cutter into the wheel for stock removal. The crossfeed of the grinder must not be moved, as this will change the radius. See diagram above.
4. Proceed with grinding as in IV-D, 4, 5.



CHAPTER 11

Reamers

A reamer is a cutting tool combining economy and accuracy for enlarging holes to a required diameter. Reamers cut their way into holes with their leading edges and produce a smooth finish while cutting to size.

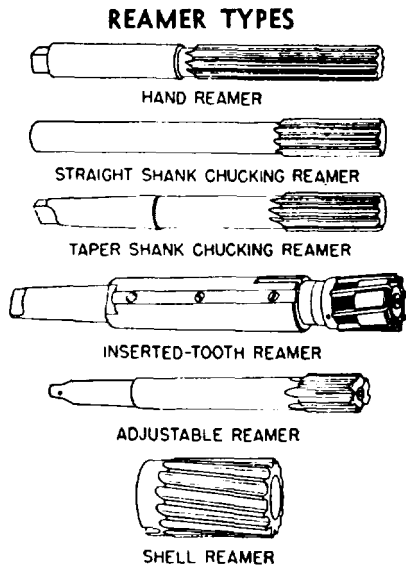


Figure 49A.

Most reamers fall into the following general categories: hand reamers, straight shanked and taper shanked machine or chucking reamers, adjustable or expansion reamers, inserted tooth reamers, and shell reamers. Figure 49A shows the general types of reamers. Reamers may have tapered flutes for tapered holes and may also have spiral flutes, straight or tapered in size.

With the exception of grinding the chamfer or leading taper, all solid reamers are reduced in size when their blades are ground on the periphery. With these reamers, when the peripheral cutting land has become dull at the cutting edge or where other reasons dictate, a cup wheel is used and the reamer is reduced to the next smaller usable size. Since most dullness occurs at the lead cutting edges, most sharpening consists of grinding only the chamfer or lead taper.

In many instances, especially with expansion or inserted tooth reamers, it is desirable to cylindrically grind the

periphery and then "back-off" a secondary cutting clearance or relief land behind the circular land, leaving a narrow non-relieved convex land or "margin" just in front of this relief. Refer to Chapter 2 in this section for the general construction of reamers and their nomenclature.

Most clearance angles are critical on reamers, and it is therefore advisable to consult the reamer clearance charts (see tables III and IV, pages 106, 107) for the correct amount to raise or lower the wheelhead or micrometer toothrest. For this reason, the tilting wheelhead should not be used for grinding the lead taper or the periphery of these tools as the tilting degree scale cannot be read with sufficient accuracy. The table is a standard one used in many handbooks, but it should be understood that it is an approximation, as desirable margin widths and clearance may vary from the table with different materials to be reamed, the amount of material to be reamed, the size of the hole, and the manner in which the reamer is to be used. NOTE: Most manufacturers would probably agree with the .006 inch recommended as a margin for hand reamers for steel. It is possible, however, that the margin could go up to about .015 inch for some larger reamers of this class. If cylindrically ground, the margin width left after the cutting or secondary clearance is equivalent to the "Primary Clearance Angle" shown. The "Secondary Clearance Angle" is the only one applied in this case. When considering the margin widths recommended for other metals, some manufacturers claim the margin can go up to 50 percent over the table recommendations for cast iron.

and approximately 50 percent lower for stainless steel and Monel Metals. They may also recommend considerably narrower margins for soft metals such as bronze, brass, aluminum, magnesium, etc., on the order of .002 inch maximum. The apprentice or student is advised to duplicate the margin and clearance angle known to exist on the reamer when new.

I. GRINDING A HAND REAMER USED WITH STEEL

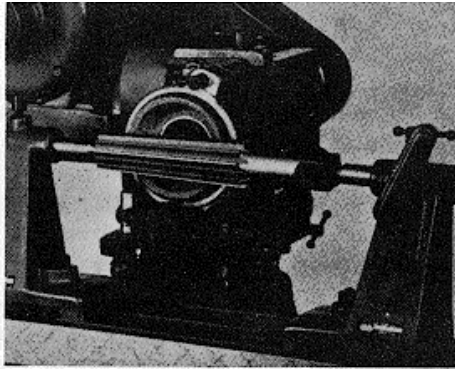


PHOTO 49

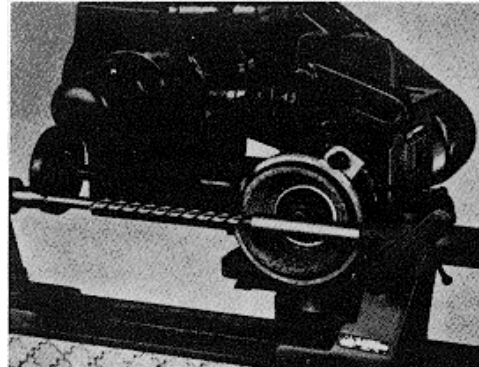


PHOTO 50

A Set-up Preparation:

1. Hand reamers are made in both solid and expandable forms. If adjustable, set out the blades up to .005 inch prior to mounting the reamer between tailstock centers.
2. If the reamer is to be used for finishing and an extremely smooth finish is desired, it should be cylindrically ground first in a conventional manner to obtain uniform size of all blades and to produce the long lasting convex margin between the cutting edges and the secondary relief. In this situation, the cylindrical margin becomes the "primary" relief. Consult Chapter 13 of this section for general instructions on cylindrical grinding. Continue to check the diameter of the reamer with a micrometer during the grinding process. When the reamer is to be used for large stock removal or just enlarging holes, a flat relief produced by a cup wheel is preferred because of its keener cutting edge. Obtain clearance angle settings from Table III or IV, pages 106 or 107.
3. Mount the flared cup wheel at the left end of the spindle, turn the wheelhead spindle to 91 degrees, and mount the cup wheel guard as shown in Photo 49. Dress the face of the wheel with the rotary wheel dresser to an angle of about 20 degrees and a cutting edge of about 1/6 inch in width.
4. Create a tailstock set-up similar to Photo 49, if the periphery of the flutes is to be ground. Create a set-up similar to Photo 50 if only the chamfer or lead taper is to be sharpened. In the latter case with a steep helix on the reamer, it may be necessary to put the toothrest on the wheelhead as shown in Photo 50. However, most of the time the universal toothrest should be attached to the table of the grinder to achieve accuracy and ease of operation.

B. Sharpening the Straight Periphery or Back Taper:

1. Assuming the above set-up conditions and that it is desired to grind with

only a cup wheel, check the portion of the teeth back of the chamfer or lead taper for any built-in back taper. This may be done with a hand micrometer, since "feel" will reveal tapers of .001 inch per inch or less. Set the reamer in place between the centers and locate a toothrest on the machine wheelhead (from above or below the wheel) and the blade on center with the center of the reamer. Adjust the swivel table to equal the known or desired taper on the reamer. If it is not possible to measure the small taper accurately, a guess will have to be made and the adjustments made when grinding the primary clearance or margin. The back taper is usually on the order of .001 inch per inch, but it may go as high as about .020 inch per inch, especially if it is not started immediately after the chamfer or lead taper.

2. Using the short adjustable micrometer with a rounded blade as shown in Photo 49 (or by raising or lowering the wheelhead), consult the clearance table mentioned above and "roll" the reamer up or down the required amount, depending on the position of the rest
 3. Start the grinding wheel motor and traverse the reamer while firmly contacting the toothrest. Care must be taken not to remove so much metal as to lose the final desired reamer diameter just back of the chamfer or lead table. It is desirable to contact the wheel very lightly with one tooth held firmly against the rest and then to grind the entire peripheral length of this tooth prior to checking or going to the next tooth. As each tooth margin is ground, it is necessary to continually check the diameter of the reamer. If a sizeable margin of .006 inch or larger must be left, it may not be necessary to use the secondary clearance. If a secondary clearance is needed to reduce the width of the margin created by sharpening, adjust the wheelhead or toothrest by the reamer table values and grind the secondary in the same manner as the primary land.
- C. Sharpening the Lead Taper:
1. Sharpen the lead cutting taper by shifting swivel table to the desired taper, usually on the order of $\frac{1}{4}$ inch to $\frac{1}{8}$ inch taper per foot. The length of the taper varies greatly with the length of the reamer, but it may cover as much as one-third of the total flute length. This taper starts immediately back of the lead chamfer if present.
- D. Sharpening the Chamfer:
1. The swivel table is usually set at 45 degrees, but the existing chamfer should be followed.
 2. Consult the reamer clearance tables for "Rose Chucking Reamers for Steel". Place reamer chamfer face on center with the center of the reamer by means of the toothrest, which is placed on the grinder table. Raise or lower the toothrest (or the wheelhead) the amount necessary for the angle desired. Grind the chamfer, holding the reamer firmly against the toothrest, by traversing the table while advancing the crossfeed. No secondary clearance is placed on the chamfer. NOTE: It may be faster to merely align the land width of the existing chamfer with the face of the grinding wheel in order to obtain an adequate chamfer relief. If the grinder has a tilting wheelhead, it is equally fast to center a tooth horizontally on the chamfer face with a rest and then tilt the wheelhead to the desired clearance angle.

II. GRINDING A HAND REAMER USED WITH CAST IRON, STAINLESS STEEL, AND MONEL METALS

Generally there will be a few exceptions to the above procedure for hand reamers for steel. The major difference will be final margin width left (primary relief) on the reamer front leading taper and the remainder of the blades back from this taper. As stated in the introduction, this figure can vary approximately from .012 inch for cast iron up to .038 inch for the Monel Metals depending on the size of the reamer and the specific metal involved.

III. GRINDING A HAND REAMER USED WITH SOFT METALS

The procedure will be the same as in Part I, except that the primary relief land is reduced to a "hair line" of no more than .002 inch for best results in most instances. This can be achieved by grinding the primary relief as suggested in the Table and then grinding a sufficient secondary clearance to reduce the primary land to the desired width. Experience will tell the correct margin to leave for the material being reamed.

IV. GRINDING A MACHINE OR CHUCKING REAMER FOR STEEL, CAST IRON, MONEL METALS, AND OTHER SOFT METALS

- A. The general grinding sequence is the same as discussed in Part I. Whenever possible (AND ESPECIALLY FOR USE WITH STEEL) it is desirable to cylindrically grind the margin of the reamer. These reamers, as is true with most reamers, have some amount of back taper (See Part I, B above.) Chucking reamers usually cut with the front chamfer, but a few cut with a slight lead taper. These portions of the reamer showing wear first need to be sharpened more often.
1. Fluted Chucking Reamers These reamers have either straight or tapered shanks, spiral or straight flutes, and are primarily used in turret lathes and screw machines for light metal removal. They have a gradual leading chamfer or taper, and the relief back of the cutting edge (rear point of chamfer) extends the full length of the land. Reproduce the lead taper when sharpening after grinding the relief on the periphery back of the cutting edge. Observe any back taper that may be present.
 2. Rose Chucking Reamers: Reamers of this class are used in the same machines as fluted chucking reamers, but they are designed for larger amounts of metal removal and thus do all of their cutting on the end chamfer, which is usually 45 degrees. If necessary, they should be cylindrically ground back of the chamfer with a back taper of not more than .001 inch per inch. There is no relief on the lands back of the chamfer. Use the reamer clearance tables and sharpen the 45 degree chamfer with the recommended clearance angle. (See Part I-D and refer to Photo 50).
- B. Observe the margin requirements where applicable as described in sections I, II and III of this chapter for the different types of metals which are to be machined.

V. GRINDING A STRAIGHT OR HELICAL FLUTE TAPER REAMER

- A. Taper reamers are sharpened leaving a very narrow or hair line margin. This margin requirement usually demands the use of a cup wheel and should not exceed .003 inch for the largest reamers. Use the clearance table for reamers.
- B. Use the same general procedure for sharpening as given in Part I above. The set-up is shown in Photo 51. The taper should be checked after grinding the first tooth even though the swivel table has been adjusted to the correct

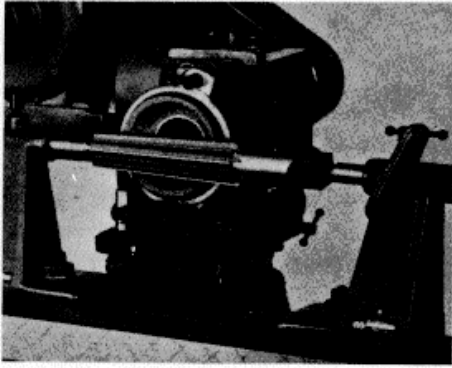


PHOTO 51

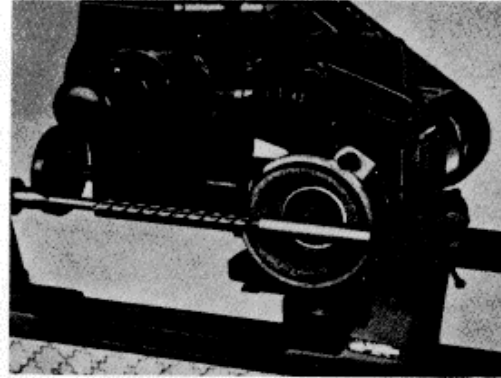


PHOTO 52

taper. This may be done by micrometer OD measurement or actual use of the reamer in a hole, by checking the hole reamed with a plug gauge

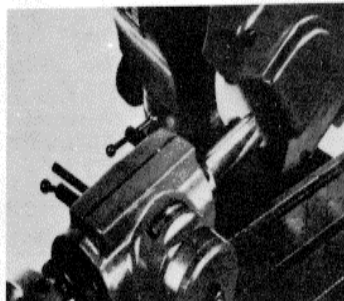
- C. When grinding a helical flute taper reamer, it is necessary to mount the universal toothrest on the wheelhead, as in Photo 51 or 52 Use the plain cross arm holder and rounded blade as shown. Hold the tooth being ground firmly against the toothrest blade and traverse the table while rotating the reamer. NOTE: A long center (Part No. B921RCL, Photo 52 is available to assist in sharpening long narrow reamers.

VI. CARBIDE REAMERS

- A. The chamfer on carbide reamers should be ground before much wear is apparent Usually sharpening consists of grinding the 45 degree chamfer with adequate relief. Consult the clearance tables for Rose Reamers. Table IV, page 107, gives the suggested peripheral relief angles for carbide using a cup wheel when the primary relief is to be ground. Occasionally, the radial faces of the blades near the cutting chamfer will need polishing to remove built-up metal. Cylindrical grinding of the peripheral lands is done only when absolutely necessary, as these reamers are usually made with circular ground lands on the periphery.
- B. Grind the peripheral lands by means of a thin diamond straight wheel. 220 grit, resinoid bond is suggested. The set-up is described in Chapter 13 on cylindrical grinding Observe the following modifications.
1. Dull edges of the circular land (MARGIN) cause the reamer to be forced through the hole without cutting properly-creating dimensional error Land width is important and will vary with the metal to be cut. Table IV, page 107, gives the suggested circular land widths for different materials After circular grinding, back off a secondary land using the general clearance suggestions in the reamer tables leaving a land width as stated in Table IV.
 2. Where these reamers are to be guided through bushings, sharpen the chamfer only and grind the body of the reamer .0002 inch to .0004 inch under the cutting diameter with no relief on the circular lands.
 3. Under some conditions when machining soft materials, a short (1/8 INCH MAXIMUM) 45 degree chamfer with a lead taper of 2 degrees (FROM 1/8 INCH TO 1/4 INCH LONG) should be used for best results. A secondary clearance is not necessary on the short lead taper.
- C. If the reamer is expandable and has been damaged, set the blades out sufficiently, and cylindrically grind it to the correct size.

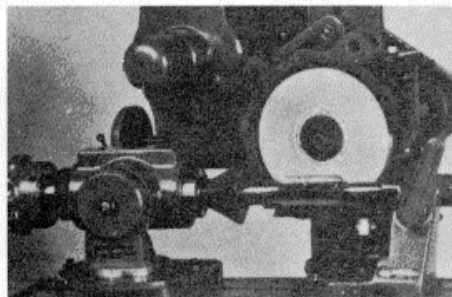
CHAPTER 12

Taps



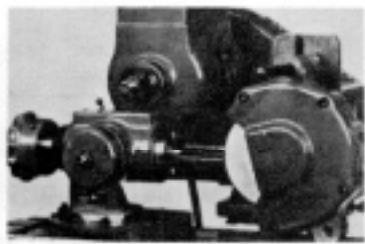
Sharpening a standard tap.

PHOTO 53



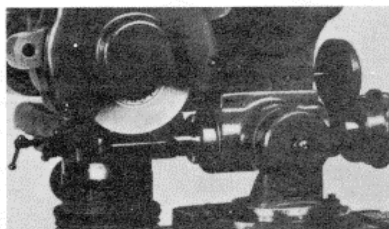
Sharpening a 2 1/2" tap.

PHOTO 54



Salvaging a broken tap.

PHOTO 55



Grinding the flute of a tap.

PHOTO 56

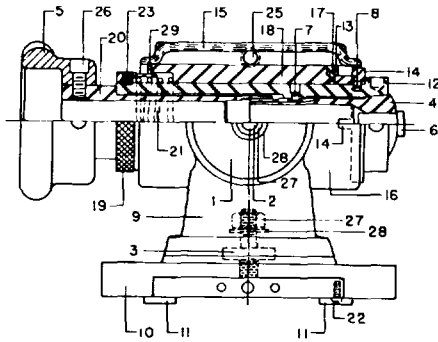
INTRODUCTION TO THE FIXTURE

The 1947 Tap Grinding Fixture is designed to accommodate taps from No. 0 size to 2/2 inches in diameter, two to six flutes, with available components. It is adaptable to any make of tool grinder and can be mounted on a surface grinding machine as well. The fixture has a horizontal and vertical swivel, graduated in degrees-90 degrees either side of center. The base swivel will allow 360 degree rotation, while the vertical plane swivel has a maximum swivel of 30 degrees either side of the center.

The fixture will sharpen taps, salvage broken taps, and reform taps for a specific requirement relative to the grinding of tap flutes, chamfer, and its clearance.

The fixture is designed with positive lift cams, appropriately stamped for the specific tap sizes and number of tap flutes each cam will serve. Index discs are easily identified and are selected to provide the number of lifts required to correspond to the number of flutes on the tap. With simple selection of the proper lift cam and Index discs components, the spindle action of the Tap Grinding Fixture is positive and ideal for the taps. The collets (B641C) used with this fixture are standard 5C collets, which can be utilized for other FIXTURES.

B947 Tap Grinding Fixture



STANDARD EQUIPMENT

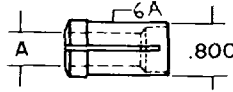
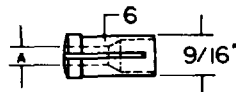
B641C	1/4 Collet	B647B 1/2	Bushing—Tap 1/2
B647B8	Bushing—Taps 7 and 8	B947C2	Flute 0 to 12 Tap
B647B10	Bushing—Taps 9 and 10	B947C2	Flute 12 and over Tap
B647B12	Bushing—Taps 12	B947C3	to 6 Flute 0 to 12 Tap
B647B 1/2	Bushing—Tap 1/2	B947C3	to 6 Flute 12 to 1/2 Tap
B647B 3/4	Bushing—Tap 3/4	B947C3	to 6 Flute 1/2 and over Tap
B647B 5/8	Bushing—Tap 5/8	B947C3	to 6 Flute 3/4 to 1/2 Tap
B647B 7/8	Bushing—Tap 7/8	B947D2	Index Disc (2 Flute)
B647B 1	Bushing—Tap 1	B947D3	Index Disc (3 Flute)
B647B 1 1/4	Bushing—Tap 1 1/4	B947D4	Index Disc (4 Flute)

AVAILABLE ACCESSORIES

B641C800	.800" Collet to fit 1" Tap	B947CL2	Flute 0 to 12 Tap
B647F	Bushings for B641C800 Collet to fit 1/4", 3/8" and 1/2" Taps	B947CL2	Flute 12 and over Tap
B647B	Bushing Taps 0 to 6 incl.	B947CL3	to 6 Flute 0 to 12 Tap
B647P	Driver for Taps over 1"	B947CL3	to 6 Flute 12 to 1/2 Tap
A261C	Spring Center, B821 or B922R	B947CL3	to 6 Flute 1/2 to 3/4 Tap
	Tail Stock must be used with B647P.	B947CL3	to 6 Flute 3/4 and over Tap
		B947D5	Index Disc (5 Flute)
		B947D6	Index Disc (6 Flute)

Index No.	Part No.	Quan. Req.	Description
1	B620D	1	Back Plate
2	B620G	1	Swivel Stud
3	B620R	1	Base Stud

Index No.	Part No.	Quan. Req.	Description
4	B641C	1	Collet 1/4"
4	B641C800	1	.800" Collet to Fit 1" Tap
5	B641H	1	Hand Nut

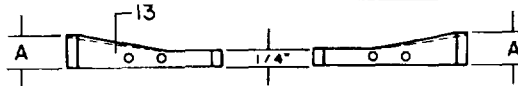


Index No.	Part No.	Quan. Req.	A Size	Description
6	B647B6	1	.140	Bushing—Taps 0 to 6
6	B647B8	1	.168	Bushing—Taps 7 and 8
6	B647B10	1	.194	Bushing—Taps 9 and 10
6	B647B12	1	.220	Bushing—Tap 12
6	B647B 1/2	1	.255	Bushing—Tap 1/2
6	B647B 3/4	1	.318	Bushing—Tap 3/4
6	B647B 5/8	1	.381	Bushing—Tap 5/8

Index No.	Part No.	Quan. Req.	A Size	Description
6	B647B 1/4	1	.323	Bushing—Tap 1/4
6	B647B 1/2	1	.367	Bushing—Tap 1/2
6	B647B 3/4	1	.429	Bushing—Tap 3/4
6	B647B 5/8	1	.480	Bushing—Tap 5/8
6A	B647F 1/4	1	.542	Bushing for B641C800 Collet
6A	B647F 1/2	1	.590	Bushing for B641C800 Collet
6A	B647F 3/4	1	.697	Bushing for B641C800 Collet

Index No.	Part No.	Quan. Req.	Description
7	B647KS	1	Key for Collet
8	B647KT	1	Key for Index Disc
9	B820S	1	Swivel

Index No.	Part No.	Quan. Req.	Description
10	B942B	1	Base
11	B942T	4	T Slot Block
12	B947A	1	Collet Adapter



Right Hand Lift Cam

Index No.	Part No.	Description	A Size
13	B947C2	Flute 0 to 12 Tap	.275
13	B947C2	Flute 12 and over Tap	.355
13	B947C3	to 6 Flute 0 to 12 Tap	.281
13	B947C3	to 6 Flute 12 to 1/2 Tap	.375
13	B947C3	to 6 Flute 1/2 to 3/4 Tap	.468
13	B947C3	to 6 Flute 3/4 and over Tap	.562

Left Hand Lift Cam

Index No.	Part No.	Description	A Size
13	B947CL2	Flute 0 to 12 Tap	.275
13	B947CL2	Flute 12 and over Tap	.355
13	B947CL3	to 6 Flute 0 to 12 Tap	.281
13	B947CL3	to 6 Flute 12 to 1/2 Tap	.375
13	B947CL3	to 6 Flute 1/2 to 3/4 Tap	.468
13	B947CL3	to 6 Flute 3/4 and over Tap	.562



Index No.	Part No.	Quan. Req.	Description
14	B947D2	1	Index Disc (2 Flute)
14	B947D3	1	Index Disc (3 Flute)
14	B947D4	1	Index Disc (4 Flute)
14	B947D5	1	Index Disc (5 Flute)
14	B947D6	1	Index Disc (6 Flute)
15	B947F	1	Felt
16	B947H	1	Housing

Index No.	Part No.	Quan. Req.	Description
17	B947R	2	Cam Retainer Pin
18	B947S	1	Spindle
19	B947T	1	Thrust Collar
20	B947W	1	Draw Tube
21	B947Y	1	Coil Spring
22	6-32x3/4	4	S. T. Round Head Screw (N.P.)
23	1/4x1 SAE	1	Socket Set Screw
25	3/8x1 SAE	1	Hex Socket Cap Screw
26	1/4x1/2 USS	1	Hex Socket Cap Screw
27	1/2 USS	2	Hex Nut (H)
28	1/4 Std.	2	Lock Washer (L.B.)
29	RR-275	1	Spirolox—Internal

Figure 53A.

1. SHARPENING STANDARD TAPS UP TO 1 INCH DIAMETER

- A. Equipment and Accessories required (see Figure 53A)-B947 Tap Grinding Fixture; B641C S6 inch collet (STANDARD 5C-STANDARD EQUIPMENT), B647B Bushings to fit taps No 7 & 8, 9 & 10, 11 & 12, and sizes 4 inch, 1/6 inch, 1/8 inch, 1/16 inch, 1/32 inch, 1/64 inch, 1/128 inch, 1/256 inch, 1/512 inch, 1/1024 inch (STANDARD EQUIPMENT), B647B Bushing to fit taps No 0 to 6 (AVAILABLE ACCESSORY); B947C Six Lift Cams for R H Thread Taps (STANDARD EQUIPMENT) listed by flute range and tap rise; B947CL Six Lift Cams for L H. Thread Taps (AVAILABLE ACCESSORY); B947D Two, Three, and Four Flute Index Discs (STANDARD EQUIPMENT); B947DFive and Six Flute Index Discs (AVAILABLE ACCESSORY); B651C800 800 inch Collet for 1 inch taps (AVAILABLE ACCESSORY); B647F Bushings for B641C800 Collet, to fit 1X6 inch, 3YInch, and 1/4 inch size taps (AVAILABLE ACCESSORY)
- B. Mount the B947 Fixture on the left end of the grinder table as shown in Photo 53(INDEX NUMBERS ARE FROM FIGURE 53A)Mount a 6 inch straight wheel (80 GRIT) and wheel guard as shown.
- C. Swivel the tap grinder fixture base Swivel (No. 9), and thus the spindle, to the desired chamfer angle. Angles required for 2, 4, 6, and 8 thread chamfers are approximately 17 degrees, 9 degrees, 6 degrees, and 4 degrees respectively for standard chamfer taps
- D. Select the Index Disc for the tap size with the correct number of lifts on the Index Disc to correspond to the number of flutes on the tap Insert into the fixture as described in step E below
- E. Installation of the Index Disc (SEE THE INDEX NUMBERS IN FIGURE 22):
1. Unscrew the Collet Draw Tube and Handwheel from the Collet (NUMBERS 5, 20, and 4) and remove the Collet Adapter (No. 12), from the Spindle (No. 18).
 2. Remove the B947T Thrust Collar (No. 19) and B947Y Coil (No. 21) by releasing Socket Set Screw (No. 23).
 3. Pull out the Collet Adapter Assembly (No. 12) from the front end of the fixture.
 4. Remove the keyed Index Disc (No. 14) and install the one with the correct number of index lobes.
 5. If a different Lift Cam is needed, proceed to step F. If no different Cam is needed, omit step F and install the Collet Adapter Assembly again into the spindle in reverse order. Proceed to step G and following steps
- F. Selection and Installation of the Cam:
1. The Cam should be selected according to tap size. All Cams are stamped indicating the number of flutes and the tap size each will serve in addition to standard equipment cams for right-hand threaded taps, Cams are available for left-hand threaded taps
 2. Install the Cam into the Spindle Assembly
 - (a) Unlock the Spindle Housing by releasing the Hex Socket Cap Screw (No. 25).
 - (b) Pull the spindle forward from the Housing to expose the Cam.

- (c) The Cam is now free to be removed with one's fingers. Lift it up, as it is keyed to the Spindle.
- (d) Install the correct Lift Cam and push the Spindle back into the Housing position. When the Spindle Assembly is being installed, guide the Spindle through the rear end of the Housing by lifting slightly the rear end of the Spindle Assembly This procedure will aid in clearing the relief edge at the back of the Housing
- (e) Install the Collet Adapter Assembly in reverse order of step E
- (f) Lock the Spindle Housing temporarily and proceed to mount the tap

G Inserting the Tap into the Fixture:

1. Select the proper size Collet Bushing (B947B), dependent on the tap size, and insert it into the B641 9/16 inch Collet. For taps over 5/8 inch size a special B641C800 Collet and B647B Collet Bushings are used.
2. Insert the tap shank into the Collet Bushing Assembly up to the threads of the tap, if possible.
3. Lock the tap in the Collet by holding the Spindle Collet Adapter (No. 12) with the handle of a B628 7/8 inch Socket Wrench (standard equipment for Grinders) or similar round bar and tighten the Collet Draw Tube Handwheel at the back end of the Spindle.

H Set the Flute Clearance by Synchronizing the Lift Cam with the Tap Radial.

1. Turn the Collet Drawtube Handwheel in the opposite direction of the tap's cutting edge until the Spindle and Its Index Disc hit the positive stop of the Lift Cam.
2. Unlock the Spindle Housing by releasing the Hex Socket Cap Screw
3. Turn the entire Spindle Assembly in the opposite direction from tap's leading or cutting edge so that the heel of the radial clearance land on the grinding wheel side of the table is slightly above the fixture center horizontal plane for the right-hand taps and slightly below this horizontal plane for left-hand taps (THE SPINDLE IS ROTATED IN THE OPPOSITE DIRECTION TO THAT USED FOR SHARPENING).
4. Relock the Spindle Housing.

I. Sharpening the Tap While Producing the Radial Relief on the Teeth:

1. Set the wheelhead spindle at 90 degrees relative to the table.
2. Position the fixture and the table with the table handwheel so that the desired tap chamfer will be amply covered by the wheel side.
3. Feed the tap toward the wheel, using the grinder crossfeed, to a position just short of the wheel as shown in Photo 53.
4. Rotate the tap in its cutting direction with the handwheel and continue the crossfeed approach until grinding action begins. After initial contact with all flutes, move the table aside to check for correct relief generation.
5. Continue until the chamfer is produced and the tap cutting edges appear sharp. Care must be used to avoid any grinding action which will cause discoloration of the tap.

II. GRINDING TAPS OVER 1 INCH IN DIAMETER

A. Equipment:

The same equipment is required as is used for smaller taps, with the addition of the B641C .800 inch Collet, plus the following items: B647P Driver for the tap shank; A261G Spring Center or B922R Quick Release Spring Center Tailstock.

B. Set-up Procedure:

1. Insert the B641C .800 inch collet in the spindle and tighten.
2. Insert No. B647P Tap Driver in the B641C .800 inch collet and tighten.
3. Mount either a tailstock with a Spring Center or a Quick Release Spring Center Tailstock on the right-hand end of the table to receive the cutting end of the tap (see Photo 54).
4. Insert the tap. The tap shank is held in the driver while the center of the tap cutting end is held with the spring-center tailstock.
5. Proceed a, with taps under 1 inch diameter, described in steps I, B to I.

III. SALVAGING BROKEN TAPS

A. Insert the broken tap in the fixture in the same way as when sharpening a tap. Tighten as in step I-G-3.

B. Procedure for Grinding:

1. Remove the Lift Cam (see Step I-F-2 for access)
2. Bring the broken end of the tap into contact with the edge of the wheel (see photo 55) and centered with the wheel center.
3. While advancing the table, rotate the tap by the fixture handwheel in the opposite direction to that in which it cuts.
4. Grind the broken end of the tap off by rotating the tap against the wheel until a smooth, square end is obtained.
5. Replace the correct Lift Cam, select the proper Index Disc, and sharpen the tap as in steps I, B to I.

IV. GRINDING THE FLUTE CUTTING FACES OF THE TAP

Occasionally it is desirable to sharpen the teeth cutting faces of the tap from where cutting begins on the chamfer back to the rear of the cutting teeth. This is similar to grinding the teeth faces on form relieved cutters. This may be accomplished with the use of the B947 fixture and a toothrest set-up. However, for taps with spiral flutes, use of a fixture such as the B942 will be necessary to achieve ease of rotation against the fixed toothrest.

A. Initial Set-up:

1. Choose a straight wheel with an appropriate diameter and width forming a radius on its periphery to approximate that of the tap's flute gullet.
2. Position the tap fixture at the left end of the grinder table and set its base swivel to 0 degrees so that its housing and spindle will be parallel with the grinder table. Insert the tap as described in step I-G and then go back to step I-E following the process as described but remove the

fixture lift Cam (No. 13) and reassemble the fixture Spindle Assembly as described in I-F. This procedure will allow the fixture Draw Tube, Collet, and Collet Adapter (all of the moving inner spindle parts) to rotate freely together in a clockwise or counterclockwise manner. Lock Screw (No. 25) should be tight so that the outer spindle (No. 18) does not move. Loosen the thrust collar (No. 19) just enough so that the inner spindle assembly is easily rotated.

3. Raise the wheelhead so that the bottom of the wheel is just above one of the tap gullets and centered over it in its mounted horizontal position (e.g., see Photo 56). By moving the machine crossfeed and rotating the fixture movable spindle, place the wheel radius concentric with and tangent to the gullet radius. Take care not to allow the tooth face to strike the side of the straight wheel as this will destroy the radial rake on the face of the tooth.
 4. Since the toothrest position and its use in this set-up are similar to those used in grinding a form relieved cutter, consult Chapter 9, Parts I and III in this section for the general instructions relating to this sharpening process. Photo 56 shows the general position of the fixture and tap relative to the wheel. The toothrest, placed on the table, indexes on the back side of the tooth whose flute is being ground. If the tap is spiral, it is mounted in the B942 fixture and the toothrest is fastened on the wheel-head, as in Photo 39 of Chapter 9. Once the position of the tap gullet relative to the wheel has been established, set the micrometer toothrest to hold the flute against the stationary wheel. Do not move the crossfeed after this locating process has been completed as the proper rake angle for the tap has now been set.
- B. Grind the flutes in succession. Grinding is accomplished by moving the fixture and tap relative to the wheel with the table traverse handwheel, while at the same time holding the tap flute firmly against the toothrest blade with the fixture handwheel.
1. After a trial light cut on the first flute, inspect the tap to see if the grind is uniform along the length of the tap and to see that the original rake is being maintained. Make necessary corrections, and then select a flute gullet about 180 degrees opposite to the one just ground to see if the tap is running true.
 2. After the first light cut on all the flutes, move the tap away from the wheel and rotate the tap in its cutting direction (AWAY FROM THE TOOTHREST). Next, move the micrometer toothrest a slight amount in order to advance the flute face toward the wheel. Now move the tap flute back against the toothrest blade. The index feed for the flutes per pass should be no more than .001 inch on the toothrest micrometer. Heavy cuts can set up a burr between the cutting teeth and reduce the strength of the cutting edges.
- C. Spiral Taps:
1. As stated previously, spiral tap faces must be ground with the use of a B942 workhead or similar workhead with anti-friction bearings. Large taps will require the use of a special long toothrest guide (SUCH AS THE B670RB) as well as the use of the B647B Driver and a left side tailstock.
 2. The grinding procedure is the same as described for hobs in Chapter 9 but modified by steps A and B above.

Instruction Manual

CHAPTER 13

Cylindrical Grinding and Internal Grinding

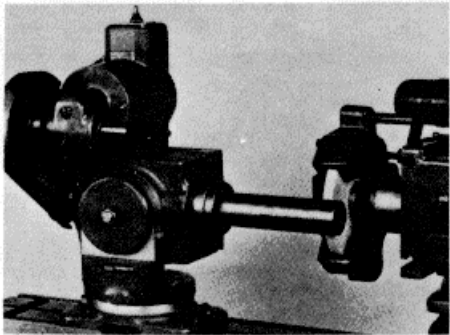


PHOTO 57

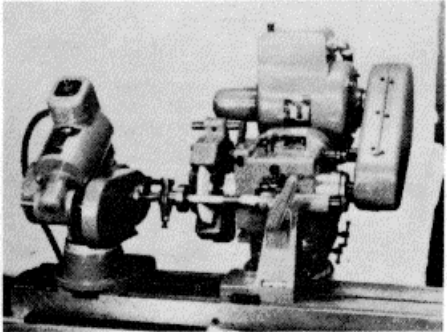


PHOTO 58

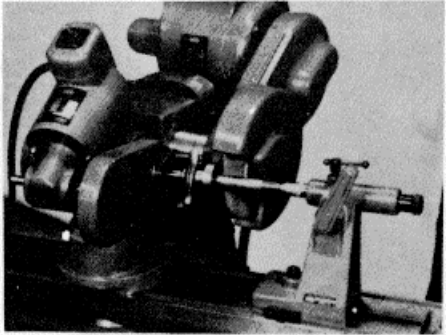


PHOTO 59

On Universal Grinders, cylindrical grinding is accomplished either by using the standard spindle with the machine or by obtaining a high-speed spindle which has the capability of mounting both Internal Diameter (I.D.) wheels and the larger wheels for Outside Diameter (O.D.) work. Machines that have been supplied with only a heavy-duty spindle will require an additional spindle capable of achieving Internal Grinding R.P.M. See Section Six, by Part IV, page 103, for a complete listing of standard and available spindles for I.D. and O.D. cylindrical grinding. These belt-driven spindles in the grinder wheelhead are used

in conjunction with a motorized workhead such as the B943, B2043, B6043, B9043 or B10043. In Photo 57, the workhead spindle is belt-driven. As shown in Photo 58, the belt-drive is used to turn the Drive Plate with the Dead Center Assembly seated in the taper of the workhead spindle; the spindle is locked relative to the workhead housing. If adequate space does not seem to be available between the workhead spindle face and the wheel, move the workhead further to the left or use the two wheelhead swivels (ABOVE AND BELOW THE DOVETAIL SLIDE) and the dovetail slide to off-set the wheelhead from the column farther to the right, thus moving of the usual wheel end of the spindle also to the right. Under extreme conditions, it may be desirable to drive the spindle from the left side of the motor shaft extension allowing the wheel to be placed on the right end of the spindle. If desired, the spindle may be removed from the workhead and reversed with the usual pulley end at the left side of the head and driven from this side. On machine models which have spindle wheel collets (arbors) on both ends, the belt-drive may remain on the right side of the spindle even when certain wheels are mounted there (Photo 59). Wheel guards can be attached to the right side of the spindle housing.

Instruction Manual

The cylindrical grinding set-up makes possible the grinding of reamers, lathe centers, mandrels, straight or tapered tool shanks, gauges, and many facing operations performed on cutters. The work may be held in a universal chuck mounted in the workhead spindle, in a collet with collet fixture, or in various other adapter sleeves if no cutter for support is needed on the unheld end of the work. Work ground between centers will use a right-hand tailstock and a dead center in the workhead at the left of the machine table. The B943 Motorized Workhead can be mounted on either the BA985 or BA986 Radial Grinding Fixture for special I.D. or O.D. work

I. OUTSIDE DIAMETER CYLINDRICAL GRINDING

EXAMPLE: Grinding a special shaft and flange component. (See Photos 58 and 59)

- A. If the machine has a tilting wheelhead, place it in the horizontal or 0 degree tilt position. When mounting a straight wheel, regardless of machine model, place the axis of the wheel spindle parallel with the table travel. Lock all swivels and slides tightly.
- B. Adjust the height of the wheel (SPINDLE) center to the height of the centerline of the tailstocks and tighten the column lock on all machines with a 4-inch diameter column. Place the correct pulleys, drive belts, and guards on the motor shaft and spindle. Install the appropriate wheel on the wheel collet or the wheel arbor which has been locked onto the respective spindle **(SEE SECTION IV, PART III, PAGES 13, 15, 16, 17, FOR DETAILS ON MOUNTING WHEELS.)** True and dress the wheel with the machine diamond dresser. Truing the wheel means removing material so that the surface runs absolutely true relative to the spindle. This procedure must be repeated every time a wheel is mounted on the spindle arbor or when a collet mounted wheel is attached to the spindle. Dressing the wheel cleans and restores the sharpness of the wheel face.
- C. Place the motorized workhead to the left side of the table and lock it to the table with the T-slot bolts in a position which will allow adequate room for the work holding device in the workhead spindle and for the work length to the left of the wheel.
- D. Place the Driver Plate and Dead Center Assembly in the taper lock of the workhead. Tighten the workhead spindle lock screws. Loosen the motor bracket screws. Remove the wheel guard from the left side of the workhead, remove the belt and remove the pulley from the left end of the motor shaft. Transfer the pulley and belt to the right side of the motor shaft placing the belt on the Driver Assembly pulley which will give the desired work R P M. **(SEE GRINDING HINTS, PART III.)** Slide the motor bracket forward and down and lock the hex head screws. Leave some slack in the belt. Replace the wheel guard. The workhead is now ready to turn the work or arbor about the dead center by means of the Drive Pin.
- E. Attach the drive dog to the work or work holding arbor and mount the work between the dead center and the right-hand tailstock which has to be positioned so as to allow some spring tension adjustment between the tailstock and the work. Always check the need for setting machine longitudinal stops to avoid the wheel running into the machine or into work not to be ground.
- F. Check to see that the table taper indicator at the left end of table is set for 0 degrees or taper per foot if no angle is desired on the work to be ground.

Instruction Manual

For extreme accuracy, it will be necessary to install a test arbor in the workhead or between centers to check for alignment with the table travel. If enough material is to be removed, the work may be gauged as ground and the table taper adjusted.

- G. If very heavy work is placed on the machine, it may be desirable to tighten the right-hand tailstock Lock Screw on top of the unit. Clean and examine the work centers for scoring. They must be reground if scored. Apply center oil to the work centers before placing the work or arbor into position.
- H. Start the motorized workhead in the "forward" direction and the wheel rotating in the "forward" direction; this will give opposite rotation at the point of contact. Approach the work slowly until the first contact is made. Set the crossfeed dial at 0 and begin to traverse the table with an even motion to the right and left -far enough so that only about one third of the wheel travels off the work. Traveling completely off the work produces undersized work ends; not traveling far enough off the work produces oversized work ends. The wheel may have to be slightly recess dressed on the side back from the periphery in order to avoid touching critical shoulders when the work diameter changes. No more than .0005 to .001 inch of crossfeed should be taken per traverse of the work. The amount removed per traverse by cylindrical grinding will be equal to twice the infeed taken on the crossfeed of the grinder.
- I. If the machine is equipped with coolant, use an adequate flow of this over the work at all times because it will provide more accuracy and will usually improve the final finish on the work. Excessively dirty coolant will produce a scratchy, poor finish.
- J. Wheel and work rotation speed and work traverse speed:
1. The usual R.P.M. for straight wheels yields between 5500 and 6500 surface feet per minute. This S.F.P.M. is partly governed by the stated maximum wheel R.P.M. While WORK speeds from 40 to 50 S.F.P.M. cover the majority of situations, the extreme limits are about 30 for hardened steel and 100 for finishing cuts on soft material. Work traverse rate per revolution of the work is usually in a ratio of about 2/3 to 3/4 of the wheel width to one revolution of the work.
 2. At each end of the table traverse, the table should "dwell" or stop momentarily. This action prevents the jar that results if the table is instantly reversed. It also aids in holding size as the front edge of the wheel does the heaviest part of grinding and the after-edge cleans up the cut, reducing it to size. Consult the instructions on hydraulic controls, Section Four, Part III, Page 11, if the machine has a power-driven table.
- K. Plunge Grinding:
1. In this process, the crossfeed is usually the only control that is used, and the work is smaller in length than the wheel face width.
 2. If the plunge is into work which is longer in length than the face of the wheel (OR A PROFILE DRESSED INTO THE FACE OF THE WHEEL), then the work must remain in the same longitudinal position.
 3. When possible in plunge grinding, oscillate the wheel slightly to prevent lines in the work.

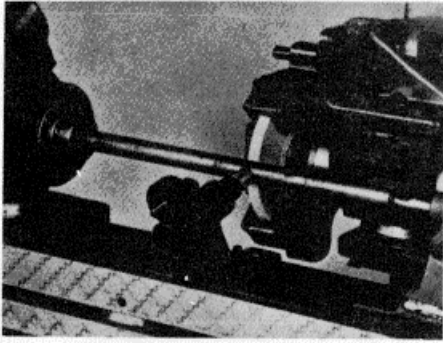
Instruction Manual

PHOTO 60

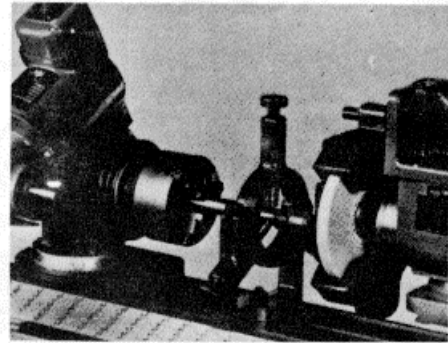


PHOTO 61

L. Special Steady Rests

1. To aid in the support of the work against the grinding wheel pressure which forces the work down and away from the wheel, one or more steady rests should be employed when grinding long, relatively thin pieces. Care must be taken not to force the work into the wheel, as such forcing will cause the work to be ground to a smaller size in the area of the steady rest than at other places.
2. **Special steady rests, such as the BA969 Follow Rest or BA938 Steady Rest (Photos 60 and 61), are available for K. O. Lee Grinders.**

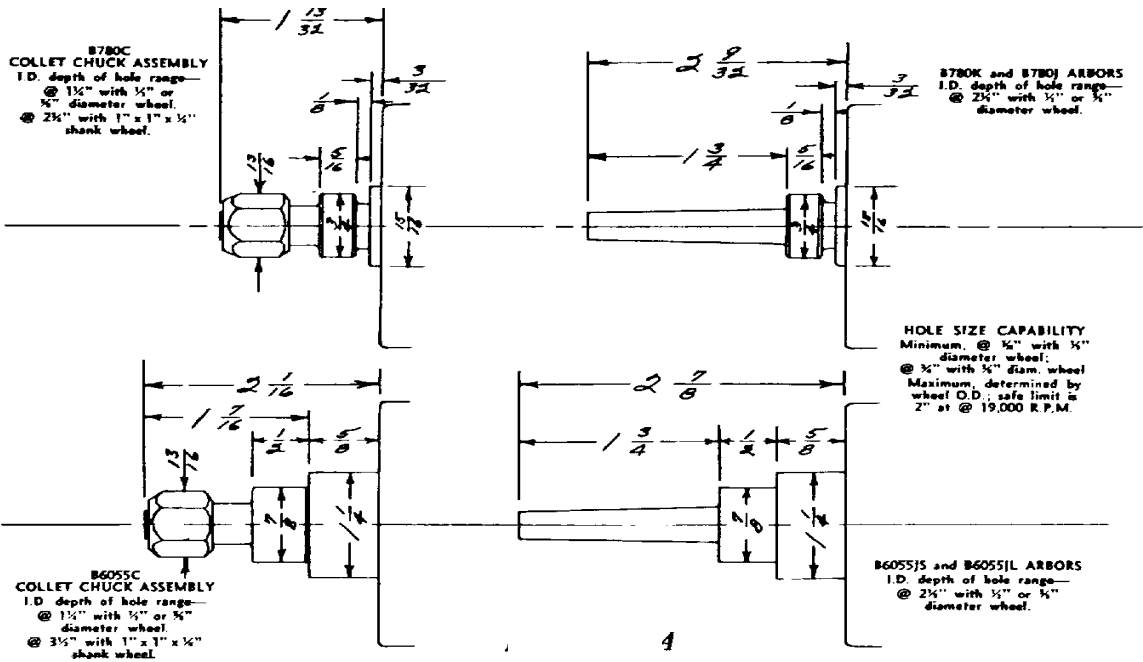
M. If grinding in recessed areas with the wheel on the left end of the spindle proves difficult due to wheelhead swivel interference, mount the wheel on the right end of the spindle as shown in Photo 59 and explained in I-C above.

II. INTERNAL CYLINDRICAL GRINDING

This-type of cylindrical grinding is used to finish holes in cutters, bushings, gauges, and other machine parts. Holes may be straight, tapered, or formed relative to the axis of the work. With the exception of honing, internal grinding is the most accurate method of furnishing holes to size. The universal tool and cutter type of machine provides internal grinding capacities that will handle most requirements for the average shop or toolroom. The general method of producing the grinding action is similar to that of O.D. cylindrical operations

On many K.O. Lee grinders, the standard spindle on the machine is capable of holding I.D. wheel-holding arbors and can achieve the necessary high R.P.M. to obtain the correct surface feet per minute. The machine wheel speed plate will usually indicate whether the machine's spindle is of this type. If the machine has only a heavy-duty spindle, an additional spindle (QUILL ASSEMBLY) must be obtained to accomplish I.D. work. Consult Section Four, Part III, Pages 13, 17 for Instruction on the attachment of internal grinding wheel-holding arbors onto the spindle. The functioning of the motorized workhead is described in Section Four, Part III, Page 18, and also in this chapter, Part I. It will often be used with the three-jaw universal chuck (LOCKED INTO THE SPINDLE TAPER, SEE PHOTO 62), which is capable of holding most work pieces. Small bushings can also be held in the workhead with the aid of a collet fixture and spring collet. Consult Figure 62A of this chapter for dimensions of I.D. arbors and approximate I.D. grinding hole size and depth.

Instruction Manual



EXAMPLE: Grinding a hole gauge (see Photo 62).

- A. Consult the wheelhead wheel-pulley chart and select the proper pulley for the motor shaft and the wheel spindle. These will depend on the R.P.M. desired for the spindle which will depend on the wheel size chosen for the job. The size of the wheel relative to the hole to be ground is not critical, but too small a wheel will affect accuracy due to wear and other factors. If grinding a 1/2 inch hole, use approximately a 3/4 inch wide wheel; if working on a 2 inch hole, use approximately a 3/4 inch wide wheel. Wheel speeds will be between 5500 and 6500 S.F.P.M. After installation of the pulleys and belt, replace the belt guard.

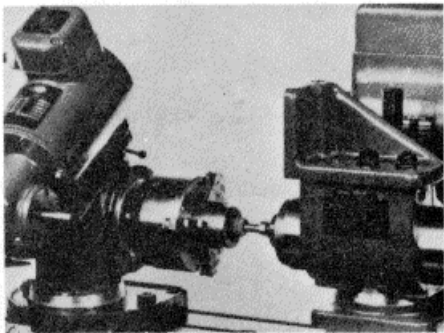


PHOTO 62

- B. Install the correct internal grinding motor arbor in the left end of the spindle, locking it securely into its internal taper or against the outside face of the spindle, depending on the spindle construction. If the arbor chosen is of the collet type, choose the wheel desired, insert the wheel shank well into the collet, and tighten. If the arbor has an internal thread for mounted wheels with threaded shank, turn the wheel shank into the end of the arbor. Test run the spindle. Check for excessive vibration. There will be a high-pitched hum which is natural.
- C. Mount the motorized workhead on the table at the left end. Attach the

Instruction Manual

work-mounting device into the workhead spindle. Mount the work and check its runout with an indicator. Very thin bushings may have to be held with the aid of a special bushing chuck or by end pressure to avoid distortion.

- D. Loosen the handle screws on the right side of the wheelhead dovetail slide and move the wheelhead forward enough so that there will be adequate crossfeed capability while aligning the wheel with the work hole. Tighten the dovetail handle screws and make sure all other wheelhead swivels are tight.
- E. Using the machine height gauge, put the centerline of the wheel spindle at the same height above the table as the centerline of the workhead spindle. The wheelhead spindle axis is also placed parallel to the table travel by putting the swivel(s) at 0. It is also important to align the centerline of the workhead spindle with the direction of the table travel. Put the workhead fixture base at 0 degrees and make adjustments with the table taper adjusting screws at the right end of the table. This may be done during grinding, starting with a table adjustment reading of 0, but it is more accurate to use an indicator and a test arbor in the workhead spindle before attaching the workholding device and the work.
- F. Before starting the wheel spindle or the workhead, traverse the table enough to the right to set a depth stop on the table. The wheel should not protrude from the hole more than 1/4 to 1/2 of its length. When using a power table travel machine, set a stop for travels in both directions.
- G. Start the machine wheel spindle and true and dress the wheel. If the wheel is dressed on the side facing the operator, then this same side should be used to grind the work piece. Start the workhead and operate it in a direction opposite to that of the wheel at the point of grind. Move the wheel into the work hole, advance the crossfeed until contact, turn on coolant, and use the same grinding practices as explained in I and II of this chapter.

III. GRINDING RULES APPLICABLE TO CYLINDRICAL GRINDING

- A. A loaded wheel will mar the surface of the work rather than finish it. With a slow work speed, a light cut, and a hard wheel, the wheel will dull easily and become glazed. Increasing the work speed tends to make the grinding wheel act softer, and vice versa. A glazed wheel is not sharp and eventually will rub, burn, and destroy the work.
- B. A slow work speed combined with a soft wheel is better than a fast work speed and a hard wheel because there is less tendency to heat and distort the work. However, neither extreme is desirable.
- C. When grinding hard materials, use a soft wheel or increase the work speed so that the dulled grains will wear off evenly.
- D. Work of a large diameter calls for a softer wheel and slower work speed than does work of a small diameter, and vice versa.
- E. Cracks, checks, and burns caused by excessive heat generation may be due to too hard a wheel, too heavy infeed, too slow work speed, insufficient grinding fluid, a glazed or dulled wheel, or an improperly dressed wheel. Keep the wheel dressed to maintain a free cutting action. Use an adequate coolant stream at the point of contact.
- F. The table traverse should be constant and not stopped during the process of

Instruction Manual

a cut across the work. Steady movement is essential. When finish grinding, reduce the traverse speed. Experience will tell the correct traverse for the size and type of work.

- G. The revolution of the work should not be stopped until the wheel has been backed away from the work.
- H. After the first cut is taken, the work should be measured for straightness and machine setting. If the work is found to be larger at one end than at the other, the table should be swiveled sufficiently away from the wheel at the small end to correct the error.
- I. All of the human senses may be utilized to advantage by the experienced operator:
 - 1. Watch the sparks. Much can be told about the progress of the work by the sparks. When the work is turning slowly, any out-of-roundness will manifest itself by intermittent sparking. If the work is irregular in diameter at different points in its length, the condition will be shown by changes in the amount of sparking. If the sparking has been regular and suddenly becomes irregular, the fault may be that the work is over heating, the centers are dry or loose, steady rests are out of adjustment, or the wheel may have dirty or glazed spots
 - 2. Listen. Learn to use your ears for the informative sounds given off by the wheel. Much can be determined by these sounds. During the truing and dressing of a wheel, the sound will indicate if it is out-of-round. A clicking sound might indicate a crack in the wheel. The note given off by a running wheel changes as the wheel breaks down. A wheel which is acting too hard gives off a note of high pitch, while one that is acting too soft will chatter and break down frequently. When the wheel approaches the work, it gives off a hissing sound which changes with its relative proximity to the work. By close observation of the various sounds, the operator may develop his judgment to a point where his efficiency is greatly increased.
 - 3. Feel Use the sense of touch. An out-of-balance wheel will cause vibration. The operator's sense of touch will discover this. Work finish may be judged by touching the revolving work. Grit in the coolant may be detected by feeling.

Instruction Manual**CHAPTER 14****Special Operations and
Miscellaneous Tool Grinder Set-Ups****I. CYLINDRICAL AND FACE GRINDING OF CARBIDE MILLING CUTTERS****A. Equipment Required:**

1. Motorized Workhead (see Section Six, Part III, Pages 99 and 100)
2. Grinding Wheels'
 - (a) Roughing wheel for circle grinding. We recommend a 6 inch diameter silicon carbide straight or recessed wheel, 1/2 inch wide, with a 1 1/4 Inch bore hole (S755CL, B6062A QUILLS), or a 5/8 inch bore hole (B955A, B6055A QUILLS).
 - (b) Diamond wheel for finish grinding. Grinding requirements will determine the type of grinding wheel needed (Flaring Cup, Straight or Saucer Shape). We recommend a resinoid bond diamond wheel, 150 to 180 grit, 100 concentration.
3. A double end diamond hand hone with 400 grit on one end, 500 grit on the other, vitrified bond, 100 concentration, 1/32 inch diamond depth.
4. A diamond wheel dressing stick.
5. A 10 to 20 power magnifying glass
6. Use of the machine mounted light

B. General Instructions:

1. Cylindrical Grinding Cylindrical (or "circle") grinding is performed after new teeth have been brazed to the cutter body or when adjustable blades have been "set out." This operation assures that the outside diameter of the cutter will be concentric with the milling spindle and that there are no "high teeth" on the periphery of the cutter. Cylindrical grinding operations are performed with the cutter mounted in the motorized workhead in the position as shown in Figure 57, Chapter 13. Use a silicon carbide grinding wheel, such as the RV6NH100, for rough grinding the periphery. Feed the cutter against the wheel at a moderate rate. Feeding the cutter at too slow a feed rate will cause the grinding wheel to glaze, overheating the cutter, causing the carbide to crack.
2. After the cylindrical grinding operation is completed, check to see that there is sufficient clearance behind the carbide teeth to prevent the diamond wheel from grinding into the steel portion of the cutter. On inserted tooth cutters, the steel portion of the tooth should be relieved with an aluminum oxide grinding wheel. On brazed tooth cutters, the carbide teeth should project .040 inch to .060 inch beyond the outside diameter of the cutter body. Ample grinding wheel clearance should also be provided for grinding the face of the carbide tooth. When the carbide clearance land has been ground to the extent that the diamond wheel is grinding the cutter body, the teeth should be "set out" or replaced.
3. Mount the diamond wheel on a wheel collet in the manner described in

Instruction Manual

the general instructions, Section Four, Part 111, Page 13 to 17. Mount the grinding wheel and collet assembly on the spindle of the machine. Check diamond cup wheels with a dial indicator to determine if there is any face "run-out." Check straight diamond wheels with a dial indicator to determine if there is any peripheral "run-out." Do not correct for run-out by truing the wheel. Face run-out on cup wheels can be corrected by scraping the back of the hub. Peripheral run-out on straight wheels can be corrected by shifting the wheel on the collet. Run-out should be reduced to .0005 inch before truing the wheel. Check the grinding wheel and collet assembly for run-out periodically during use. After the wheel has been mounted properly and trued, it should not be removed from the collet until it is replaced.

4. Use of a mist coolant, oil based or other, is desirable during the finish grinding operations. A cutting fluid adds to wheel life, improves work finish, and prevents over-heating and cracking of carbide.
5. Use a magnifying glass to check carbide for cracks before, during, and after the grinding operation. If cracks are long, it may be more economical to replace the carbide blade rather than attempt to grind away the crack.
6. When a diamond wheel is used, be certain that the spindle speed is correct for the wheel being used. Keep stock removal and rate of table travel low. Stock removal should not exceed .0005 inch to .001 inch per pass for general purpose work or .00025 inch per pass where an exceptionally good finish is required. Table traverse should be approximately 50 inches per minute for rough grinding and between 10 to 20 inches per minute for finish grinding.
7. After grinding is complete, recheck the teeth for cracks with a magnifying glass. If any teeth are cracked, they should be replaced. Check to see that the proper clearance has been ground and that there is no interference on the cutter body. This step is especially important when grinding small-diameter milling cutters.
8. The cutting edges can be honed lightly with a diamond hand hone to break the sharp edge slightly. This procedure will help to improve cutter life.

Grinding a Carbide-Tipped Face Mill. (BEFORE ATTEMPTING TO GRIND A CARBIDE FACE MILL, READ THE GENERAL INSTRUCTIONS ABOVE.)

1. Cylindrically grind the periphery and chamfer with the silicon carbide grinding wheel. **NOTE:** This step applies only to cutters with newly brazed teeth and to inserted tooth cutters that have been set out or that have been fitted with new teeth.
2. Remove any recess brazing material from behind the carbide teeth that project from the cutter body. Leave the cutter in the workhead and the workhead axis parallel to the grinding table. Remove the motor and belt. Position a micrometer toothrest support behind the cutter (mounted on the table or workhead) with a round-top blade resting against the back of the top tooth. Set the wheel spindle axis perpendicular to the grinder table and mount a diamond cup wheel.
3. Create a set-up similar to grinding the faces of a form relieved cutter, as shown in Photo 63. Put the workhead (cutter) axis in the same vertical plane represented by cup wheel face. Place the peripheral cutting face of the tooth on this vertical centerline and make crossfeed adjustments (ROLL-

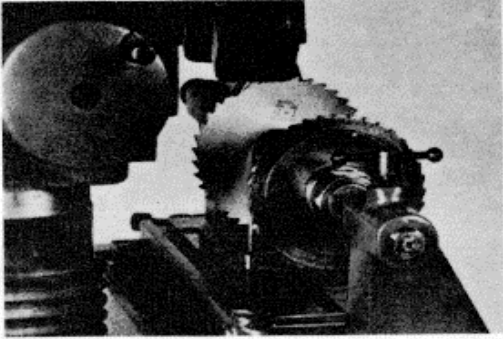


PHOTO 63

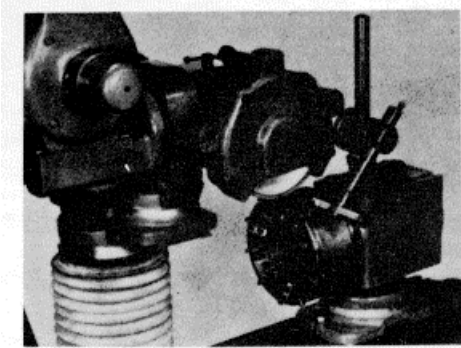


PHOTO 64

ING THE CUTTER) to allow for the cutter's radial rake. Once this alignment is accomplished, the crossfeed is not moved during the facing operation.

- 4. Initially set both swivels of the workhead at 0 degrees; then place the face of the tooth parallel to the face of the grinding wheel by swiveling the workhead in the horizontal plane to the desired axial rake.
- 5. Grind the face of the tooth in the same manner as described for form relieved cutters in Chapter 9, using the micrometer toothrest to rotate the cutter into the wheel. Index the workhead to the next tooth. **NOTE:** Due to possible variation in thickness of carbide blades (ON INSERTED TOOTH CUTTERS) each tooth face should be ground individually. Adjust the micrometer toothrest support to permit the grinding wheel to clear the face of the next tooth. Position the grinding wheel in front of the tooth and readjust the toothrest until the grinding wheel "touches up" on the face of the tooth. Grind this tooth to the same micrometer setting as that of the preceding tooth. **NOTE:** After this operation is complete, the carbide teeth will be of equal thickness. This makes it possible to index the cutter from the back of the teeth (if desired) during grinding of the clearance lands.
- 6. After the face of each tooth has been ground, set up the machine to grind primary and secondary clearance (if necessary) back of the periphery, corner, and cutting face of the cutter. Primary clearance should be about 1/32 inch wide. Follow instructions in Chapter 8, Page 43, for grinding face mills. If the cutter clearance is not known consult the general Clearance Angle Chart, Page 107, and the Tables II and VI for periphery, corner (chamfer), and face given on pages 105 and 108.
- 7. Remove the cutter from the workhead and check the face, corner, and periphery for concentricity. Run-out should be limited to .0005 inch for cutters up to 6 inches in diameter and .001 inch for cutters 6 inches to 12 inches in diameter. Be certain that no portion of the cutter body projects beyond the cutting edge.

II. MISCELLANEOUS CUTTERS

A. Metal Cutting Saws:

- 1. Mount the saw in the vertical plane on an arbor placed between centers,

Instruction Manual

as shown in Photo 64. Note that an index disc is used in conjunction with a plain toothrest in order to facilitate accurate and 'easy indexing of the teeth.

2. If the saw is badly worn, if a tooth is broken off, or if it is in need of gumming, grinding the face of each tooth and the gullet between that tooth and back of the preceding one is required. In many cases this will prevent the necessity of grinding a heavy primary relief. Dress a straight wheel, as shown, to a 60 degree angle (OR WHATEVER ANGLE EXISTS BETWEEN A TOOTH FACE AND THE BACK OF THE PRECEDING TOOTH). Turn the wheelhead axis 90 degrees to the table travel. Adjust the saw gullet relative to the wheel using the machine crossfeed and elevation handwheels. Once the cutter is positioned relative to the wheel, set the plain toothrest on the table and adjust the toothrest's micrometer until its blade is firmly against a convenient index disc notch. Grind the face and tooth back by table traverse action while periodically lowering the wheelhead. **NOTE:** Do not move the machine crossfeed once the cutter has been positioned relative to the 'V' dressed wheel.
3. When the gumming process has been completed, remove the wheel and place a cup wheel or straight wheel on the spindle. Use the toothrest and the index disc or the saw teeth themselves for indexing in order to create a primary land on the periphery of the saw. Be careful not to burn the teeth ends (a Saucer Wheel may be helpful in this regard). Follow the general procedures described in Chapter 5 for straight tooth side milling cutters for grinding the primary and secondary clearance lands, as applied to Photo 65. Saws used for gang slotting should be grouped together on a straight arbor and gummed or sharpened as described above.

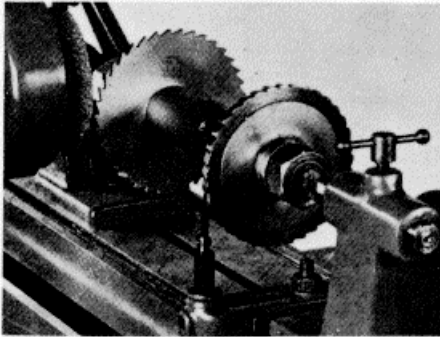


PHOTO 65

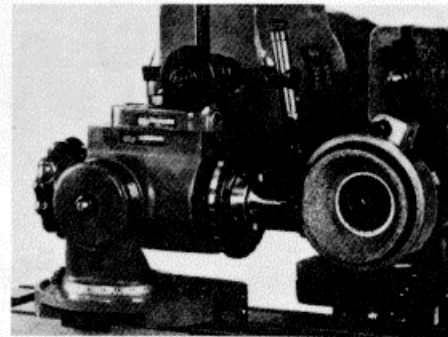


PHOTO 66

B. T-Slot, Woodruff Keyseat, and Keyway Cutters:

1. T-slot cutters are of the stagger tooth type with alternate left and right helix. On their periphery, these cutters are sharpened in the same manner as a stagger tooth cutter except that the shank is held in a universal workhead such as the B942. The sides of the teeth are sharpened in the same manner as the face of an end mill or the sides of a side milling cutter. A saucer wheel may be necessary to reach the side teeth clearance lands between the cutter and the end of the workhead spindle. Consult Chapter 6 for details of the sharpening process.

Instruction Manual

- 2. Photo 66 shows the typical set-up for sharpening the periphery of a Woodruff Keyseat cutter. These cutters are sharpened only on the periphery as the sides are relieved by a slightly concave surface. The cutter shank is most easily held by a collet in a universal workhead. Grinding procedure is the same as that given for straight tooth side milling cutters in Chapter 5. In general, keyway cutters are of specific width, as are keyseat cutters, and sharpened only on the periphery.

C. Single Point Tools-USE OF B945 TILTING TABLE FIXTURE:

Although tools with carbide replaceable-tips are widely used nowadays, there is often need for a fixture which can be used in grinding precise relief angles on cemented carbide and high speed point tools. The Tilting Table Attachment (Photo 67) makes it possible to address a silicon carbide or diamond recessed wheel at a relief angle on the end or side of a tool up to 20 degrees. The protractor can be used to guide the tool toward the wheel while maintaining a set end cutting edge angle or side cutting edge angle. The protractor also has a diamond screw nib for dressing the wheel. Figure 67A gives the nomenclature for a typical single point tool.

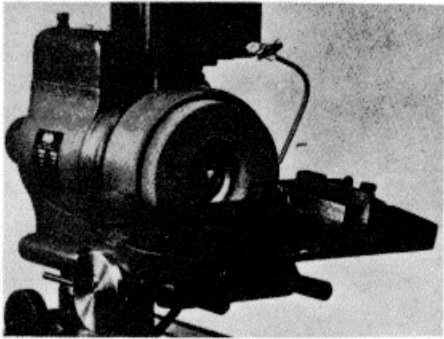


PHOTO 67

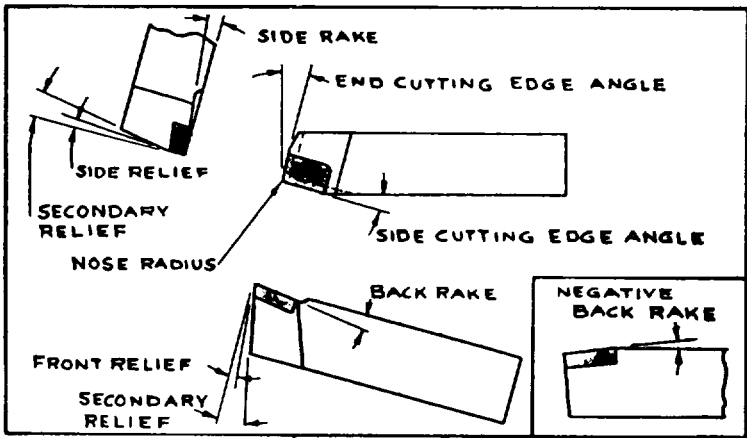


Figure 67A-Tool Angle Nomenclature

- 1. General Procedure for Set-up:
 - (a) Loosen the handle screw underneath the right side of the table; this allows the table to be tilted. Move the eccentric mounted wheel at the left of the table to the desired relief angle. Lock the handle screw again. Now re-adjust the whole tilting table slide mechanism toward the wheel until it is about 1/16 inch from the wheel. Lock the set screws on the sliding bracket. If several angles will be used

Instruction Manual

during the set-up, allow enough room between the table and the wheel so that the table can be swiveled to greater or lesser angles without disturbing the slide bracket.

- (b) Start the wheel (RUNNING DOWN AT THE POINT OF CONTACT) and use the diamond dresser to true and dress the wheel to either an open condition (ROUGHING) or smooth condition (FINISHING). Take no more than .001 inch off the wheel per pass, but vary the speed at which the protractor is moved across the wheel.
2. Grinding Procedure: If the tool has been chipped or broken, or if it is very dull (OVER .030 INCH WEAR BELOW THE CUTTING EDGE), it should be rough ground prior to finish grinding.
 - (a) If the tool is chipped or broken, rough grind the steel shank below the carbide on an aluminum oxide wheel located elsewhere, using an off-hand method. Grind on the corner of the wheel while approximating the original relief angle. Remove the steel behind the carbide on top of the tool, if necessary, in the same manner.
 - (b) With the silicon carbide wheel dressed for rough grinding, grind a relief for the end and side. The wheel provided is 100 grit which is suitable for both roughing and finishing of tools for many operations. Under some conditions, coarser grit is desirable. If only a narrow primary land is desired, grind the secondary angle first with the roughing wheel. Keep the wheel rough dressed during this operation by using the abrasive wheel dresser supplied with the machine. For this operation, use only the table as a steady rest while keeping the tool in constant motion by (i) moving it back and forth across the wheel face, (ii) rocking it, and (iii) tipping it up and down slightly. Grind the wheel running onto the tool at all times. Dry grind during this process, always allowing the tool to cool naturally. Never quench carbide in water or oil. When the worn or broken portions have been ground away, redress the wheel for the final roughing of the secondary or primary relief angle. Hold the tool with light pressure against the wheel, moving it constantly.
 - (c) The sequence for both rough and finish grinding is as follows: Grind the top face of the carbide first. Next, grind the side relief, followed by the end relief. Then grind a chip breaker back of the cutting edge if the situation calls for this. Since chip breakers require a separate tool holding device, wheel, and procedure, this subject is left for more detailed handbooks. **NOTE:** Tools may have either positive or negative back rake, or none at all. Before the top face is ground, check the side and back rake angles and set the table and protractor accordingly so that these angles will be generated when the tool is turned on its side and its face held against the wheel.
 - (d) Finish grinding is accomplished by smooth dressing the standard silicon carbide wheel or by changing the wheel to a diamond wheel of approximately 220 grit. The latter type of wheel is especially desirable for finishing tools to be used on cast iron or nonferrous metals. Keep diamond wheel clean with the use of a fine grain silicon carbide dressing stick. If coolant is used, always keep a generous supply of coolant running on a diamond wheel if possible, as this will keep the wheel clean longer and reduce the chance of cracking the carbide. Set the tilting table at a primary relief if a

Instruction Manual

secondary relief was ground first. The width of the primary land need not exceed X6 inch. After the primary relief has been ground on the side and front end of the cutter, grind the necessary nose radius between the two lands. Hold the tool lightly and rotate it in a full arc from the side to the front while against the wheel face.

III. SALVAGING TOOLS

A. Salvaging End Mills -Using A Standard Cut-Off Wheel

1. Mount the cutter in a standard universal workhead with the mill axis parallel to the table travel. Lock the workhead spindle. Mount a standard 6 x 1/16 or 1-32 inch cut-off wheel to the grinder spindle. Mount a wheel guard. A wheel, such as the PR6AH70 (S.F.P.M @ 6,000), can be used for this operation. Wheel bond may be shellac, rubber, or resin. Insure that there is sufficient machine crossfeed travel to pass the wheel through the mill. The swivel can be used to position the cutter axis closer to the wheel spindle. Position the wheel periphery just back of the broken tooth and center the wheel center height with that of the workhead. Start the wheel motor in the "forward" direction. Use the machine crossfeed to move the wheel through the mill as rapidly as the wheel can cut. Moving the wheel through the cutter too slowly will burn the cutter by glazing the wheel. **NOTE:** The following alternate methods may be used.
 - (a) Set the wheel spindle at 90 degrees to the table using the transmission as a means of power to pass the wheel through the end mill. In the latter case, the workhead spindle is also rotated 90 degrees relative to the table.
 - (b) Mount larger cutters or cutters which tend to heat during static cut-off in a motorized workhead at the left end of the table. Mount the wheel in the usually cylindrical grinding position. Rotate the cutter in the opposite direction to that of the wheel at the point of contact and cut rapidly through the mill.
2. If the peripheral flutes need gumming, perform this operation at this point using the method described in B-2 below.
3. Grind the teeth end clearances by the following general outline.
 - (a) Although it is usually not necessary, some end mill usage may require the center portion of the end being relieved. In this case, mount a small straight wheel or cup wheel and plunge grind the center portion of the mill to desired relief depth and diameter.
 - (b) Set the end of the mill in relation to a cup or saucer wheel as shown in Photo 68. Initially tilt the workhead up to place the desired primary clearance land on the cutter. Note that the toothrest is mounted on the workhead with the upright shaft extended through the bottom of the toothrest base. The spring-blade micrometer is used for direct indexing on the teeth faces. The outer edge of the cup wheel should have a small radius dressed on it. The wheel elevation must be located so that the O.D. of the wheel will create the desired form for the end face of the tooth following the one on which the clearance is being ground. Set a table stop to achieve the same form depth on all teeth. The wheel O.D. Should extend to the mill center, if no center relief is ground. After com-

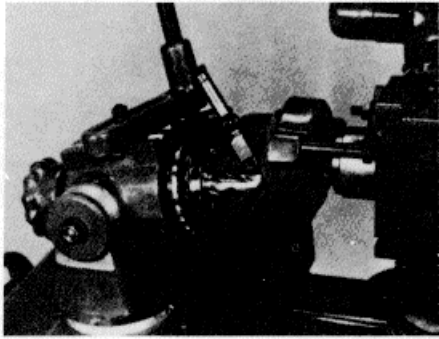
Instruction Manual

PHOTO 68

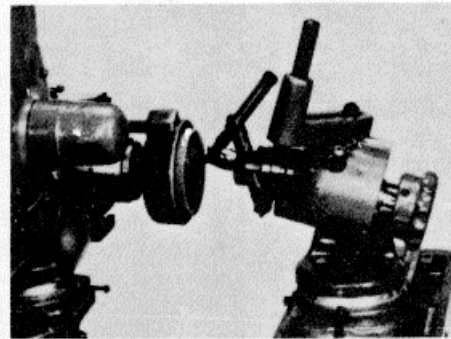


PHOTO 68A

pleting the first operation, tilt the workhead up further for the secondary or chip clearance angle. The wheelhead elevation must again be adjusted so that the O.D. of the wheel will blend in with tooth face and helix of the cutter. Grind the secondary clearance until the desired primary land width is achieved. In the photo, since the wheel is always cutting on the left side of the mill and (FACING FROM THE FRONT OF THE MACHINE), the workhead has been swiveled approximately 92 degrees counterclockwise during both primary and secondary angle settings to give end relief to the end cutting edges.

- (c) The grinding process consists of a gradual surface grinding operation in the vertical plane using the table action to move the mill end approximately one half its width across the wheel edge. Under some conditions, it may not be possible to reproduce the exact alignment of two opposite cutting edges with the use of one wheel. Further gashing along the front face of each tooth may be necessary to gain adequate chip clearance. It is not necessary for opposite cutting edges to align on a diameter line through the cutter end. The end mill will cut with these edges off-set from the diameter line. In general, take no more than .005 inch crossfeed infeed against the wheel face during rough gumming, using a light cut to finish the job.

B. Salvaging Milling Cutters:

The description of the fluting process parallels that of sharpening a form relieved cutter except for a few important steps. Refer to Figures 68B, 68C, 68D for the following explanation.

1. General Procedure for Salvaging Straight Tooth Milling Cutters:

- (a) Mount a saucer wheel with the straight side facing the rear of the grinder. Mount a wheel guard. Place the wheel axis at 90 degrees to the table, raised sufficiently to allow the bottom of the wheel to clear the cutter.
- (b) Mount the cutter on a workhead arbor or straight arbor between centers so that when the workhead or arbor is mounted on the table the cutter teeth on top face to the front of the machine.
- (c) Examine the cutter gullet radius, and then dress a somewhat smaller radius on the inside wheel O D. edge. Position the cutter under-

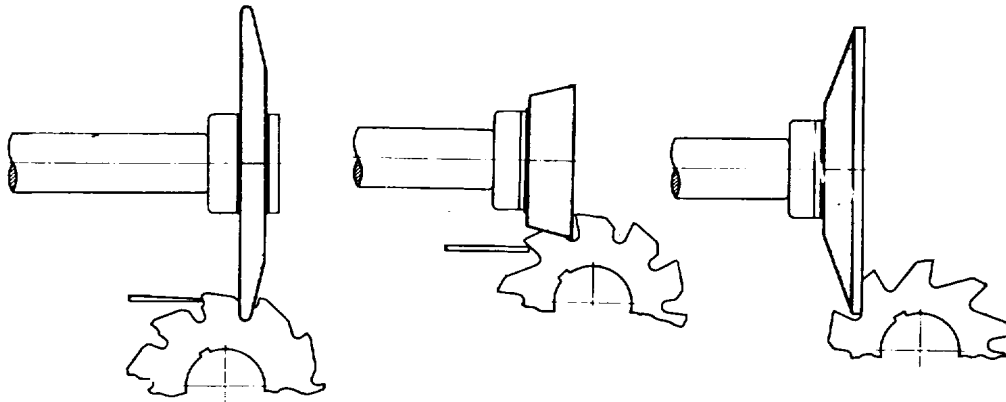
Instruction Manual

Figure 68B
First Operation in
Salvaging a Cutter.

Figure 68C
Third Operation, with a
Worn-Out Cup Wheel,

Figure 68D
Third Operation, with a
Dish Wheel.

neath the wheel, lower the wheel just short of the bottom of a gullet, and using the crossfeed handwheel, place the tooth face at the original rake relative to the wheel. Once the relationship of the wheel side to the tooth face has been set, do not make additional adjustments to the machine crossfeed.

- (d) Set the spring blade micrometer toothrest against a convenient tooth face, or whenever possible, use a toothrest indexing on an index disc. When indexing on the cutter, set the base of the universal toothrest on the table. Extend its crossarm under the mill and adjust the short micrometer toothrest on a tooth face approximately at the same height as the mill's center. Hold the tooth face to be ground against the wheel side while setting the rest blade on the preceding tooth face. If it is necessary to make adjustments of the mill relative to the wheel-during the grinding process, do so only with the micrometer toothrest.
 - (e) The depth of gumming depends on a number of factors, but is primarily determined by necessary chip space. This will be learned by experience. If sufficient material is available, a flute depth approximating that of a new mill of similar size should be created. Take cuts no deeper than .005 inch when lowering the wheel head. Travel rapidly across work so as not to discolor it. Remove as little material as possible on the tooth face during the gumming operation. Grind each tooth in succession.
 - (f) After sufficient flute depth has been created, mount a worn cup wheel and proceed in a similar manner to grind the backs of the teeth to a point that allows maximum chip space without weakening the tooth. (See Figure 68C.) A saucer wheel may also be used (Figure 68D).
 - (g) Make a new set-up for grinding the primary and secondary clearance angles, and grind these according to instructions in Chapter 5.
2. Helical Milling Cutters:

NOTE: The following method is recommended for occasional tool salvage

Instruction Manual

and is not intended to compete with production spiral grinders that grind by template or sine bar camming methods.

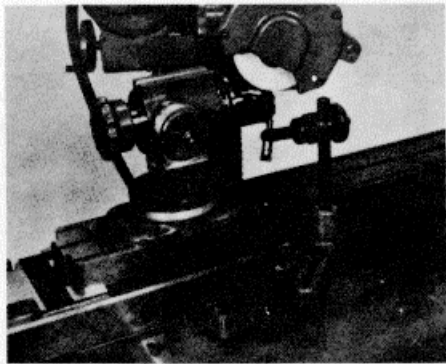


PHOTO 69

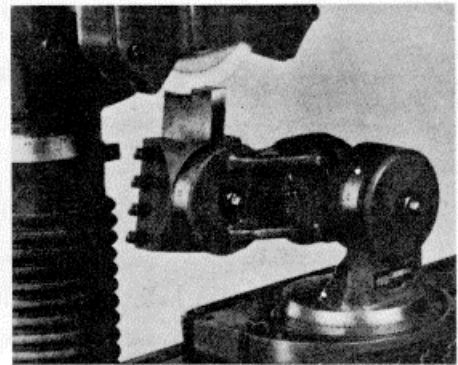


PHOTO 70

- (a) Mount the universal workhead to the left side of the grinder as shown in Photo 69. To facilitate toothrest placement, it may be helpful to off-set toward the machine front the workhead base from the table center. Mount the cutter shank or arbor in the workhead.
- (b) Mount a straight wheel about 5 or 6 inches in diameter, such as the PV5FH60 or PV7GM46. Mount a wheel guard. Since the back side of each tooth forms an angle with the tooth face, it will be necessary to dress the periphery of the wheel relative to its side at this angle. This angle is a straight line always at an angle relative to the mill's axis which is moved along the length of the flute describing a helical plane which is the tooth back. Sight along the mill's axis from the right side of the table in order to determine the approximate angle. The wheel periphery should be wide enough to cover the tooth back. Use the diamond dresser to create the angle on the wheel periphery. Use the abrasive wheel dresser or other means to dress a small radius on the wheel edge at its largest diameter side. The radius size is not important as it will break down in the flutting process, but it must assist in recreating the original gullet, radius, and rake on the tooth face. It is the curved periphery of the wheel edge that generates the radius and curved rake of the cutting face.
- (c) Place the straight wheel at an angle relative to the cutter axis which will be slightly greater than the actual cutter helix. Some experimentation is necessary to place the wheel side, corner radius, and peripheral angle so that it will correspond to the tooth face, gullet radius, and preceding tooth back. Once the alignment of the wheel to the cutter has been made, do not move the machine crossfeed.
- (d) Since rapid lowering of the wheelhead will take place during the grinding, it is necessary to set the fixed toothrest on the front saddle surface rather than on the wheelhead. A special t-slot block (SUCH AS THE B670T SHOWN IN THE PHOTO) or other adapting plate which can hold the base of the universal toothrest is needed. Adjust the crossarm so that the fixed blade of the small micrometer rest is

Instruction Manual

approximately at the center height of the mill and contacting the tooth face just preceding the one on top to be ground by the wheel. The tip of the blade should precede (TO THE LEFT IN THE PHOTO) the wheel periphery at the inside in order to start camming just prior to the wheel contacting the flute end.

- (e) Run the wheel clockwise facing the wheel as it is in the photo. Make cuts no deeper than .005 inch when lowering the wheel head. Follow recommendations in 1-(e) above. Use the same grinding techniques as used when grinding form relieved cutters (See Chapter 9).
- (f) Make a new set-up for grinding the primary and secondary clearance angles, and grind these according to instructions in Chapters 3 and 4.

IV. SURFACE GRINDING OPERATIONS

Limited surface grinding can be accomplished on any tool and cutter grinder or universal grinder. Consult the general specifications of Section Six, Part I, for a listing of surface grinding capacities by model number. When surface grinding on machines with a 4 inch column, set the column lock lever so that it is just possible to lower the wheelhead with the handwheel. Because of the column construction on these grinders, surface finishes will not be as smooth as can be obtained on a machine built only for surface grinding.

- A. The B989 Universal Work Holding Fixture is the standard fixture for holding all kinds of relatively small tools on which surface grinding operations are performed. Photo 70 shows a typical set-up on a tool and cutter grinder for sharpening a slab forming tool. The fixture's four swivel joints allow the tool to be swiveled in three axes for grinding multiple angles. In general, when hogging off metal during roughing operations, do not lower the wheelhead more than .005 Inch for any one pass across the work. Make sure that all wheelhead swivels are tight. Use table transmission in the most direct ratio. A more accurate work thickness is obtained by using light down feed with larger crossfeed, rather than the other way around, due to wheel break down.
- B. Magnetic Chucks:
Permanent or electric magnetic chucks for holding work are available from many suppliers. A five inch by 10 inch capacity is usually all that is desirable, as machine crossfeed capacity rarely exceeds 5 inches even with spindle extensions. Chucks are available with either stationary or tilting top plates. For close work, always indicate the top of a chuck or grind test blocks to check flatness of the top plate surface relative to the machine ways.
- C. Wetwheel guards, specially adapted for surface grinding, are available from the factory upon request.

V. B982 AIR-BEARING FIXTURE FOR END MILLS AND OTHER CUTTERS

NOTE: This workholding fixture is available in two models; B982WB-model with standard sized bushing inserts for the spindle tube; B982-5C - model for use with standard 5C spring collets up to 1." in capacity.

WARNING: Do not move the spindle tube relative to the fixture bearing housing unless the air supply is attached to the fixture and a pressure of at least 50 lbs. is turned on. Doing so will cause wear damage to the spindle and bearings.

Instruction Manual

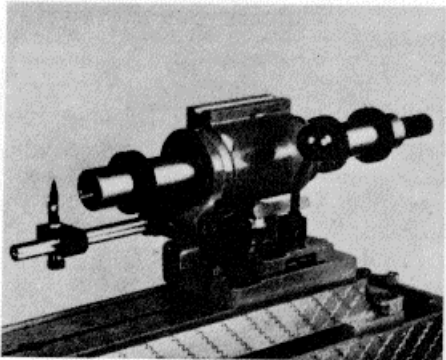


PHOTO 71

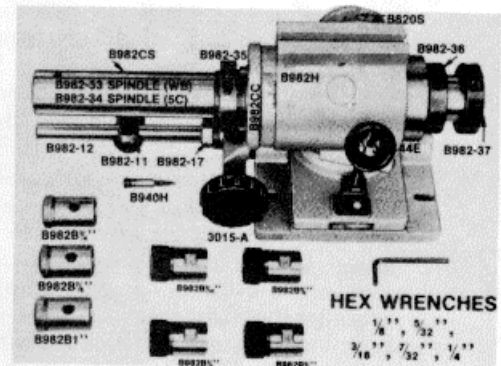


PHOTO 72

- A. Set-up for sharpening the periphery
1. Position the cup wheel as shown in Photo 71. Mount a wheel guard and dress the wheel (See Chapter 3).
 2. Mount the fixture at the right end of the table as shown. Fixture swivels (horizontal and vertical) should be set at '0'. **NOTE:** Precise measurement of the fixture swivels is not necessary. It is not possible to grind a taper since the spindle remains at a constant distance relative to the wheel at any machine crossfeed setting.
 3. Mount the end mill in the fixture spindle using the appropriate size of bushing (**B982B1; B7/8; B3/4; B5/8; B1/2; B3/8; and B3/16**). Photo 72 shows the standard equipment. A 3/16 inch hex wrench is provided to tighten the socket screw in the spindle onto flat of 1", 7/8", 3/4" end mills through the bushing holes. Use the 1/16 inch hex wrench to tighten the socket screws in the 5/8, 1/2, 3/8., 3/16" bushings to the end mill shank. Then tighten the bushings into the spindle end by turning down the 3/16" socket screw in the spindle onto the recessed bushing shank. In a similar manner, lock a 1 1/4" shank into the spindle by set screw when no bushing is used. **DO NOT TIGHTEN THE SET SCREW TOO MUCH - DISTORTION OF THE TUBE END MAY RESULT.** The spindle for the bushing model (**B982-33**) has a bore of 1 1/4 inches, and can accommodate end mills with this size of shank.
 4. When mounting cutters with the 5C collet unit, insert the collet first in the adapter sleeve so that the sleeve key finds the slot in the collet. Turn the collet draw tube sufficiently to catch the threads on the collet, so that the collet is being drawn into the adapter sleeve. Mount the cutter shank into the collet and continue to draw the collet into the fixture until it firmly holds the cutter shank. Now check the O.D. of the cutter for run-out with a dial indicator. Excess run-out can be corrected by loosening the collet sufficiently to rotate the cutter, or by tapping it lightly on the back of a tooth.
 4. Position the toothrest relative to the wheel by first setting the Toothrest Adjustment Collar (**B982CC**) at '0' degrees opposite the casting housing mark. Using the machine crossfeed, head elevation, and cross movement of the Toothrest Arm, position the micrometer blade at the right edge of the cup wheel and the blade end at the approximate center height of the

Instruction Manual

wheel, 1/16 inch to the right of the wheel edge. It is not necessary to unlock the hex nut fastening the Arm (**B982-12**) to the Toothrest Adjustment Collar before moving the arm by means of the knob (**3015-A**). The position of the machine table and the Toothrest Holder (**B982-11**) must be adjusted in order to allow sufficient spindle travel space for the length of the end mill flutes. The toothrest blade end must catch the outer face edge of a tooth and still leave clearance (ON THE ORDER OF 1/32 INCH) between the rest and the wheel. Once the blade is positioned near the wheel, set the two table stops against the stop block to prevent any movement. Adjust the micrometer of the toothrest to bring the tooth face edge to the same height as the center of the fixture. Use the machine height gauge to make this measurement.

5. Set the clearance angle. To do this, rotate the Toothrest Adjustment Collar (**B982CC**) by loosening the top hex socket screw slightly with a 3/16 hex wrench (the bottom two screws should be left just tight enough so that the collar can be swiveled by hand when the top one is loosened). Rotate the collar so that the cutter teeth rotate toward the wheel (clockwise facing the rear of the fixture), the required number of clearance angle degrees. The clearance angle is read directly on the scale on the periphery of the collar.
6. An alternate method of setting the clearance is to use the method employed in Chapter 4, only using the toothrest blade. The blade can be lowered by its micrometer according to the amounts stated in Table II, rather than lowering the machine wheelhead.
7. Set the front Index Collar (**B982-35**) and rear Stop Collar (**B982-36**) on the sliding spindle in order to limit the travel to the right or left. The 1/8 inch wrench loosens these collars. Travel to the right should be just far enough to allow the cutter to escape the toothrest so as to be indexed (ROTATED) for the next tooth.

B. Grinding Procedure

1. Each tooth's land back of the cutting edge is rotated past the wheel edge while sliding on the fixed toothrest. The basic grinding action is the same as when the mill is mounted in a fixed spindle workhead and the table of the machine is moved in order to slide the mill past the wheel. Except in this instance, the operator moves the cutter the full length of the teeth to be ground toward the center of the wheel (past the peripheral grinding edge), by depressing the entire fixture spindle away slightly from the wheel, using the Rocker Arm and Knob (**B982-21**). Then after releasing the lever and lightly touching the wheel with the land to be ground, draw the spindle tube back to the starting position, making sure that the tooth face contacts the finger rest at all times. In other words, keep light clockwise pressure on the spindle when it is retracted during the grinding of each land. In order not to dull the cutting edges, it is best to come off from the toothrest each time a land cut has been completed, prior to indexing to the next tooth. Use the same grinding practices and visual checks described in Chapter 4. Grind a secondary clearance angle on the periphery of the mill by making an additional adjustment of the clearance angle bracket.
2. It is possible to use the air-bearing fixture using the plain wheel method

Instruction Manual

Keep in mind that when this method is employed, each time the Toothrest Adjustment Collar is rotated, or micrometer toothrest lowered, the wheel centerline must be relocated at the same height as that of the cutter center. (See Chapter 1, Section Five). This will usually mean lower the wheelhead a given amount.

3. Use the fixture in the same manner as a fixed spindle workhead for sharpening the ends of the teeth. To accomplish this, set the Toothrest Adjusting Collar (**B982CC**) bracket for '0' degrees rotation and tighten the Index and Stop Collars which will leave the spindle in a convenient position. Depress the Rocker Arm (**B982-21**) to the horizontal position. Turn the fixture spindle about 88 degrees from the longitudinal position, tilt the fixture end downward the required clearance angle for the teeth ends, and lock the vertical and horizontal swivels. Adjust the micrometer toothrest until a tooth edge is the same height as the center of the mill. Loosen the table stops and readjust them as necessary to limit table travel. Grind the teeth ends (**BOTH PRIMARY AND SECONDARY CLEARANCE ANGLES**) according to the instructions in Chapter 4. Gash ends by further depression of the fixture front end, or remove the mill for hand gashing.

C. Maintenance:

1. Do not move the spindle tube when covered with oil or dirt. Clean prior to moving, leave no oil film. Do not attempt to remove the tube, unless rust or dirt has worked into the center of the spindle.
2. Do not polish the bearings with abrasive materials. Keep the spindle tube free from knicks or scratches. Store in a clean dry place.
3. Always use an air line dryer, or water trap. Use at least 50 lbs/sq. inch air (or inert gas) pressure; 80 lbs/sq. inch is ideal.

Instruction Manual Section Six**GENERAL INFORMATION, SPECIFICATIONS, FIXTURES and ACCESSORIES****I. GENERAL SPECIFICATIONS**

UNIVERSAL TOOL AND CUTTER GRINDERS have either a High Speed Standard Spindle (B360, BA960, 82060 and 86060) or a Heavy Duty Spindle (BA962, B2062 and B6062)

TOOL AND CUTTER GRINDERS have a Single Speed Motorized Spindle (Models 8300, BA900 and B2000)

TABLE OF SPECIFICATIONS

SPECIFICATIONS			BA960		B2060			
	B300	B360	BA900	BA962	B2000	B2062	B6060	B6062
Distance Between Tailstocks	17"		22"		32		32"	
Distance Between Centers Mounted in B943 and Tailstock	11"		16"		26"			
Distance Between Collet in B943 and Tailstock	12"		17"		27"			
Distance Between Centers Mounted in B6043/B9043 and Tailstock							26"	24"
Distance Between Collet in B6043/B9043 and Tailstock							27"	25"
Distance Between B946 Chuck Face and Tailstock 1" HOLE THROUGH CHUCK	10 1/2"		15 1/2"		25 1/2"		25 1/2"	23 1/2"
Table Working Surface	3 5/8" x 22 1/2"		5 1/4" x 27 1/4"		5 1-4" x 37 1/4"		5 1/4" x 37 1/4"	
Sub Table	63/8" x 26 1/4"		8" x 36"		8" x 48"		8" x 48"	
Total Cross Feed & Feed Each Rev. of Handwheel (.001" graduation)	4 3/4"-.100"		7 1/4"-.100"		7 1/4"-.100"		8"-.100"	
Table Traverse	10"		14"		20"		20"	
Fast Feed (Direct Drive) PER REVOLUTION Or CRANK	2 3/4"		2 13/16"		2 13/16"		2 13/16"	
Slow Feed PER REVOLUTION OF CRANK	3:1 RATIO 15/16"		5:1 RATIO 9/16"		5:1 RATIO 9/16"		5:1 RATIO 9/16"	
Swing Over Table (1" AND 2" RAISING BLOCKS AVAILABLE)	8 1/4"		8 1/4"		8 1/4"		12 1/4"	

Minimum Distance Centerline of Wheel Shaft to Top of Table	3 3/4"		3 3/4"		3 3/4"		5 3/4"	
Maximum Distance Centerline of Wheel Shaft to Top of Table	10 3/4"		10 3/4"		10 3/4"		15 1/4"	
Maximum Distance from Column to Outside of Straight Wheel; Dovetail Slide Not Extended, Spindle 90° to Table			3 3/4"		3 3/4"			
	4 3/4"	3 3/4"	4 1/8"	4 1/2"	4 1/8"	4 1/2"	4 5/8"	6"
Maximum Distance from Column to Outside of Straight Wheel, Dovetail Slide Extended, Spindle 90° to Table			9 15/16"		9 15/16"			
	9 15/16"		10 11/16"		10 11/16"		9 3/4"	11 1/2"
Centerline Height of Fixtures to Top of Table	4.130"		4.130"		4.130"		6.130"	
Table T-Slot	7/16"		7/16"		7/16"		7/16"	
Table Swivels	225°		225°		225°		225°	
Wheel Head Swivel	360°		360°		360°		360°	
Column Diameter	4"		4"		4"		6"	
Vertical Movement of Column EACH REVOLUTION OF HANDWELL GRADUATED IN .001"	7"-.040"		7"-.040"		7"-.040"		10 1/2"-.050"	
Motor Speed RPM (Tool Grinders and Universal Grinders)	3450		3450		3450		3450	
			3450-18,400		3450-18,400		3450-17250	
Spindle Speed Range RPM (Universal Models Only)	3450-18,400		1150-7760		1150-7760		2840-53)0	
Maximum I.D. Depth HOLE SIZE 5/32" TO 2" CAPACITY WITH STANARD ARBORS	1 1/4"-2 3/4"		1 1/4"-2 3/4"		1 1/4"-2 3/4"		1 1/4"-2 3/4"	
Maximum Crossfeed Surface Grinding HIGH SPEED SPINDLE 5" WHEEL	2 3/4"		BA960-2 3/4"		B2060-2 3/4"		B6060-3"	
Maximum Crossfeed Surface Grinding HEAVY DUTY SPINDLE 7" OR 8" WHEEL			BA962-4 1/4"		B2062-4 1/4"		B6062-5"	
Maximum Crossfeed Surface Grinding WITH S1055CR QUILL WITH 7" WHELL			5 3/4"		5 3/4"			
Maximum Crossfeed Surface Grinding TOOL GRINDER 6" x 1/2' WHEEL	B300-4 1/8"		BA900-4 1/8"		B2000- 4 1/8"			
Grinding Wheel Hole Size	5/8"	5/8"	5/8"	5/8-1 1/4"	5/8"	5/8-1 1/4"	5/8"	5/8-1 1/4"
Floor Space for Operating	32" x 37"		40" x 52"		40" x 60"		46" x 60"	
Maximum Height of Machine with Column Extended	60 1/4"	63 3/4"	60 1/4"	63 3/4"	60 1/4"	63 3/4"	63 3/4"	
Net Weight (Pounds)	5101	560	1080	1140	1120	1180	1280	

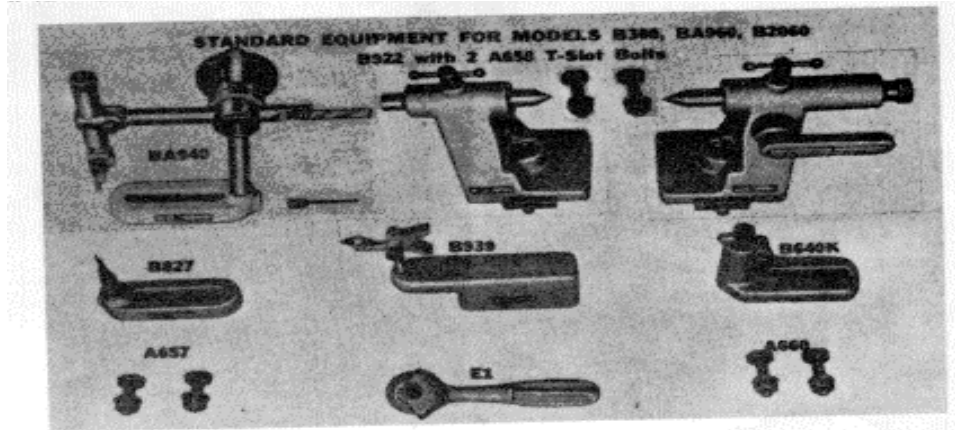
Instruction Manual

II. MACHINE STANDARD EQUIPMENT

A. UNIVERSAL TOOL AND CUTTER GRINDER

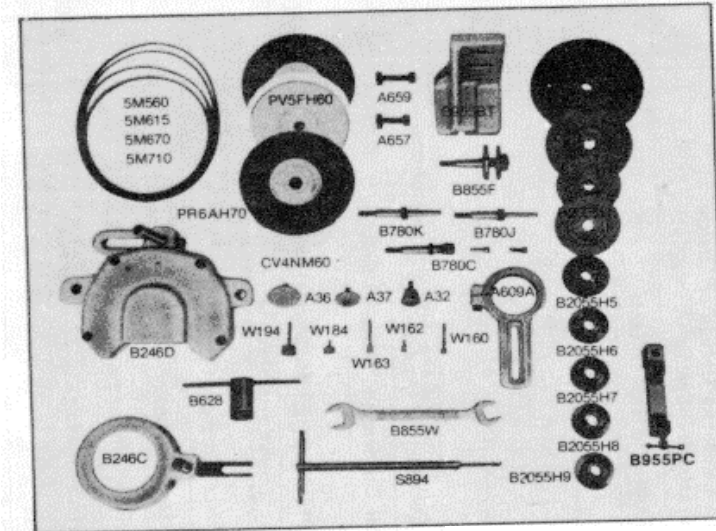
MODELS

- B360**
- BA960**
- BA962**
- B2060**
- B2062**



STANDARD EQUIPMENT FOR MODELS B360, BA960, B2060
A657 T-Slot Bolt, A660 T-Slot Bolt, B640K Diamond Dresser, B827 Plain Tooth Rest, B922 Tailstocks (Matched Set), B939 Center Gauge, BA940 Universal Tooth Rest, B955 Universal Head, E1 Wheel Dresser.

MODELS B360, BA960, B2060



STANDARD EQUIPMENT FOR B955 UNIVERSAL GRINDING HEAD

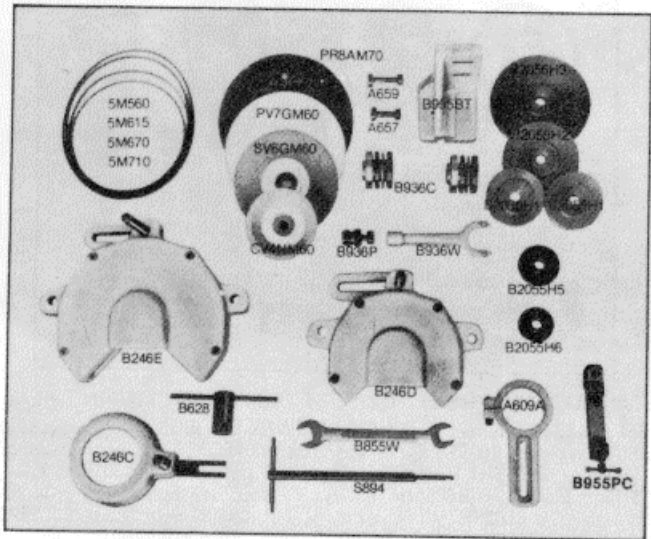
A609A T-Slot Arm, A657 T-Slot Bolt, A659 T-Slot Bolt, B246C Wheel Guard 4", B246D Wheel Guard 6", B628 Wrench, B780C Collet Chuck Assembly, includes B780CD 1/8" and B780CE 1/4" Collets, B780J heel Arbor (5-40), B780K Wheel Arbor (1/4-28), B855F Pulley and Wheel Arbor Assembly (5/8" hole, wheels up to 3/8" wide), B855W Wrench, B960G Belt Guard, B923G Motor, B955BT Bracket for Wheel Guard or Tooth Rest, B955PC Dovetail Clamp Assembly, B6055B Quill Assembly, B2055H1 V-Pulley 3 3/8." (2), B2055H2 V-Pulley 4 1/2", B2055H3 V-Pulley 6", B2055H5 V-Pulley 2 3/8" B2055H6 V-Pulley 2", B2055H7 V-Pulley 1 1/2", B2055H8 V-Pulley 1 1/4", B2055H9 V-Pulley 1 1/8", S894 Hex Wrench, A32 Mounted Cup Wheel, A36 Mounted Wheel, A37 Mounted Wheel, W160 Mounted Wheel, W162 Mounted Wheel, W163 Mounted Wheel, W184 Mounted Wheel, W194 Mounted Wheel, CV4NM60 Cup Wheel, PR6AH70 Cut Off Wheel, PV5FH60 Straight Wheel, SV6GM60 Saucer Wheel, 5M560 V-Belt 22", 5M615 V-Belt 24", 5M670 V-Belt 26", 5M710 V-Belt 28".

Instruction Manual

11. MACHINE STANDARD EQUIPMENT

A. UNIVERSAL TOOL AND CUTTER GRINDER (Cont.)

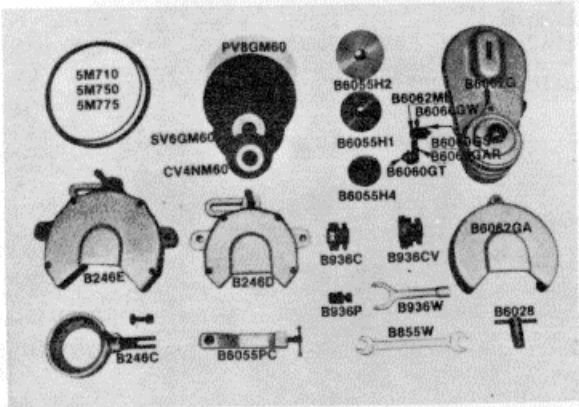
MODELS BA962 AND B2062



STANDARD EQUIPMENT FOR B955HD UNIVERSAL GRINDING HEAD

A609A T-Slot Arm, **A657** T-Slot Bolt, **A659** T-Slot Bolt, **B246C** Wheel Guard 4", **B246D** Wheel Guard 6", **B246E** Wheel Guard 8", **B628** Wrench, **B855W** Wrench, **B923G** Motor, **B936C** Collet (2), **B936CB** Body, **B936CS** Wheel Spacer, **B936CW** Collet Keyed Washer, **B936CN** Nut, **B936P** Puller, **B936W** Wrench, **B955BT** Bracket for Wheel Guard or Tooth Rest, **B955PC** Dovetail Clamp Assembly, **B2055H1** V-Pulley 3 3/8" (2), **B2055H2** V-Pulley 4 1/2", **B2055H3** V Pulley 6", **B2055H5** V-Pulley 2 3/8", **B2055H6** V-Pulley 2", **CV4NM60** Cup Wheel, **PR8AM70** Cut Off Wheel, **PV7GM60** Plain Wheel, **SV6GM60** Saucer Wheel, **S894** Hex Wrench, **S6055CL** Quill Assembly, **5M560** V-Belt 22", **5M615** V-Belt 24", **5M670** V-Belt 26", **5M710** V-Belt 28".

MODELS B6060 AND B6062



STANDARD EQUIPMENT FOR MODELS B6060 AND B6062

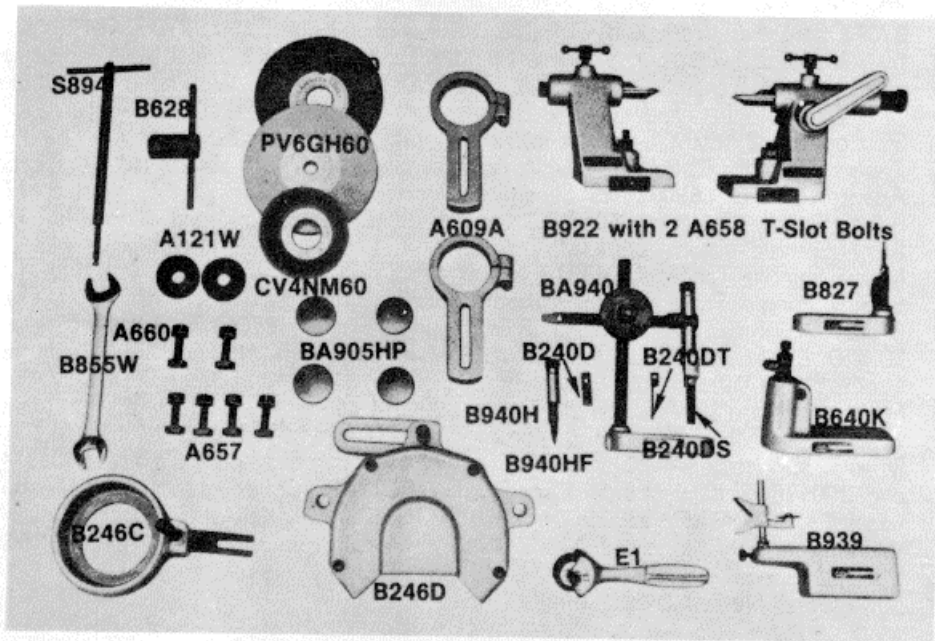
B6022 Matched Tail Stock Set, **B6027** Plain Tooth Rest, **B6039** Center Gauge, **B6040** Universal Tooth Rest, **B6040K** Diamond Dresser, **B6055** Universal Grinding Head (B6060), **B6055HD** Univ. Grinding Head (B6062), **E1** Wheel Dresser, **S894** Hex Wrench.

Instruction Manual

II. MACHINE STANDARD EQUIPMENT

B. TOOL AND CUTTER GRINDERS

MODELS B300, BA900, B2000



A609A T-Slot Arm, **A657** T-Slot Bolt (4), **A660** T-Slot Bolt (2), **B246C** Wheel Guard 4", **B246D** Wheel Guard 6", **B628** Wrench, **B640K** Diamond Dresser, **B827** Plain Tooth Rest, **B855W** Wrench, **B922** Tailstocks (Matched Set) with two A258 T-Slot Bolts, **B923G** Motor Assembly, **B939** Center Gauge, **BA940** Universal Tooth Rest (B940H Micrometer Tooth Rest Blades B240D, B240DS, B240DT, B940HF), **E1** Wheel Dresser, **CV4NM60** Cup Wheel, **PV6GH60** Straight Wheel, **SV6GCM60** Saucer Wheel.

C. ADDITIONAL STANDARD EQUIPMENT FOR HYDRAULIC MACHINES

S891 Extension Wrench for Stop and Reversing Screws.

III. TOOLING, FIXTURES AND ACCESSORIES

A. WORKHEADS FOR MODEL SERIES B300, B360, BA900, BA960, BA962, B2000, B2060, B2062:

B942 Sensitive Workhead with No. 11 B & S Spindle Taper, **B942XM** Sensitive Workhead with No 5 Morse Spindle Taper, **B942XB** Sensitive Workhead with No. 12 B&S Spindle Taper, **B942XB11** Sensitive Workhead with No. 11 B&S Spindle Taper (Index Disc mounted at rear. Uses B641 Collet Fixture with 5C Collets), **B992** Large Sensitive Workhead with No 50MM Spindle Taper (**B792F** No. 50MM to 40MM, Adapter Sleeve, **B792G** No. 50MM to No 11 B & S Adapter Sleeve), **B943** Motor (A C) Driven Workhead with No. 11 B & S Spindle Taper, **B943M5** Motor (A.C) Driven Workhead with No. 5 Morse Spindle Taper, **B943B12** Motor (A.C) Driven Workhead with No. 12 B&S Spindle Taper, **B2043** Variable Speed (@ 25-425 RPM) Motor (D.C.) Driven

Instruction Manual

Workhead with No. 11 B & S Spindle Taper, **B2043M5** Variable Speed Motor (DC) Driven Workhead with No 5 Morse Spindle Taper, **B2043B12** Variable Speed Motor (D.C) Driven Workhead with No 12 B & S Spindle Taper.

B. WORKHEADS FOR MODEL SERIES B6060 AND B6062:

B7042 Sensitive Workhead with No. 11 B & S Spindle Taper, **B7042XM** Sensitive Workhead with No. 5 Morse Spindle Taper, **B7042XB** Sensitive Workhead with No. 12 BGS Spindle Taper, **B7042XB11** Sensitive Workhead with No. 11 B&S Spindle Taper (Index Discs mount at rear; B641 Collet Fixture for 5C Collets), **B9092M** Sensitive Workhead with 50MM and No. 5 Morse Spindle Tapers (**B792F** 50MM to 40MM Adapter Sleeve, **B792G** 50MM to 11 B & S Adapter Sleeve), **B9092B&S** Sensitive Workhead with No. 50MM and No. 12 B & S Spindle Tapers, **B6043** Motor (A.C.) Driven Workhead with No. 11 B & S Spindle Taper, **B6043M5** Motor (A.C.) Driven Workhead with No. 5 Morse Spindle Taper, **B6043B12** Motor (A.C.) Driven Workhead with No. 12 B & S Spindle Taper, **B7043** Variable Speed (@ 50-450 RPM) Motor (D.C.) Driven Workhead with No. 11 B & S Spindle Taper, **B7043M** Variable Speed 50-450 RPM) Motor (D.C) Driven Workhead with No. 5 Morse Spindle Taper, **B7043B12** Variable Speed (@ 50-450 RPM) Motor (D.C.) Driven Workhead with No. 12 B & S Spindle Taper, **B9043M** Motor (A.C.) Driven Workhead with No. 50MM and No. 5 Morse Spindle Taper, **B9043B&S** Motor (A.C.) Driven Workhead with No 50MM and No. 12 BGS Spindle Taper (**B9043M** and **B9043B&S** have standard speed of 250 RPM. Other speeds available on request.) **B10043M** Variable Speed (@ 10-370 RPM) Motor (D.C.) Driven Workhead with No 50MM and No. 5 Morse Spindle Tapers, **B10043B&S** Variable Speed (@ 10-370 RPM) Motor (D.C.) Driven Workhead with No. 50MM and No. 12 B S Spindle Tapers.

C. Coolant Systems (may be retro-fitted by customer; state model, serial number, and voltage):

B935 Coolant Attachment (wheels up to 7" x 1/2"), fits all BA900, BA960, and BA962 series. **B2035** Coolant Attachment (wheels from 5" to 7" x 1/2"), fits all B2000, B2060, and B2062 series. **B6035** Coolant Attachment (wheels from 5" to 7" x 1/2"), fits all B6060 and B6062 series **B6035HD** Heavy Duty Coolant Attachment (wheels up to 8" x 3/4"), fits all B6062 series.

D. **B876** 3" Column Extension for machines with 4" column.

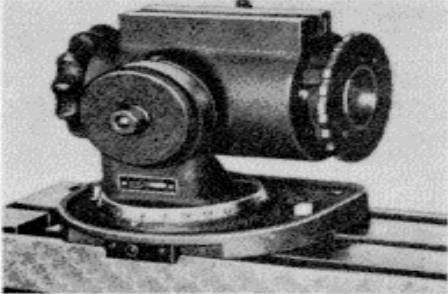
E. Special Toothrest Slide Blade and Arm for use with formed cutters with low helix- up to @ 20°; **B670RB** Blade; **B670T** Arm. See Photo 38, page 51, for use with BA940 or B6040 toothrests.

F. Special wheel guards available on request.

Instruction Manual

III. TOOLING, FIXTURES AND ACCESSORIES

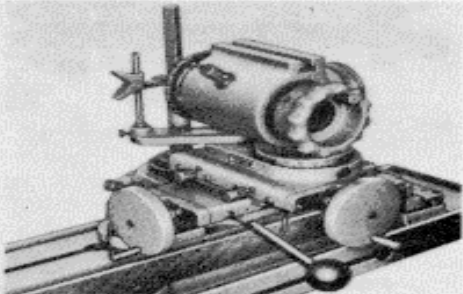
Consult the Universal Tool and Cutter Grinding Catalog for complete listings of all Models and Sizes.



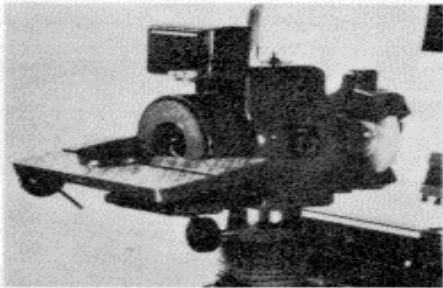
**B942
SENSITIVE WORKHEAD**



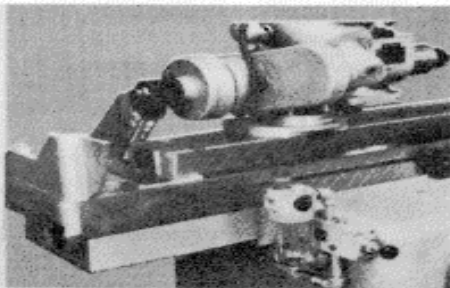
**B943
MOTOR DRIVEN WORKHEAD**



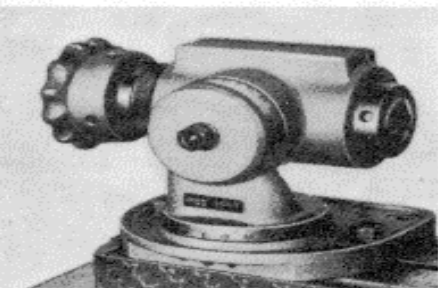
**BA986
RADIAL GRINDING FIXTURE**



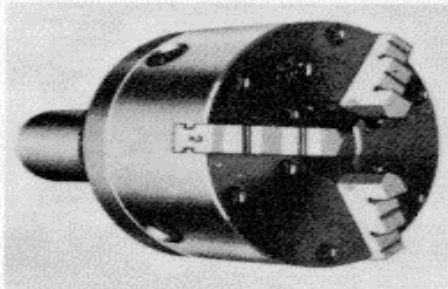
**B945
TABLE ATTACHMENT**



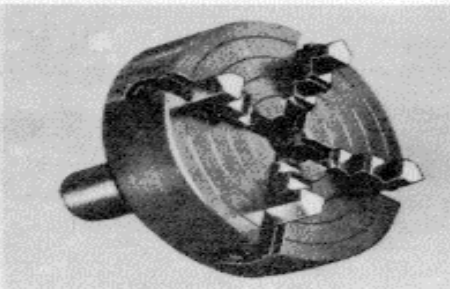
**B1094HS
AIR COLLET CLOSURE**



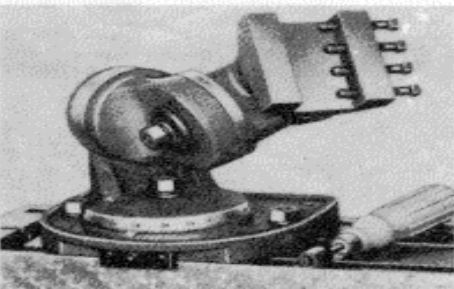
**B947
TAP GRINDING FIXTURE**



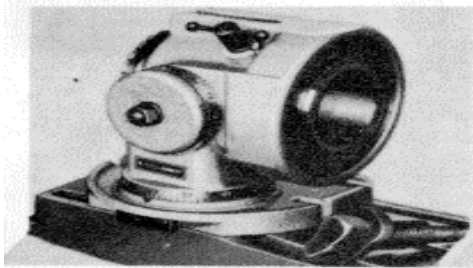
**CHUCKS
B944 4" 6-JAW ADJUSTRU
B946 4" 3-JAW ADJUSTRU**



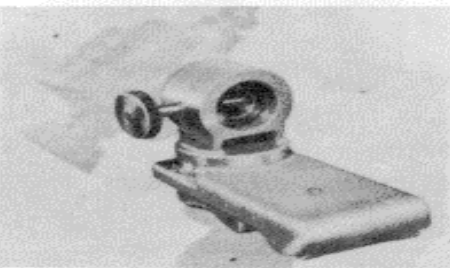
**B844E 6" INDEPENDENT
4-JAW CHUCK
NO. 11 B&S ARBOR**



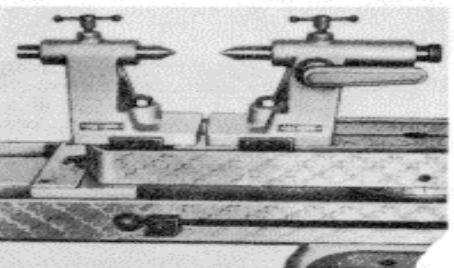
**B989 UNIVERSAL
WORK HOLDING FIXTURE
STD. VISE 1-1/12'**



**B292
SENSITIVE WORKHEAD**



**B979 UNIVERSAL
ANGULAR MOTOR MOUNT
-101-**

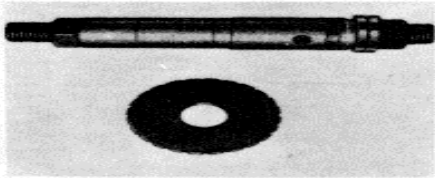


**B922 TAILSTOCKS
(MATCHED SET)**

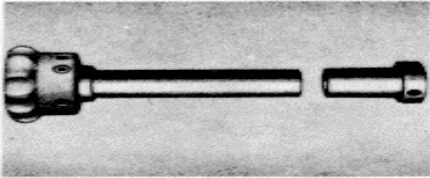
Instruction Manual

III. TOOLING, FIXTURES AND ACCESSORIES

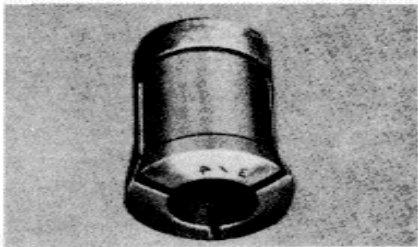
Consult the Universal Tool and Cutter Grinding Catalog for complete listings of all Models and Sizes.



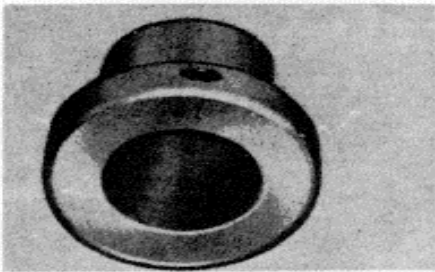
**B648D INDEX DISCS
24 UP TO 60 DIVISIONS
B948 SERIES CUTTER AND
HOB GRINDING ARBORS**



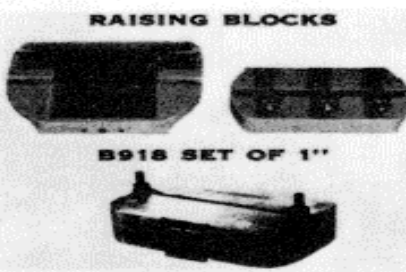
**B641 COLLET FIXTURE
FOR B943, B2043, B6043
B941 COLLET FIXTURE
FOR B942 AND B6402**



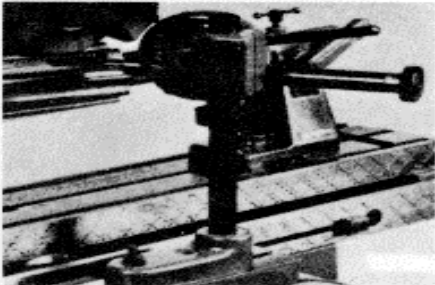
**B641C 5C COLLETS
FOR B641 & B941 FIXTURES**



**B641K
STRAIGHT SLEEVES
11 B & S O.D. TAPER**



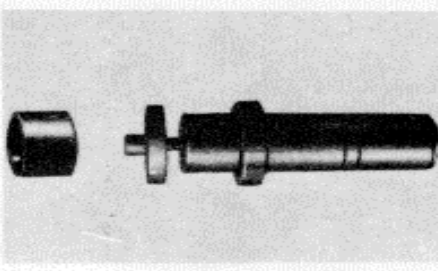
**RAISING BLOCKS
B918C SET OF 1"
B9018C 1" RAISING BLK.
B9018C2 2" RAISING BLK.
B9018C3 3" RAISING BLK.**



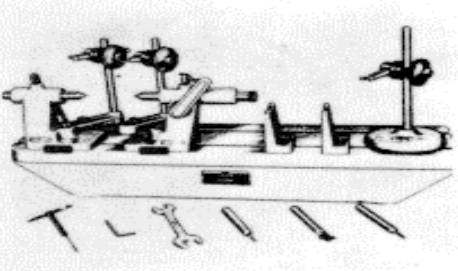
**B1070
GRINDING FIXTURE**



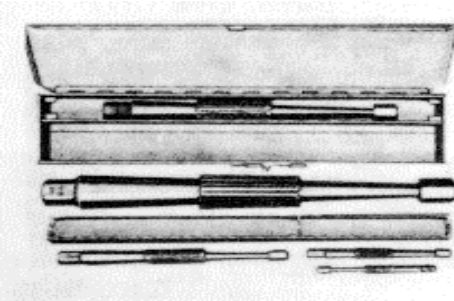
**B988 UNIVERSAL
PLAIN CUTTER HOLDER**



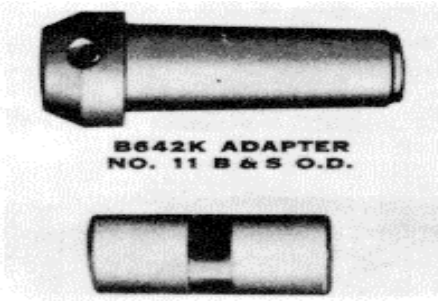
**SHELL END MILL
AND CUTTER ARBOR
5/8" TO 1-1/2"**



**BC3 BENCH CENTER AND
SURFACE PLATE**

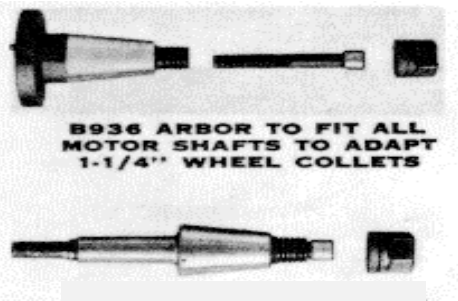


**EXPANDING MANDRELS
HOLES 3/8" TO 5-1/2"**



**B642K ADAPTER
NO. 11 B & S O.D.**

**B642T TAPER SLEEVES
NO. 11 B & S TAPER O.D.**



**B936 ARBOR TO FIT ALL
MOTOR SHAFTS TO ADAPT
1-1/4" WHEEL COLLETS**

**B936B ARBOR TO ADPAT
B855, B955 QUILL FOR
1-1/4" WHEEL COLLETS**

IV. MACHINE ADAPTABILITY

A. ADAPTING A MACHINE WITH HEAVY DUTY GRINDING HEAD TO USE A HIGH SPEED SPINDLE.

FOR BA962 AND B2062 SERIES ORDER:

- | | | | |
|---|------------------------------|---|--|
| 1 | B1 6055B Spindle | 1 | B2055H9 Pulley |
| 1 | B855F Pulley and Wheel Arbor | 1 | B780J I.D. Arbor /4" Wheel |
| 1 | B2055H7 Pulley 1 | 1 | B780K I.D. Arbor ha" Wheel |
| 1 | B2055H8 Pulley 1 | 1 | B780C Arbor & Collet for /.", Y" Wheel |

FOR 86062 SERIES ORDER:

- | | | | |
|---|---|---|----------------|
| 1 | B6055A Spindle 1 | 1 | B6055H3 Pulley |
| 1 | B6055F Pulley and Wheel Arbor | 1 | B6055H5 Pulley |
| 1 | B6055C Collet Chuck Assembly
1/8", 1/4" Wheels | 1 | B6055H6 Pulley |
| 1 | B6055JS I D Arbor 1/8" Wheels | 1 | B6055H7 Pulley |
| 1 | B6055JL I.D Arbor 1/8" Wheels | 1 | B6055H8 Pulley |

B. ADAPTING A MACHINE WITH A STANDARD GRINDING HEAD TO USE A HEAVY DUTY SPINDLE

FOR BA960 AND 82060 SERIES ORDER:

- | | | | |
|---|-----------------|---|----------------|
| 1 | S6055CL Spindle | 1 | B246E 8" Guard |
| 1 | B936CL Collet 1 | 1 | B936W Wrench |
| 1 | B936P Puller | | |

FOR B6060 SERIES ORDER:

- | | | | |
|---|-------------------------------|---|----------------------------------|
| 1 | B6062A Spindle 1 | 1 | B246E 8" Guard |
| 1 | B936CV Collet and Pulley 2Y4" | 1 | B936C Collet (right hand thread) |

C. ADAPTING A TOOL AND CUTTER GRINDING MACHINE TO BECOME A UNIVERSAL GRINDER

FOR B300, BA900, B2000 SERIES ORDER:

- 1 B955 Universal Grinding Head less present motor - B923()-on machine.
- 1 B955HD Heavy Duty Universal Grinding Head less present motor-B923()

V. REPAIR KITS AND ORDERING PARTS

HYDRAULIC CYLINDER REPAIR KITS FOR MACHINE MODELS BA900, BA960, BA962, B2000, B2060, B6060, B6062 SERIES: ORDER (1) B4034RK; B5034RK (obsolete cylinders).

INSTRUCTIONS FOR ORDERING PARTS WHEN CONTACTING THE FACTORY OR A DISTRIBUTOR, YOU WILL RECEIVE BETTER SERVICE IF YOU:

1. State the model and serial number of the machine, and the date of purchase.
2. Give the part number, description and quantity for each item as determined from our catalog parts list and price sheets. For motor operated units, state voltage, phase and speed range desired.
3. State the shipping address and the method of transportation desired.

I. TABLES OF REFERENCE
CLEARANCE ANGLES--STRAIGHT WHEELS

Relief Tables for High-Speed Steel Cutters
I-Using Straight Wheels

C = Distance in inches to set center of cutter and tip of tooth rest below (or above) center of wheel when grinding with a straight wheel.

Wheel Diameter (Inches)	C for 4° Relief Angle	C for 5° Relief Angle	C for 6° Relief Angle	C for 7° Relief Angle
3	.104	.131	.157	.183
3 ¼	.113	.141	.170	.198
3 ½	.122	.152	.183	.213
3 ¾	.131	.163	.196	.227
4	.139	.174	.209	.242
4¼	.150	.185	.222	.259
4½	.157	.195	.235	.274
4¾	.165	.207	.248	.289
5	.174	.218	.261	.305
5¼	.183	.228	.274	.319
5 ½	.191	.239	.287	.335
5 ¾	.200	.250	.300	.350
6	.209	.261	.313	.365
6¼	.218	.272	.326	.381
6½	.226	.283	.339	.396
6¾	.235	.294	.352	.411
7	.244	.305	.365	.426

II. CLEARANCE ANGLES-CUP WHEELS

II-Using Cup Wheels

C = Distance in inches to set tip of tooth rest below or above center of cutter when grinding the peripheral teeth of cutters with a cup wheel.

Wheel Diameter (Inches)	C for 4° Relief Angle	C for 5° Relief Angle	C for 6° Relief Angle	C for 7° Relief Angle
1/2	.017	.022	.026	.031
3/4	.026	.033	.040	.046
1	.035	.044	.053	.061
1 1/4	.044	.055	.066	.077
1 1/2	.052	.066	.079	.092
1 3/4	.061	.076	.092	.108
2	.070	.087	.105	.123
2 1/2	.087	.109	.131	.153
2 3/4	.096	.120	.144	.168
3	.104	.131	.158	.184
3 1/2	.122	.153	.184	.215
4	.139	.174	.210	.245
4 1/2	.157	.197	.237	.276
5	.174	.219	.263	.307
5 1/2	.192	.241	.289	.338
6	.207	.262	.315	.368

III. CLEARANCE ANGLES-REAMERS

Vertical Adjustment of Tooth-rest for Grinding Clearance on Reamers

Size of Reamer	Hand Reamer for Steel. Cutting Clearance Land 0.006 inch Wide		Hand Reamer for Cast Iron and Bronze. Cutting Clearance Land 0.025 inch Wide		Chuckling Reamer for Cast Iron and Bronze. Cutting Clearance Land 0.025 inch Wide		Rose Chuckling Reamers for Steel For Cutting Clearance on Angular Edge at End
	For Cutting Clearance	For Second Clearance	For Cutting Clearance	For Second Clearance	For Cutting Clearance	For Second Clearance	
1/2	0.012	0.052	0.032	0.072	0.040	0.080	0.080
5/8	0.012	0.062	0.032	0.072	0.040	0.090	0.090
3/4	0.012	0.072	0.035	0.095	0.040	0.100	0.100
7/8	0.012	0.082	0.040	0.120	0.045	0.125	0.125
1	0.012	0.092	0.040	0.120	0.045	0.125	0.125
1 1/8	0.012	0.102	0.040	0.120	0.045	0.125	0.125
1 1/4	0.012	0.112	0.045	0.145	0.050	0.160	0.160
1 3/8	0.012	0.122	0.045	0.145	0.050	0.160	0.175
1 1/2	0.012	0.132	0.048	0.168	0.055	0.175	0.175
1 5/8	0.012	0.142	0.050	0.170	0.060	0.200	0.200
1 3/4	0.012	0.152	0.052	0.192	0.060	0.200	0.200
1 7/8	0.012	0.162	0.056	0.196	0.060	0.200	0.200
2	0.012	0.172	0.056	0.216	0.064	0.224	0.225
2 1/8	0.012	0.172	0.059	0.219	0.064	0.224	0.225
2 1/4	0.012	0.172	0.063	0.223	0.064	0.224	0.225
2 3/8	0.012	0.172	0.063	0.223	0.068	0.228	0.230
2 1/2	0.012	0.172	0.065	0.225	0.072	0.232	0.230
2 5/8	0.012	0.172	0.065	0.225	0.075	0.235	0.235
2 3/4	0.012	0.172	0.065	0.225	0.077	0.237	0.240
2 7/8	0.012	0.172	0.070	0.230	0.080	0.240	0.240
3	0.012	0.172	0.072	0.232	0.080	0.240	0.240
3 1/8	0.012	0.172	0.075	0.235	0.083	0.240	0.240
3 1/4	0.012	0.172	0.078	0.238	0.083	0.243	0.245
3 3/8	0.012	0.172	0.081	0.241	0.087	0.247	0.245
3 1/2	0.012	0.172	0.084	0.244	0.090	0.250	0.250
3 5/8	0.012	0.172	0.087	0.247	0.093	0.253	0.250
3 3/4	0.012	0.172	0.090	0.250	0.097	0.257	0.255
3 7/8	0.012	0.172	0.093	0.253	0.100	0.260	0.255
4	0.012	0.172	0.096	0.256	0.104	0.264	0.260
4 1/8	0.012	0.172	0.096	0.256	0.104	0.264	0.260
4 1/4	0.012	0.172	0.096	0.256	0.106	0.266	0.265
4 3/8	0.012	0.172	0.096	0.256	0.108	0.268	0.265
4 1/2	0.012	0.172	0.100	0.260	0.108	0.268	0.265
4 5/8	0.012	0.172	0.100	0.260	0.110	0.270	0.270
4 3/4	0.012	0.172	0.104	0.264	0.114	0.274	0.275
4 7/8	0.012	0.172	0.106	0.266	0.116	0.276	0.275
5	0.012	0.172	0.110	0.270	0.118	0.278	0.275

IV. CLEARANCE ANGLES-CARBIDE REAMERS

RECOMMENDED PRIMARY (RELIEF) & SECONDARY (CLEARANCE) ANGLES:

Reamer Diameter	Relief Angle	Clearance Angle
1/4" to 3/8"	20° to 15°	40° to 30°
3/8" to 5/8"	15° to 10°	30° to 20°
5/8" to 1"	10° to 8°	20° to 16°
1" to 1 1/2"	8° to 6°	16° to 12°
Over 1 1/2"	6°	12°

RECOMMENDED CIRCULAR LAND WIDTHS

.0051"-.010"	.010"-.020"	.020" plus
Aluminum bronze Low lead bronze Copper Magnesium Steel-heat treated Steel forgings Bakelite Hard rubber	Aluminum castings not heat treated Free cutting steel Free cutting brass Cast iron Die castings Bearing bronze	Heat treated aluminum Babbitt

V. STANDARD CLEARANCE ANGLE SETTINGS FOR H.S.S. CUTTERS AND FOR CARBIDE FACE MILLS

Cutter	Tool Material	Work Material		
		Steel	Cast Iron	Nonferrous and Nonmetallics
Peripheral or O.D. Cutting Edge	High Speed Steel	5° to 10°	5° to 10°	7° to 12°
	Cast Alloy	4 to 6°	4° to 6°	5° to 10°
	Cemented Carbides	4° to 6° 4° to 6°	5° to 10°	
Side or End Cutting Edges	All	1° to 4°	1° to 4°	2° to 7°

*Smaller diameter cutters require larger relief angles.

VI. CLEARANCE ANGLES-CORNER

After determining the necessary clearance angle and corner angle, read the correct settings for radial roll and axial tilt of the universal workhead at the horizontal and vertical intersection of these values. EXAMPLE: For 7 degrees of clearance and a 45 degree corner angle, the radial roll is 5 degrees and the axial tilt is 5 degrees. To set the radial roll, consult the clearance angle table for cup wheels. Set the axial tilt on the upper swivel of the workhead.

This table is included as an alternate method obtaining the clearance angle on the chamfer of shell end mills, face mills, and other similar tools. In many instances, adequate clearance can be obtained by swiveling the workhead to the necessary corner angle and then tilting the wheelhead or workhead to the desired primary or secondary angle of these lands at the periphery or face of the cutter.

CORNER ANGLE

		5°		10°		15°		20°		22½°		25°		30°		35°		40°		45°				
		Rad roll	Axial tilt	Rad roll	Axial tilt	Rad roll	Axial tilt	Rad roll	Axial tilt	Rad roll	Axial tilt	Rad roll	Axial tilt	Rad roll	Axial tilt	Rad roll	Axial tilt	Rad roll	Axial tilt	Rad roll	Axial tilt	Rad roll	Axial tilt	
DESIRE D TRUE C L E A R A N C E A N G L E	½°	0	0.5	0.1	0.5	0.1	0.5	0.2	0.5	0.2	0.5	0.2	0.5	0.3	0.4	0.3	0.4	0.3	0.4	0.4	0.4	0.4	0.4	½°
	1°	0.1	1.0	0.2	1.0	0.3	1.0	0.3	0.9	0.4	0.9	0.4	0.9	0.5	0.9	0.6	0.8	0.6	0.8	0.7	0.7	0.7	0.7	1°
	1½°	0.1	1.5	0.3	1.5	0.4	1.5	0.5	1.4	0.6	1.4	0.6	1.4	0.8	1.3	0.9	1.2	1.0	1.1	1.1	1.1	1.1	1.1	1½°
	2°	0.2	2.0	0.3	2.0	0.5	1.9	0.7	1.9	0.8	1.8	0.8	1.8	1.0	1.7	1.2	1.6	1.3	1.5	1.4	1.4	1.4	1.4	2°
	2½°	0.2	2.5	0.4	2.5	0.6	2.4	0.9	2.4	1.0	2.3	1.1	2.3	1.2	2.2	1.4	2.1	1.6	1.9	1.8	1.8	1.8	1.8	2½°
	3°	0.3	3.0	0.5	3.0	0.8	2.9	1.0	2.8	1.2	2.8	1.3	2.7	1.5	2.6	1.7	2.5	1.9	2.4	2.1	2.1	2.1	2.1	3°
	3½°	0.3	3.5	0.6	3.4	0.9	3.4	1.2	3.3	1.3	3.2	1.5	3.2	1.8	3.0	2.0	2.9	2.3	2.7	2.5	2.5	2.5	2.5	3½°
	4°	0.3	4.0	0.7	3.9	1.0	3.9	1.4	3.8	1.5	3.7	1.7	3.6	2.0	3.5	2.3	3.3	2.6	3.1	2.8	2.8	2.8	2.8	4°
	4½°	0.4	4.5	0.8	4.4	1.2	4.3	1.5	4.2	1.7	4.2	1.9	4.1	2.3	3.9	2.6	3.7	2.9	3.5	3.2	3.2	3.2	3.2	4½°
	5°	0.4	5.0	0.9	4.9	1.3	4.8	1.7	4.7	1.9	4.6	2.1	4.5	2.5	4.3	2.9	4.1	3.2	3.8	3.5	3.5	3.5	3.5	5°
	5½°	0.5	5.5	1.0	5.4	1.4	5.3	1.9	5.2	2.1	5.1	2.3	5.0	2.8	4.8	3.2	4.5	3.5	4.2	3.9	3.9	3.9	3.9	5½°
	6°	0.5	6.0	1.0	5.9	1.6	5.8	2.1	5.6	2.3	5.6	2.5	5.4	3.0	5.2	3.5	4.9	3.9	4.6	4.3	4.3	4.3	4.3	6°
	6½°	0.6	6.5	1.1	6.4	1.7	6.3	2.2	6.1	2.5	6.0	2.8	5.9	3.3	5.6	3.8	5.3	4.2	5.0	4.6	4.6	4.6	4.6	6½°
	7°	0.6	7.0	1.2	6.9	1.8	6.8	2.4	6.6	2.7	6.5	3.0	6.4	3.5	6.1	4.0	5.8	4.5	5.4	5.0	5.0	5.0	5.0	7°
	7½°	0.7	7.5	1.3	7.4	2.0	7.3	2.6	7.0	2.9	6.9	3.2	6.8	3.8	6.5	4.3	6.2	4.8	5.8	5.3	5.3	5.3	5.3	7½°
8°	0.7	8.0	1.4	7.9	2.1	7.7	2.8	7.5	3.1	7.4	3.4	7.3	4.0	6.9	4.6	6.6	5.2	6.2	5.6	5.6	5.6	5.6	8°	
9°	0.8	9.0	1.6	8.9	2.4	8.7	3.1	8.5	3.5	8.3	3.8	8.2	4.5	7.8	5.2	7.4	5.8	6.9	6.4	6.4	6.4	6.4	9°	
10°	0.9	10.0	1.8	9.9	2.6	9.7	3.5	9.4	3.9	9.3	4.3	9.1	5.1	8.7	5.8	8.2	6.5	7.7	7.1	7.1	7.1	7.1	10°	
11°	1.0	11.0	1.9	10.8	2.9	10.6	3.8	10.4	4.3	10.2	4.7	10.0	5.6	9.6	6.4	9.1	7.1	8.5	7.8	7.8	7.8	7.8	11°	
12°	1.1	12.0	2.1	11.8	3.2	11.6	4.2	11.3	4.7	11.1	5.2	10.9	6.1	10.4	7.0	9.9	7.8	9.3	8.6	8.6	8.6	8.6	12°	
13°	1.2	13.0	2.3	12.8	3.4	12.6	4.5	12.3	5.1	12.1	5.6	11.8	6.6	11.3	7.6	10.7	8.5	10.0	9.3	9.3	9.3	9.3	13°	
14°	1.2	14.0	2.5	13.8	3.7	13.5	4.9	13.2	5.5	13.0	6.0	12.7	7.1	12.2	8.1	11.5	9.1	10.8	10.0	10.0	10.0	10.0	14°	
15°	1.3	15.0	2.7	14.8	4.0	14.5	5.3	14.2	5.9	13.9	6.5	13.7	7.6	13.1	8.7	12.4	9.8	11.6	10.7	10.7	10.7	10.7	15°	
		Rad roll	Rad roll	Rad roll	Rad roll	Rad roll	Rad roll	Rad roll	Rad roll	Rad roll	Rad roll	Rad roll	Rad roll	Rad roll	Rad roll	Rad roll	Rad roll	Rad roll	Rad roll	Rad roll	Rad roll	Rad roll	Rad roll	
		85°	80°	75°	70°	67½°	65°	60°	55°	50°	45°													

VII. WHEEL R.P.M./S.F.P.M. CHART

Table of Grinding Wheel Speeds

To find the number of revolutions of the wheel spindle, having been given the surface or peripheral speed and the diameter of the wheel, divide the surface speed in feet per minute by the circumference (diameter x 3.14)

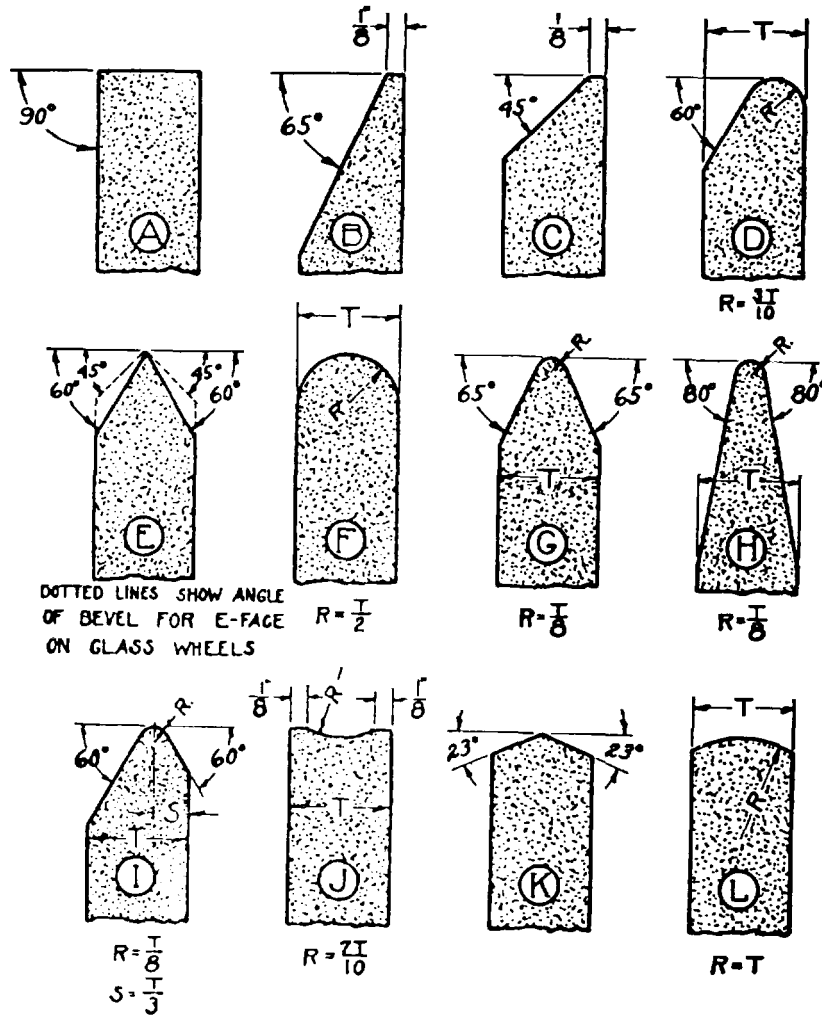
To find the surface speed of a wheel in feet per minute, multiply the circumference in feet by the revolutions per minute. in feet.

Diam. of Wheel in	Mm (Approx.)	Peripheral Speed in Feet per Minute					
		4000 Ft 1100 M	4600 Ft 1350 M	6000 Ft 1600 M	6600 Ft 1650 M	6000 Ft 1800 M	6600 Ft 1960 M
Revolutions per Minute							
1/4	6	61,116	68,756	76,392	84,032	91,672	99,212
3/8	9	40,744	46,594	50,928	56,021	61,115	66,141
1/2	13	30,558	34,378	38,196	42,016	45,836	49,656
5/8	16	24,446	27,502	30,557	33,615	36,669	39,685
3/4	19	20,372	22,918	25,464	28,011	30,557	33,071
7/8	22	17,462	21,826	21,826	24,009	26,192	28,346
1	25	15,279	17,189	19,098	21,008	22,918	24,828
2	50	7,639	8,594	9,549	10,504	11,459	12,414
3	75	5,093	5,729	6,366	7,003	7,639	8,276
4	100	3,820	4,297	4,775	5,252	5,729	6,207
5	125	3,056	3,438	3,820	4,202	4,584	4,966
6	150	2,546	2,865	3,183	3,501	3,820	4,138
7	175	2,183	2,455	2,728	3,001	3,274	3,547
8	200	1,910	2,148	2,387	2,626	2,865	3,103
10	250	1,528	1,719	1,910	2,101	2,292	2,483
12	305	1,273	1,432	1,591	1,751	1,910	2,069
14	355	1,091	1,228	1,364	1,500	1,637	1,773
16	405	955	1,074	1,194	1,313	1,432	1,552
18	455	849	955	1,061	1,167	1,273	1,379
20	505	764	859	955	1,050	1,146	1,241
22	560	694	781	868	955	1,042	1,128
24	610	637	716	796	875	955	1,034
26	660	588	661	734	808	881	955
28	710	546	614	682	750	818	887
30	760	509	573	637	700	764	828
32	810	477	537	597	656	716	776
34	860	449	505	562	618	674	730
36	910	424	477	530	583	637	690

VIII. STANDARD WHEEL SHAPES

Standard Shapes of Grinding Wheel Faces

When no face is specified, a straight "A" face wheel is furnished. The different faces which are regularly supplied are designated by letters as shown below:

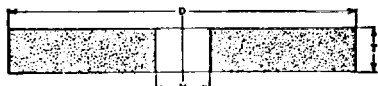


VIII. STANDARD WHEEL SHAPES

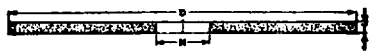
Key to Letter Dimensions

- A = Flat Spot of Beveled Wall.
- D = Diameter (Over All).
- E = Center or Back Thickness.
- F = Depth of Recess.
- G = Depth of Recess.
(See Type 5.)
- H = Arbor hole.
- J = Diameter of Fat or Small Diameter.

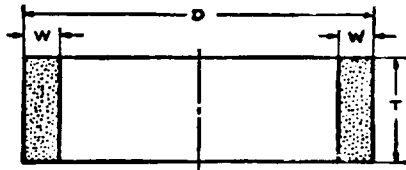
- K = Diameter of Flat Inside.
- M = Large Diameter of Bevel.
- P = Diameter of Recess.
- R = Radius.
- T = Thickness (Over All).
- U = Width of Face.
- V = Angle of Bevel.
- W = Thickness of Wall.



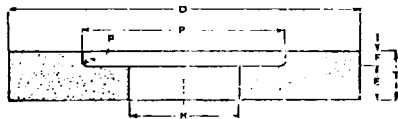
Type No. 1 Straight



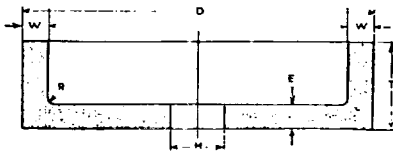
Type No. 1 Cut-off



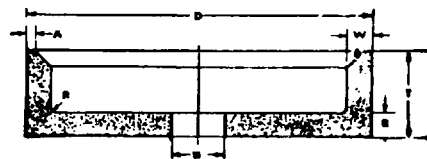
Type No. 2 Cylinder



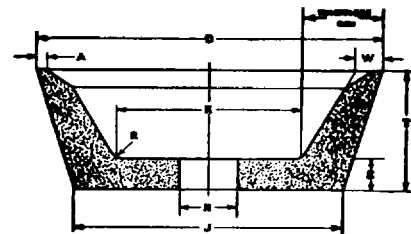
Type No. 5 Recessed One Side



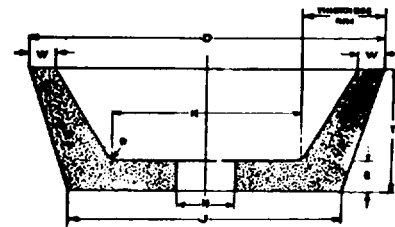
Type No. 6 Straight Cup



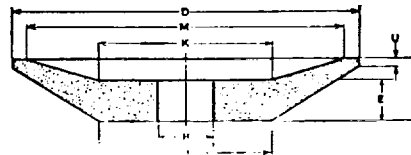
Type No. 6 Beveled Face



Type No. 11 Flaring Cup



Type No. 11 Beveled Face



Type No. 12 Dish

IX. METRIC AND DECIMAL EQUIVALENTS OF COMMON FRACTIONS

FRACTION OF INCH	DECIMAL OF INCH	MILIMETERS	FRACTION OF INCH	DECIMAL OF INCH	MILIMETERS
1/64	.015625	0.3969	33/64	.515625	13.0969
1/32	.03125	0.7938	17/32	.53125	13.4938
3/64	.046875	1.1906	35/64	.546875	13.8906
1/16	.0625	1.5875	9/16	.5625	14.2875
5/64	.078125	1.9844	37/64	.578125	14.6844
3/32	.09375	2.3812	19/32	.59375	15.0812
7/64	.109375	2.7781	39/64	.609375	15.4781
1/8	.125	3.1750	5/8	.625	15.8750
9/64	.140625	3.5719	41/64	.640625	16.2719
5/32	.15625	3.9688	21/32	.65625	1306688
11/64	.171875	4.3656	43/64	.671875	17.0656
3/16	.1875	4.7625	11/16	.6875	17.4625
13/64	.203125	5.1594	45/64	.703125	17.8594
7/32	.21875	5.5562	23/32	.71875	18.2562
15/64	.234375	5.9531	47/64	.734375	18.6531
1/4	.250	6.3500	3/4	.750	19.0500
17/64	.265625	6.7469	49/64	.765625	19.4469
9/32	.28125	7.1438	25/32	.78125	19.8438
19/64	.296875	7.5406	51/64	.796875	20.2406
5/16	.3125	7.9375	13/16	.8125	20.6375
21/64	.328125	8.3344	53/64	.828125	21.0344
11/32	.34375	8.7312	27/32	.843750	21.4312
23/64	.359375	9.1281	55/64	.859375	21.8281
3/8	.375	9.5250	7/8	.875	22.2250
25/64	.390625	9.9219	57/64	.890625	22.6219
13/32	.40625	10.3188	29/32	.90625	23.0188
27/64	.421875	10.7156	59/64	.921875	23.4156
7/16	.4375	11.1125	15/16	.9375	23.8125
29/64	.453125	11.5094	61/64	.953125	24.2094
15/32	.46875	11.9062	31/32	.96875	24.6062
31/64	.484375	12.3031	63/64	.984375	25.0031

Glossary of Terms

Abrasive: A substance used for abrading-grinding, polishing, lapping--such as the natural materials, corundum, emery, diamond, etc, and the manufactured or electric furnace materials, such as' aluminum oxide (AlV3), silicon carbide (SiC), boron carbide (B4C), and cubic boron nitride (BN).

Absolute Accuracy: Conformity in dimension to an exact standard or reference zero

Accurate: Made within the tolerances allowed.

Adapter: A tool holding device or sleeve for the fitting together of parts, shafts, shanks, etc, having different sizes or tapers. Widely used for milling-machine cutting tools to make them interchangeable for mills or tool maintenance machines.

Align: Adjusting to given points

Alloy: A mixture of two or more metals fused or melted together to form a new metal

Aluminum: A silvery-white, very lightweight metal seldom used in pure form. It is made from bauxite ore.

Aluminum Oxide: An abrasive made by fusing the mineral Bauxite (Al2O3).

Angle: The amount of opening or divergence between two straight lines that meet at a vertex or that intersect each other. Examples are cutter faces, clearance lands, or work faces relative to each other.

Annealing: The process of heating metal to a given temperature (the exact temperature and the period the temperature is held depends upon the composition of the metal being annealed) and cooling it slowly to remove stresses, to induce softness, to refine the structure, to alter physical properties.

Apprenticeship: A period of time agreed upon between employer and apprentice during which the employer promises to teach the apprentice the fundamentals of the trade. Usually a written agreement is signed by both parties.

Arbor: (grinding) The spindle shaft extension of the grinding machine on which the wheel is mounted.

Arbor: (workholding) A shaft or spindle for holding cutting tools

Arbor Hole: The hole in a grinding wheel or cutter sized to fit the machine arbor

Arc of Contact: That portion of the circumference of a grinding wheel touching the work being ground.

Area of Contact: The total area of the grinding surface of a grinding wheel in contact with the work being ground.

Assembly: A unit that contains the parts that make up a mechanism or a machine, such as the headstock assembly of a lathe. A machine may consist of several unit assemblies.

Assembly Drawing: A drawing which shows a complete machine or mechanism with all the parts in correct position and properly labeled or numbered
Axis: The center line, real or imaginary, passing through an object about which it could rotate. A point of reference.

Back Rake: The angle or slope ground on cutting tools to meet different conditions

*Instruction Manual**Glossary of Terms*

such as the hardness or toughness of metals being cut. On lathe cutting tools, the rake angles (top and side) are located on the top of the tool bit. The rake angle is positive if the face slopes downward from the point toward the shank and negative if the face slopes upward toward the shank.

Backing Off: A shop term meaning to put a relief or clearance land on a cutter back of the cutting edge or the primary relief land.

Backlash: Lost motion (play) in moving parts, such as thread in a nut or in the teeth of meshing gears.

Balance: (dynamic) A piece in static balance is in dynamic balance, if, upon rotating, there is no vibration nor "whip" action due to unequal distribution of its weight throughout its length.

Balance: (static) A grinding wheel is in static balance when, centered on a frictionless horizontal arbor, it remains at rest in any position.

Balancing: Testing for balance, adding or subtracting weight to put a piece into either static or dynamic balance.

Ball Bearing: An antifriction bearing having an inner race which fits on a shaft and an outer race which fits into a housing or support. Hardened steel balls are used between inner and outer races to reduce friction.

Bearing: Point of support. The part of a machine in which the spindle revolves.

Bed: One of the principal parts of a machine tool, having accurately machined ways or bearing surfaces for supporting and aligning other movable parts of the machine.

Bevel: The angle formed by a line or a surface that is not at right angles to another line or surface.

Blotter: A disc of compressible material, usually of blotting paper stock, used between a wheel and flanges when mounting.

Bond: The material in a grinding wheel which holds the abrasive grains together and supports them while they cut.

Bore: The inside diameter of a cylinder, or a hole for a shaft. Also, the operation of machining a circular hole in a metal workpiece.

Brass: An alloy of copper, tin, and lead.

Brazing: The joining of metals by the use of an alloy consisting of nonferrous metals having a melting point below that of the metals to be brazed. Brass and copper together with a suitable flux such as borax are often used.

Brinell Hardness Tester: A machine used for testing hardness by indentation of metals, except very hard ones like tool steels.

Brittleness: In some respects the opposite of toughness. The characteristics that cause metal to break easily.

Broach: A long tool on which the cutting teeth increase slightly in size with each succeeding tooth, and which is pushed or pulled through a hole or across a surface to form the desired shape and size.

Bronze: An alloy of copper and tin.

Brown and Sharpe Taper: A commonly used standard taper for shanks or arbors of milling machine tools and cutters.

*Instruction Manual**Glossary of Terms*

Burning (the work): A change in the work being ground caused by the heat of grinding, usually accompanied by a surface discoloration.

Burr: A turned over edge of metal resulting from punching a sheet and sometimes from grinding or cutting off operations.

Bushing: The material, usually lead, babbitt or aluminum, which sometimes serves as a lining for the hole in a grinding wheel.

Caliper: Instrument of measuring outside or inside diameters.

Cam: A plate or cylinder which transmits variable motion to a part of a machine by means of a follower.

Cap Screw: A finished screw, 1/8 Inch or larger, used for fastening two pieces together by passing the screw through a clearance hole in one part and screwing it into a tapped hole in the other. Heads may be hexagon, round, flat, fillister, or socket types.

Carbide Tools: Cutting tools with points of tungsten carbide, tantalum carbide, or other cemented carbide alloys. The carbide tips are brazed to steel shanks for strength and rigidity.

Carbon Steel: A broad term applied to tool steels other than high-speed or alloy steels.

Carborundum: A very hard artificial abrasive produced in an electric furnace. It is a compound of silicon and carbide. Also, the trade name for this abrasive Cast Iron: Iron which is cast in molds, is granular in form, and contains a high percentage of carbon in the form of graphite. It cannot be rolled, forged, or tempered.

Casting: A part made by pouring molten iron into a mold. Sand is commonly used for making the mold.

Center: A fixed point about which the radius of a circle or an arc moves

Center, Dead: A stationary center.

Center Hole Lapping: The cleaning or lapping of center holes with a bonded abrasive wheel cemented onto a steel spindle.

Centerless Grinding: Grinding the outside or inside diameter of a cylindrical piece which is supported on a work blade instead of being held between centers, and which is rotated by a so-called regulating wheel.

Center Line: A line used to indicate an axis of a symmetrical part. The center line consists of a series of long and short dashes.

Center Reamer: A countersink having a 60-degree included angle for sizing and smoothing center holes in workpieces to be turned or ground between centers. Centers: Conical steel pins of a grinding machine upon which the work is centered and rotated during grinding.

Ceramic Tools: A newer cutting-tool material made of aluminum oxide or silicon carbide held together by binders or additives of other materials.

Chamfer: To bevel or remove the sharp edge of a machined part. May be internal or external and is expressed by the length and angle.

*Instruction Manual**Glossary of Terms*

Chaser: A thread cutting tool that fits into a die head used on a turret lathe or screw machine. Usually a hardened steel plate with several teeth of the correct pitch cut into it Three or four chasers are used in a die head.

Chatter Marks: Surface imperfections on the work being ground usually caused by vibrations between the wheel and the work.

Chip Breaker: A groove ground into the top of a lathe, shaper, or planer tool bit to keep the chips short.

Chuck: A device for holding grinding wheels of special shape or the work piece being ground.

Clearance: Often used synonymously with clearance angle. The distance by which one object clears or misses another.

Clearance Angle: An angle ground on a cutting tool to permit it to cut metal

Climb Grinding: Work and grinding wheel traveling in the same direction at the point of contact.

Collet (Spring): Standard type of trisected hollow clamping or chucking device to hold work of a given diameter or form. Example standard 5C lathe collets. **Collet (wheel)** A type of arbor which holds the wheel and is attached to the end of a spindle shaft--usually by a taper lock.

Compound Slide: A principal part of a lathe, frequently called a compound rest, consisting of an upper and lower part dovetailed together. The lower part, or base, is graduated in degrees and can be swiveled to any angle for turning short tapers and angles. The upper slide carries the tool post and toolholder.

Concave Surface: A curved depression in the surface of an object

Concentric: Having a common center

Cone Wheel: A small wheel shaped like a bullet nose which is used for portable grinding.

Contour: The outline of an object.

Convex Surface: A rounded surface on an object

Coolant: The liquid or solution used to cool the work and to prevent it from rusting.

Corner Wear: The tendency of a grinding wheel to wear on a corner so that it does not grind sharp corners without fillets.

Critical Speed: Every spindle with a wheel or point mounted on it has a certain critical speed at which vibration due to deflection or whip tends to become excessive

Crossfeed: A transverse (across the axis) feed. In a grinder, the feed that operates at right angles to the axis of the work between centers or the main table.

Crush Truing (,Forming). The process of using steel rolls to true or form grinding wheels to a wide variety of shapes.

Cup Wheel: A grinding wheel shaped like a cup or bowl

Cutters: The part of a grinding wheel dresser that come, in contact with the wheel and does the cutting.

*Instruction Manual**Glossary of Terms*

Cutters (cutting tools): Usually of high-speed steel or carbide material

Cutting Angle: The angle measured between the cutting face of a tool and the surface of the material on which the tool operates.

Cutting-Off Wheel: A thin wheel, usually made with an organic bond, for cutting off.

Cutting Rate: The amount of material removed by a grinding wheel per unit of time

Cutting Surface: The surface or face of the wheel against which the material is ground.

Cylinder Wheel: A grinding wheel of similar characteristics to a straight wheel but with large hole size in proportion to its diameter and usually of several inches height.

Cylindrical Grinding: Grinding the outside surface or inside surface of a cylindrical (round) part mounted on centers, or held by a chuck or collet.

Deburring: Act of removing burrs from metal.

Diamond Tool: A diamond dresser.

Diamond Wheel: A grinding wheel in which the abrasive is natural or synthetic diamond.

Die: A tool used to cut external threads. Also, a tool used to impart a desired shape to a piece of metal.

Dish Wheel: A wheel shaped like a dish.

Dividing Head: An attachment for the milling machine for dividing or spacing holes, slots, gear teeth, and geometric shapes precisely. When geared to the table lead screw of a universal miller, helices (sometimes called spirals) can be cut. A grinder universal workhead which can be accurately indexed (rotated) by several methods is also termed "dividing head".

Dog (lathe or grinder): A device clamped onto work so that it can be machined between centers. A drive pin from the power head on the machine catches the dog during rotation, thus revolving the work.

Dog (trip): A projecting piece on the side of a machine tool worktable to trip the automatic feed mechanism for reverse travel

Dovetail Slide: A slide bearing consisting of two parts held in alignment by angular sides called dovetail angles and widely used in machine-tool construction. A gib on one side permits adjustment for smoothness of operation and wear.

Dressers: Tools used for truing and opening a grinding wheel.

Dressing: Removing wheel material to improve or alter its cutting action, usually by means of a diamond tool or abrasive dresser.

Eccentric: Not on a common center. A device that converts rotary motion into a reciprocating (back and forth) motion.

Emery: A natural abrasive of the aluminum oxide type.

End Mill: A milling cutter having a straight or tapered shank mounted into a drive holder. The cutting portion has teeth on the end as well as on the circumference.

Expansion Reamer: A type of hand or machine reamer in which the diameter may be slightly increased. An expansion chucking reamer which has become worn may be enlarged and then re-ground to the original size.

Face: That part of the wheel which does the grinding. Also, end cutting edges of a face mill.

Faceplate: A circular plate that fits to the headstock spindle and drives or carries work to be machined.

Feed, Cross (Surface grinding) The distance of horizontal feed of the wheel across the table.

Feed, Down (Surface grinding): The rate at which the abrasive wheel is fed into the work.

Feed, Down (Tool Grinding) Refers to the vertical feed on a tool grinder column, which when lowered, lowers the entire grinding head.

Feed, Index (Cylindrical grinding) Measurement indicated by the cross index of the machine. On most machines this measurement refers to the diameter of the work; on a few to the radius.

Feed Lines: A pattern on the work produced by grinding. The finer the finish, the finer and more evident are these lines. Some type of feed lines indicate incorrect grinding condition.

Finish: The surface quality or appearance, such as that produced by grinding or other machining operation, often measured by a profilometer measuring surface roughness.

Finishing: The final cuts taken with a grinding wheel to obtain accuracy and the surface desired.

Fixture: A device for holding work in a machine tool.

Flanges: The circular metal plates on a grinding machine, wheelshaft, arbor or collet, used to drive the grinding wheel by friction clamping(See wheel sleeves).

Flaring Cup Wheel: A cup wheel with the rim extending from the back at an angle so that the diameter at the outer edge is greater than at the back.

Flute: A straight or helical groove of angular or radial form machined in a cutting tool to provide cutting edges and to permit chips to escape and cutting fluids to reach the cutting edges.

Fluted Chucking Reamer: A machine reamer which has straight or helical flutes to provide cutting edges the entire length of the flutes. Intended for removing a small amount of metal (0.005 to 0015 inch) and for finishing a hole accurately and smoothly.

Fluting: Grinding the grooves of a twist drill, tap, or end mill.

Formed Cutters: Milling cutters for producing surfaces which have either a circular or irregular outline or shape. The operation is called form milling, and the cutters may be called form or formed cutters. The teeth of a formed cutter are relieved so that they can be ground without changing the outline or shape.

Forming Tool: A cutting tool used for forming regular or irregular shapes. The

cutting tool is ground to the shape desired and reproduces this shape on the work piece. Sometimes called a "slab forming tool" for use in lathes.

Gauge: A tool used for checking parts to determine whether they are made within specified limits.

Gauge Blocks: Precision gauge blocks are the accepted dimensional standards of industry. They are made with measuring surfaces which are plane, parallel, and a specified distance apart, then hardened, stabilized, and lapped to a very fine finish. Sets of gauge blocks make it possible to build up combinations that vary by only 25 millionths of an inch.

Gear Cutters: Accurately formed cutting tools of hardened steel having shaped teeth that cut the spaces between the teeth of a gear to the precise shape and size required.

Gib: A wedge-shaped strip that can be adjusted to maintain a proper fit of movable surface of a machine tool.

Glazing: The dulling of the cutting particles of a grinding wheel resulting in a decreased rate of cutting.

Grade: The strength of bonding of a grinding wheel, frequently referred to as its hardness.

Graduate: To divide into equal parts by engraving or cutting lines or graduations into the metal.

Grain (grit): Abrasive classified into predetermined sizes for use in polishing, in grinding wheels and in coated abrasive.

Grain Size: The size of the cutting particles of a grinding wheel or polishing abrasive

Grain Spacing: The relative position of the cutting particles in a grinding wheel

Gray Iron: The most popular type of cast-iron alloy used for machine castings. When broken, the cast iron appears dark and gray in color, thus its name. Relatively inexpensive, it has excellent melting, casting, and machining qualities.

Grinding: Removing material with a grinding wheel

Grinding Action: Refers to the cutting ability of, and the finish produced by, a grinding wheel.

Grinding Wheel: A cutting tool of circular shape made of abrasive grains bonded together.

Hardening: A heat-treating process of heating and cooling steel to increase its hardness and tensile strength, to reduce its ductility, and to obtain fine-grained structure.

Heat Treatment: Heating and cooling a solid metal or alloy in such a way as to obtain the desired conditions or properties. There are many different methods of heat-treating metals and each has a specific purpose.

Helical Angle: The angle which any portion of a helix or screw makes with a line drawn at right angles to its axis.

Helix: The path a point generates as it moves at a fixed rate of advance on the surface of a cylinder, such as screw threads or the flutes on a twist drill.

Hob: A special type gear cutter designed to cut gear teeth on a continuous basis.

Honing: A process used to produce the final fine surface finish on a part after all other operations. Honing permits a closer fit on critical parts. Abrasive blocks are forced against the work surface under very light spring pressure in a rotary motion and at the same time moved back and forth. The area is flooded with cutting fluid.

I.D.: Abbreviation for inside diameter.

I.D. Grinding: Abbreviation for internal grinding.

Independent Chuck: A chuck in which each jaw can be moved Independently of the other jaws.

Indexing: The term used to describe the correct spacing of holes, slots, etc, on the periphery of a cylindrical piece using a dividing or indexing head.

Indicator: A sensitive instrument capable of measuring slight variations when test- ing the trueness of work, machines or machine attachments.

Inserted Nut: Designating disc, segment, or cylinder wheels with nuts embedded in the back to facilitate mounting on the grinding machine.

Inserted Tooth Cutter: A milling cutter with teeth that can be replaced when they become damaged or worn rather than replacing the entire cutter.

Inspection: The process of measuring, testing, or gauging of workpieces to make certain each dimension is within the specified size shown on the blueprint.

Interlocking Cutters: Milling cutters consisting of two sections. Mating sections are similar to half-side or staggered-tooth cutters with uniform or alternate helical teeth so designed that the paths of teeth overlap when in proper assembly.

Internal Grinding: Grinding the inside surface (I D, inside diameter) of the hole In a workpiece.

Jo-Block: Precisely made steel or carbide blocks introduced by the Johnson Co, and used by Industry as a standard of measurement to millionths of an Inch They are made In a range of sizes and with a dimensional accuracy on the order of plus or minus .0000002 (two millionths) inch, with a flatness and parallelism of plus or minus .0000003 (three millionths) inch.

Key: A small piece of metal imbedded partially in the shaft and partially in the hub of a sleeve, gear, pulley, etc, to prevent its rotation on the shaft.

Keyseat: The slot or recessed groove, either In the shaft or gear, which is made to receive the key.

Keyway: The slot or recess In the shaft that holds the key

Keyway Cutter: A milling cutter of specified size or type, or other cutting tool, used to cut keyseats and keyways in the shaft or hole of parts to be fitted with keys
Land: The top surface the tooth or flute of cutting tools, such as taps, reamers, and milling cutters The land of a tap is the width of the threaded portion between the flutes.

Lapping: A finishing process typically employing loose abrasive grain, but now often including similar types of operation with bonded abrasive wheels or coated abrasives.

Lead Angle: The angle of the helix of a screw thread or worm thread. It is the measure of the inclination of a screw thread from a plane perpendicular to the axis of the screw.

Lead of Thread: On a single threaded screw, the distance the screw or nut advances in one complete revolution.

Left Hand Cutter: In lathe work, a cutting tool that cuts when fed from left to right or toward the tailstock. For milling cutters, when viewed from the spindle or shank end, the cutter would turn counterclockwise.

Left Hand Screw: One that screws into the mating part or advances when turned to the left or counterclockwise.

Lever: A simple machine for obtaining mechanical advantage. The lever consists of a rigid arm or bar pivoted or bearing on a point called the fulcrum and has a weight arm and a power arm.

Loading: Filling of the pores of the grinding wheel surface with the material being ground, usually resulting in a decrease in production and poor finish.

Lock Nut: A type of nut that is prevented from loosening under vibration. The locking action is accomplished by squeezing, gripping, or jamming against the bolt threads.

Machine Tool: The name given to that class of machines which, taken as a group, can reproduce themselves.

Mandrel: A hardened, tapered, or slightly tapered metal shaft, with the outside precisely concentric with the center holes, which is pressed into an accurate hole of a workpiece to support and revolve the part between centers.

Metal Slitting Saw: A thin milling cutter for slotting or cutting off stock in a milling machine.

Micro Inch: One millionth of an Inch

Micrometer: A precision, screw adjusted measuring instrument with which dimensions can be read in thousandths and ten-thousandths of an inch.

Micrometer Index Collar: A dial on the screw of a machine tool to indicate the movement of the screw or parts attached to the screw and usually graduated to read in thousandths of an inch.

Mill: To remove metal with a rotating cutter on a milling machine

Millimeter: One thousandths of a meter. Equivalent to 0.03937 Inches. One inch contains 25.4 millimeters.

Morse Taper: A standard taper of approximately $\frac{5}{8}$ inch per foot. Used on lathe centers, drill shanks, etc.

Mounted Points and Wheels: Small bonded abrasive shapes and wheels that are mounted on steel spindles.

Mounting: Putting a grinding wheel on the arbor or spindle of the machine.

Nut: A metal fastener of square, hexagon, or other shape, having an internal thread which screws onto a bolt, stud, or arbor.

O.D.: An abbreviation for outside diameter.

O.D. Grinding: Abbreviation for cylindrical grinding

Oilstone: A natural or manufactured abrasive stone impregnated with oil and used for sharpening keen edge tools.

Operating Speed: The speed of revolution of a grinding wheel expressed in either revolutions per minute or surface feet per minute.

Organic Bond: A bond made of organic materials such as the synthetic resins, rubber or shellac.

Parallel: Two lines in the same plane equidistant from each other and never meeting no matter how far extended.

Peripheral Speed: The speed at which any point or particle on the face of the wheel is traveling when the wheel is revolved, expressed in surface feet per minute (s f p m). Multiply the circumference in feet by the wheel revolutions per minute.

Periphery: The line bounding a rounded surface - the circumference of a wheel or cutter.

Perpendicular: A line or surface which meets another line or surface at right angles (90 degrees).

Pinion: The smaller of two mating gears

Plain Milling Cutter: A milling cutter that has cutting teeth on the circumference surface only.

Plug Gauge: A gauge on which the outside measuring surfaces are designed to test the special dimensions of holes. May be straight or tapered, plain or threaded, and of any cross-sectional shape.

Profilometer: An instrument for measuring the degree of surface roughness in micro inches, and often stated in R M S --root mean square values.

Pulley: A wheel having a plain or V-groove rim over which a belt runs for the transmission of power from one shaft to another.

Rack: A flat strip with teeth designed to mesh with teeth on a gear. Used to change rotary, motion to reciprocating motion.

Radial: Arranged outward from the center as the spokes of a wheel.

Radius: The distance from the center of a circle to the circumference which is equal to one-half the diameter.

Radius Cutter: A side or end milling cutter which has the edges of the teeth ground to a specified radius so it will reproduce the radius on the workpiece.

Rake Angle: For milling cutters, the angle between the cutting edge (face) and the work. With the cutting edge located along the radius line of the cutter, the tool has a zero rake. When the cutting edge (face) is ahead of the radius of the cutter, the rake is positive. If the cutting edge (face) is behind the radius of the cutter, the rake is negative. For single point lathe tools, the slope of the tool face toward the tool base from the cutting edge in the direction of the chip flow. It is the combination of the back-rake and side-rake angles which varies with the setting of the tool and the feed and depth of cut. For twist drills, the angle the flute or helix makes with the axis.

Reamer: A cutting tool used to produce a smooth, accurate hole by removing a small amount of metal from a drilled hole.

Recessed Wheels: Grinding Wheels made with a depression in one side or both sides to fit special types of flanges or sleeves provided with certain grinding machines.

Reinforced Wheel: A grinding wheel in which some type of mechanical addition has been added as an integral part of the wheel to increase its strength.

Relief: The offset surface immediately back of the cutting edge or face to provide clearance on a cutting tool to allow for the non-cutting portion of the cutter to clear the work. Some manuals call the first clearance land back of the cutting edge the relief, and the second land the clearance. The terms of 'relief' and 'clearance' are used synonymously in this manual, the latter being used for both primary and secondary lands, depending on the context.

Relieving: To remove some of the metal behind the cutting edge of a tool to provide clearance, as for taps and milling cutters. Also called backing off.

Resinoid Bond: A bonding material described commercially as synthetic resin.

Rest: That part of a grinding wheel stand which is used to support the work, dresser or truing tool when applied to the grinding wheel.

Right Angle: An angle of 90 degrees

Right-Cut Tool: A single-point lathe tool which, when viewed from the point end of the tool with the face up, has the cutting edge on the right side. When used in the lathe, the cutting edge is on the left side and cuts when fed from right to left.

Right-Hand Cutter: A term used to describe both rotation and helix of milling cutters. A cutter that rotates clockwise when viewed from the spindle end is said to have right-hand motion. A cutter has a right-hand helix when the flutes slant downward to the right when viewed from the front, or twist clockwise when viewed from the end.

Right-Hand Thread: A screw thread which advances into the mating part when turned clockwise or to the right.

Rockwell Hardness Tester: A machine used for testing hardness by the indentation method.

Rose Reamer: A machine reamer designed so that all the cutting is done on the beveled ends of the teeth instead of on the sides.

Rough Grinding: The first grinding operation for reducing stock rapidly without regard to the finish the wheel leaves.

R.P.M. Revolutions per minute.

Rubber Bond: A bonding material, the principal constituent of which is natural rubber or synthetic rubber.

Run-out: Peripheral or lateral (axial) distance variation from a fixed axis center or radial plane of a circular object.

Safety Flanges: Special type of flanges designed to hold together the broken parts of a wheel in case of breakage, thus protecting workmen.

Saucer Wheel: A shallow, saucer-like wheel.

- Saw Gummer:** A grinding wheel used for gumming or sharpening saws
- Scleroscope:** An instrument for determining the relative hardness of materials by a drop and rebound method.
- Scratches:** Marks left on a ground surface caused by a dirty coolant or a grinding wheel unsuited for the operation.
- Set Screw:** Usually a hardened steel screw having either no head or a square head and with various designs of points or ends to lock or tighten adjustable machine parts in position on a shaft.
- Set-up:** The term used to describe the positioning of the workpiece, attachments and cutting tools on a machine tool.
- S.F.P.M.:** Surface feet per minute. See "Peripheral Speed" Multiply the circumference in feet by the wheel revolutions per minute.
- Shank:** The noncutting end of a tool which fits into the holding device for driving, as the taper shank on a drill.
- Shellac Bond:** A bonding material, the principal constituent of which is shellac.
- Shell Reamer:** A reamer which has a slightly tapered hole to fit on the end of an arbor or shank for holding and driving in a machine. One arbor can be used for several reamer sizes. Should the reamer become damaged, only the reamer end need be replaced.
- Side-Clearance Angle:** An obsolete term which refers to the amount of angle ground on the sides of a single-point cutting tool. It is replaced by the new term side-relief angle.
- Side-Milling Cutters:** Cutters which have cutting teeth on one or both sides as
- Side-Relief Angle:** On a single-point cutting tool, the angle between the portion of the flank immediately below the cutting edge and a line drawn through this cutting edge perpendicular to the base. Also, the angle of relief on the sides of milling cutters.
- Silicone Carbide:** An abrasive made from coke and silica sand (SiC).
- Sine of an Angle:** In a right triangle, the ratio of the side opposite to the side adjacent.
- Sine Bar:** A flat piece of metal accurately ground parallel and square to which is attached two hardened and ground steel plugs having the same diameter and usually spaced either 5 or 10 inches apart. The sine bar is used to measure angles accurately. Also, the sine bar represents the hypotenuse of a right triangle.
- Single-Point Tools:** Cutting tools for use in a lathe, planer, or shaper. Single-point tools have one face and one continuous cutting edge which produce the machined surface.
- Slabbing Cutter:** A wide plain milling cutter designed for heavy roughing cuts.
- Sleeve:** A round piece of metal having a straight or tapered hole which fits over or into another piece to adapt parts to fit, as a taper sleeve for a lathe center.
- Slitting Saw:** A thin milling cutter of the plain type used for slotting or cutting off material in the milling machine.

Slotting Wheel: A thin grinding wheel, usually organic bonded, used for cutting slots or grooves in the work piece.

Spanner Wrench: A type of wrench having a hook or equipped with pins for tightening or loosening threaded circular collars which have either slots or holes to receive the hook or pins on the wrench.

Spindle (grinding): Often used synonymously with "quill", the term usually refers to a precision bearing mounted shaft inside a housing with end caps which hold or tighten and compress the bearings and shaft in a fixed position.

Spindle (workhead): Precision bearing mounted hollow steel sleeve with internal taper inside a housing, used to hold workholding arbors by means of an internal taperlock.

Spring Collets: A type of draw-in collet made of hardened steel and having three slots or saw cuts which permit the collet to be closed tightly upon the workpiece when drawn back against a tapered sleeve by the draw bar or tube.

Stagger-Tooth Cutters: Side-milling cutters in which the teeth have alternating helix and the "drag" ends are eliminated to provide more chip clearance.

Standard Tapers: Any of the numerous tapers specified in the American Standard system of tapers which include the self-holding tapers.

Steady Rest: A support attached to the ways of a lathe or grinding machine for turning long workpieces. The steady rest is used to prevent slender work from springing away from the cutting tool or wheel, or to permit machining operations to be performed on the end of the workpiece. Sometimes called a center rest.

Stops: Devices attached to the movable parts of a machine tool, such as a grinder table, to limit the amount of travel. When set and clamped in position, they assure the uniformity of each workpiece. Projections on the side of the worktable may also engage automatic power feed, and are known as a 'dog'.

Straight Wheel: A grinding wheel of any dimension which has straight sides, a straight face, and a straight or tapered arbor hole, and is not recessed, grooved, dovetailed, beveled or otherwise changed from a wheel with plain parallel sides.

Structure: A general term referring to the proportion and arrangement of abrasive and bond in an abrasive product.

Stub: That portion of a grinding wheel remaining after it has been worn down to the discarding diameter.

Surface Grinding: Abrasive machining which grinds flat surfaces on work pieces having sides parallel or at angles to each other.

Surface Roughness Scale: A series of small plates visualizing the degree of roughness for a particular surface. They establish a standard permitting a machinist or an inspector to compare specified finishes visually and by feel.

Table: That part of the grinding machine which directly or indirectly supports the work being ground.

Table Traverse: The length of reciprocating movement of the table of a grinding machine.

Tailstock: The part of a machine tool which holds one end of a work piece with

Instruction Manual**Glossary of Terms**

centers. A principal part of the engine lathe used for supporting the ends of work- pieces by means of a center point held in the spindle. May be moved along the ways and clamped in different positions and offset from the true axis of the lathe for turning tapers.

Tangent: A line that touches the circumference of a circle at one point only

Tap: A hardened and tempered steel tool for cutting internal threads which has flutes lengthwise to provide cutting edges for the threads and a square at the end of the shank for turning the tap with a wrench.

Taper: A piece of work which increases or decreases uniformly in diameter or size and assumes a conical or wedge shape.

Tapered Wheel: A grinding wheel shaped similarly to a straight wheel but having a taper from the but of the wheel to the face and thus being thicker at the hub than at the face.

Taper Per Foot: A means of specifying the amount or rate that a taper increases or decreases for each foot of length, usually stated in inches per foot.

Taper Reamer: A fluted reamer which has the cutting ends made to the standard taper it is designed to cut. The taper reamer is used either for roughing or finish- 4ng taper holes to size by hand or power according to the design of the reamer. Roughing reamers have notched teeth to relieve the load on the teeth.

Taper Taps: One of the three taps in a set of hand taps. The end threads are tapered or chamfered back for a length of 8 to 10 threads for easy starting.

T-Bolt: A threaded bolt having a square or rectangular end which fits into the T-slot of a machine table for clamping workpieces.

Teeth: Molded organic bonded abrasive segment for insertion in the periphery of a steel disc. Also, cutting segments or flutes of a milling cutter.

Temper: The heat treatment of a material to develop required qualities.

Tensile Strength: The strength of a material when tested in tension usually given in pounds per square inch.

Tolerance: The permissible deviation from a basic dimension

Tool Bit: A piece of high-speed steel, usually square in shape and of suitable length, which may be ground to various shapes and forms for single-point cutting tools that are used in lathes, shapers, and planers for cutting metal.

Toolroom: Area or department where tools, jigs, fixtures and dies are manufactured

Truing: A grinding wheel is trued in order to restore its cutting face to running truth so that it will produce perfectly round (or flat) and smooth work; or to alter the cutting face for grinding special contours.

Universal Chuck: A chuck on which all laws move simultaneously at a uniform rate to center round or hexagonal stock automatically.

Universal Grinding Machine: A machine such as the K. O. Lee Universal Tool and Cutter Grinder on which cylindrical, internal and surface grinding can be done- usually used for tool room work. It consists of a swivel table, headstock, tailstock, and a wheelhead that can be rotated 360 degrees on its base and raised or lowered. It is also used for tool and cutter grinding with the addition of various fixtures.

*Instruction Manual**Glossary of Terms*

Universal Vise: A work-holding device usually used on the milling machine which has either two or three swivel settings so that workpieces may be set at any desired angle, including compound angles. Also, called a toolmaker's vise. The K. O Lee B989 fixture is an adaptation of this principle for tool grinding machines.

Vitrified Bond: A bonding material of which the chief constituent is clay

Vitrified Wheel: A grinding wheel made with a vitrified ceramic bond

V-Ways: The raised portion on machine tool beds that act as bearing surfaces and guide and align the movable portion of the machine that rides on them. They are shaped like an inverted V.

Washers: Circular metal rings or discs or various designs having a hole through the center and placed between a bolthead or a nut and the workpiece. A washer is used to lock a nut in place and to provide a seat that distributes the pressure over a greater area for holding parts together.

Ways: The flat or V-shaped bearing surfaces on a machine that aligns and guides the movable part of the machine that rides on them.

Wheel Dresser: A device to true the face of a grinding wheel

Wheel Sleeves: A form of flange used on precision grinding machines where the wheel hole is larger than the machine arbor. Usually the sleeve is so designed that the wheel and sleeve are assembled as one unit.

Wheel Traverse: The rate of movement of the wheel across the work

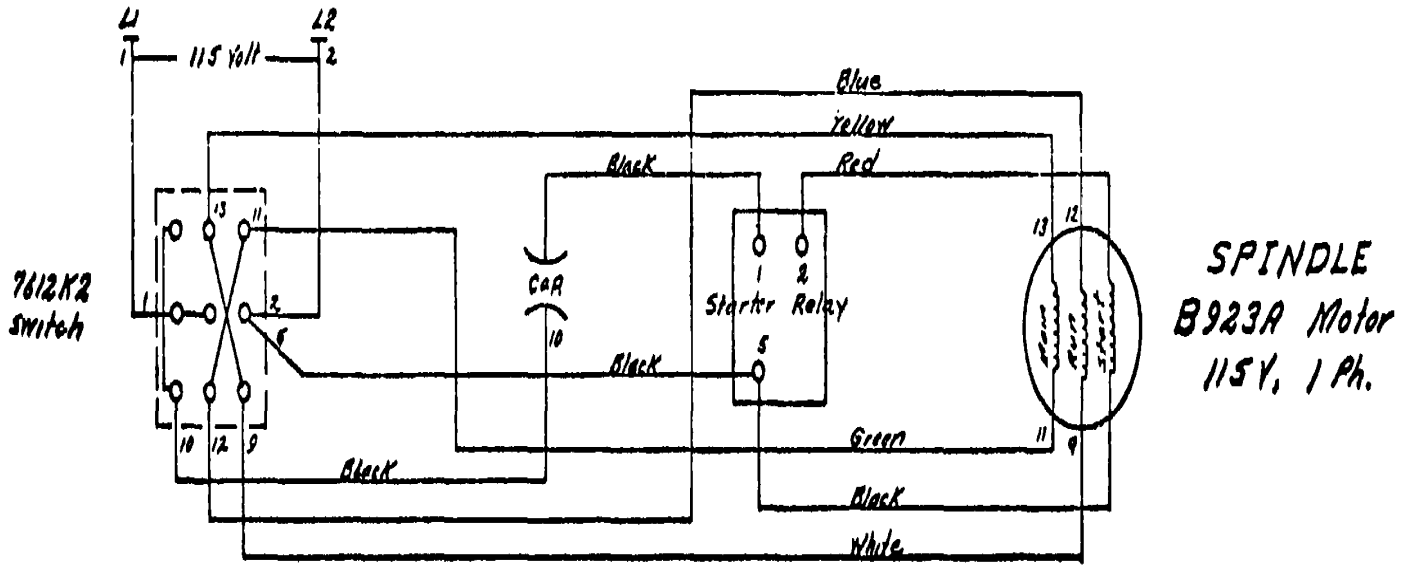
Woodruff Key: A flat, semicircular piece of metal used as a key in a special circular keyseat slot cut in a shaft to drive a gear, pulley, or other part.

Work: Term used to designate the material being machined,

Work Speed: In cylindrical, centerless and internal grinding, the rate at which the work revolves, measured in either r p m or s. f. p m.; in surface grinding, the rate of table traverse measured in feet per minute.

Worm: A threaded cylinder or shaft which meshes with and drives a worm gear, the thread being especially designed to mate with the teeth in the worm gear.

Worm Gears: Gears with teeth cut on an angle to be driven by a worm. The teeth are usually cut out with a hob to fit the worm.



By Order of the Secretary of the Army.

E. C. MEYER
General, United States Army
Chief of Staff

Official:

ROBERT M. JOYCE
Brigadier General, United States Army
The Adjutant General

RECOMMENDED CHANGES TO EQUIPMENT TECHNICAL PUBLICATIONS



THEN... JOT DOWN THE DOPE ABOUT IT ON THIS FORM, CAREFULLY TEAR IT OUT, FOLD IT AND DROP IT IN THE MAIL!

SOMETHING WRONG WITH THIS PUBLICATION?

FROM: (PRINT YOUR UNIT'S COMPLETE ADDRESS)

DATE SENT

PUBLICATION NUMBER

TM 11-5825-270-10

PUBLICATION DATE

23 Jul 81

PUBLICATION TITLE

Radio Frequency R-2176/FRN

BE EXACT... PIN-POINT WHERE IT IS

PAGE NO.

PARA-GRAPH

FIGURE NO.

TABLE NO.

IN THIS SPACE TELL WHAT IS WRONG AND WHAT SHOULD BE DONE ABOUT IT:

TEAR ALONG PERFORATED LINE

PRINTED NAME, GRADE OR TITLE, AND TELEPHONE NUMBER

SIGN HERE:

DA FORM 2028-2
1 JUL 79

PREVIOUS EDITIONS ARE OBSOLETE.

P.S.—IF YOUR OUTFIT WANTS TO KNOW ABOUT YOUR RECOMMENDATION MAKE A CARBON COPY OF THIS AND GIVE IT TO YOUR HEADQUARTERS.

